

斗提机螺栓



4B GROUP



散装物料输送处理领域领先
核心机械、电子部件供应商

品质 安全 创新 价值

BETTER BY DESIGN

斗提机螺栓

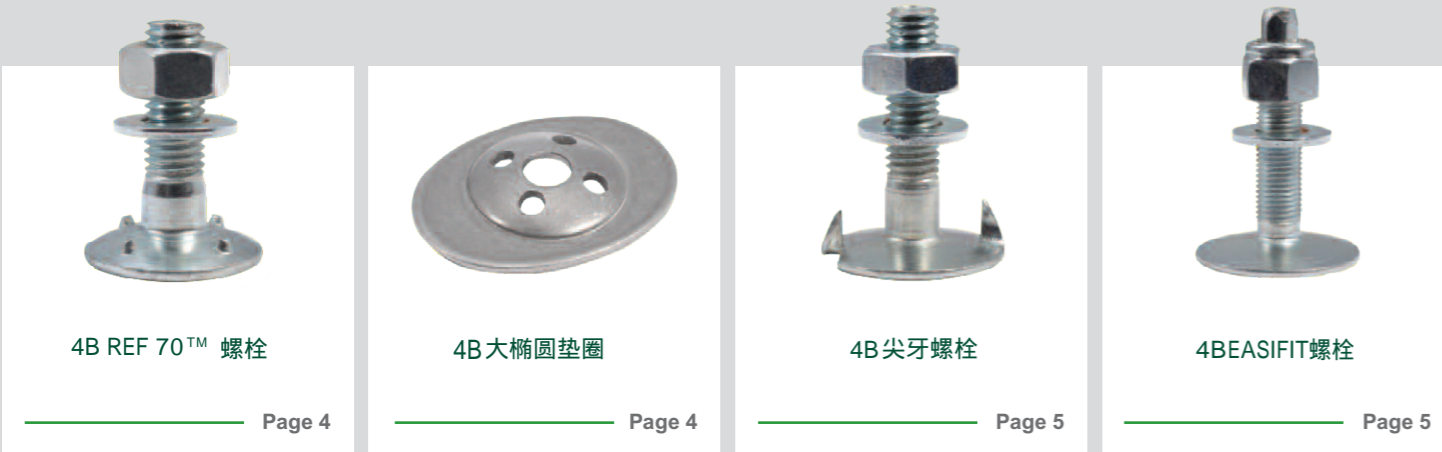
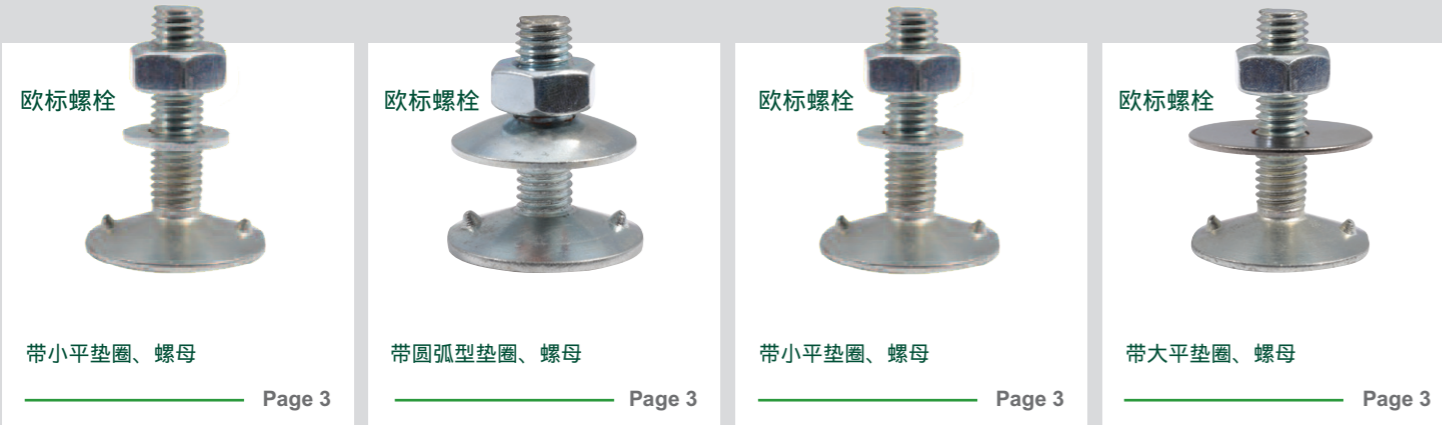

获取免费的工程技术咨询联系 4B 或访问4B官方网站: www.go4b.com

EURO BOLT 欧标螺栓

4B EURO BOLT



碳钢或不锈钢螺栓

- > 按DIN15237标准制造
- > ISO等级5.8级(大于DIN15237)
- > 大螺栓头直径
- > 全螺纹设计
- > 可提供镀锌、本色或不锈钢型号

> 包装选择:

- 盒装, 包含螺栓、六角螺母以及圆弧形垫圈
 - 仅螺栓, 成袋散装
- 螺栓额定扭矩取决于漏斗和皮带规格



固定带凹陷孔的钢制漏斗, 应加大大圆弧垫圈



固定带平孔的钢制漏斗, 应采用小平垫圈



固定塑料漏斗, 应采用大平垫圈

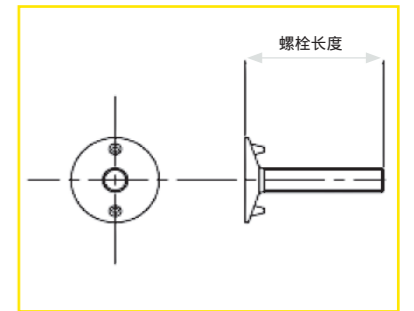

螺栓、六角螺母、小平垫圈 (每盒100只装)-重量/100套

螺栓规格	螺栓头 Ø (mm)	最大扭矩 (Nm)	螺栓长度									
			20 (mm)	22 (mm)	25 (mm)	30 (mm)	35 (mm)	40 (mm)	45 (mm)	50 (mm)	60 (mm)	70 (mm)
M6	21	8	1.28	-	1.38	1.50	-	-	-	-	-	-
M7	23	13	1.82	1.94	2.10	2.16	2.22	-	-	-	-	-
M8	28	20	2.98	2.00	3.00	3.02	3.37	3.72	3.88	3.94	-	-
M10	35	36	-	-	5.42	5.43	5.44	5.84	6.02	6.18	-	-
M12 ¹⁾	42	65	-	-	-	-	-	9.24	-	4.96*	5.36*	5.60*

1) 没有不锈钢产品供应 / * 50 只装重量(Kg)

仅螺栓(成袋散装) - 重量 Kg/包

螺栓规格	螺栓长度										Qty
	20 (mm)	22 (mm)	25 (mm)	30 (mm)	35 (mm)	40 (mm)	45 (mm)	50 (mm)	60 (mm)	70 (mm)	
M6	19.4	-	20.8	21.4	-	-	-	-	-	-	2000
M7	20.1	21.3	22	24.2	17.5*	-	-	-	-	-	1500
M8	10.1	11.1	11.3	12.3	13	13.7	14.3	14.9	-	-	500
M10	-	-	18.8	20	21	22.3	23.7	12.6**	-	-	500
M12 ¹⁾	-	-	-	-	15.9	16.7	17.7	18.7	20.8	23.2	250

1) 没有不锈钢产品供应 / * 每盒100只 / ** 每盒250只

4B REF 70™ 螺栓



碳钢或不锈钢螺栓

- ISO等级5.8级（高于DIN15237）
- 螺栓头斜锥面带有4个凸点防止在紧固时发生旋转
- 标准配置包含六角螺母和小平垫圈
- 英制螺纹和公制螺纹可选
- 可镀锌（特殊根据特殊要求可提供本色或）
- 螺栓锁紧扭矩取决于漏斗及皮带规格

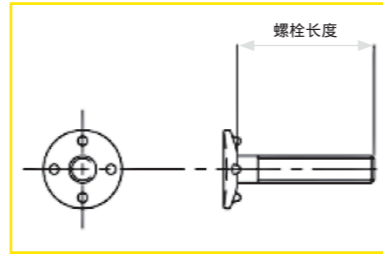

螺栓规格	螺栓头 Ø (mm)	最大扭矩 (Nm)	螺栓长度								
			1/2" 12 (mm)	3/4" 20 (mm)	1" 25 (mm)	1 1/4" 30 (mm)	1 1/2" 40 (mm)	1 3/4" 45 (mm)	2" 50 (mm)	2 1/4" 55 (mm)	2 1/2" 65 (mm)
1/4" BSW M6	17	5	1.04	1.18	1.24	1.48	1.56	-	-	-	-
5/16" BSW M8	23	10	-	2.08	2.38*	2.54*	2.90*	-	3.24	-	-
3/8" BSW M10	27	18	-	-	3.94	4.44*	4.80*	5.08*	5.36*	5.50	5.72
1/2" BSW M12	35	42	-	-	-	7.44	7.78	8.12	8.44	9.08	-

* 有不锈钢螺栓供应

4B 大椭圆垫片



有镀锌产品和不锈钢产品供应

- 在重型应用环境中与Ref 70™ 螺栓配合使用
- 可分布在螺栓头上的4个凸点，能有效增加螺栓抓握力
- 要完美容纳大椭圆垫片皮带必须具有足够的厚度和/或应在漏斗上设计凹陷孔
- 不推荐用在皮带轮直径小于500mm的斗提皮带上
- 将椭圆长轴方向与皮带宽度方向保持一致

垫片规格	Ø	(mm)	Kg/100
LOW1	1/4" M6	33/45	1.44
LOW2	5/16" M8*	37/50	2.22
LOW3	3/8" M10*	45/57	2.90
LOW4	1/2" M12*	53/63	3.94

* 全部为不锈钢产品

4B EASIFIT BOLTS 螺栓



有不锈钢产品可选

- 带小垫片和尼龙自紧螺母
- 螺栓头被加工成方形，便于使用特殊工具，可防止上紧螺母或拆卸螺母时螺栓的转动，提高工作效率
- 提高锁紧或拆卸螺母的效率
- 提高斗提机的安全等级
- 相比其他普通螺栓对皮带的损伤更小
- UNF 细牙设计，更牢靠
- 锁紧扭矩以螺栓尺寸而定

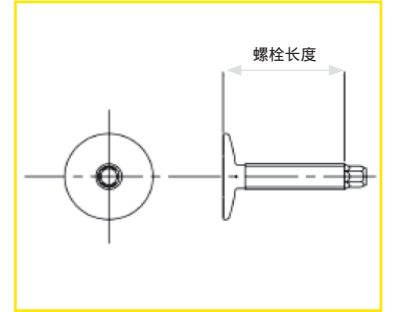

螺栓规格	螺栓头 Ø (mm)	最大扭矩 (Nm)	螺栓长度 (从螺纹量到螺栓头底部)					
			3/4"	1"	1 1/4"	1 1/2"	1 3/4"	2"
1/4" UNF	25	12	1.82	1.88*	2.04	-	-	-
5/16" UNF	30	25	2.84*	3.02*	3.24	3.48	3.68	-
3/8" UNF	32	46	-	4.56	4.70*	5.10*	5.50	5.90

标准产品为镀锌，有碳钢本色或不锈钢可选

安装方头螺栓需要特殊的棘轮扳手。棘轮锁住螺栓的方头，防止上紧螺栓时的转动。有手动扳手和气动棘轮扳手可选。



4B FANG BOLTS 尖牙螺栓



有不锈钢产品可选

- 独特的设计“尖牙”咬入皮带，上紧螺母时防止螺栓转动
- 方便上紧和拆卸螺栓螺母
- 大直径螺栓头抗拉穿能力更强
- 螺栓头更扁平 - 贴合皮带更紧密，有效防止螺栓脱落
- 凹陷孔、非凹陷孔都适用
- CC-S 漏斗的理想螺栓
- 锁紧扭矩以螺栓尺寸而定

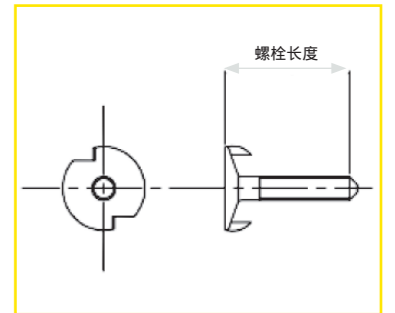

螺栓规格	螺栓头 Ø (mm)	最大扭矩 (Nm)	螺栓长度 从螺纹量到螺栓头底部						
			20 (mm)	25 (mm)	30 (mm)	35 (mm)	40 (mm)	45 (mm)	80 (mm)
M6	25	11	1.56	1.82	-	-	-	-	-
M8	30	27	-	2.76	2.02	-	3.24	-	-
M10	27	47	-	-	4.90	5.12	5.34	5.56	-

标准产品为镀锌，有碳钢本色或不锈钢可选

公制尼龙自紧螺母 (DIN 985)

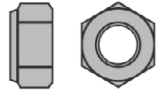

Ref.	Ø	Kg/100
NY06	M6	0.15
NY07	M7	0.20
NY08	M8	0.48
NY10	M10	1.10
NY12	M12	1.50

BSW 英制螺纹尼龙自紧螺母 (P-TYPE)

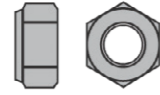

Ref.	Ø	Kg/100
NY1	1/4"	0.44
NY2	5/16"	0.76
NY3	3/8"	0.97
NY4	1/2"	2.72

半高六角螺母 (HALF NUTS)



Ref.	Ø	Kg/100
HN2	5/16" BSW	0.34
HN3	3/8" BSW	0.54
HNM8	M8	0.48
HNM10	M10	0.90

EASIFIT 手工工具



Ref.	Ø
EFHT1	1/4"
EFHT2	5/16"
EFHT3	3/8"

薄型圆弧垫圈 (非DIN表) 只有304不锈钢供应

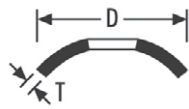

Ref.	Ø	D	T	Kg/100
DW06 304S	M6	25	1.0	0.45
DW08 304S	M8	32	1.0	0.65
DW10 304S	M10	40	1.0	1.50

不锈钢大平垫/用于维修

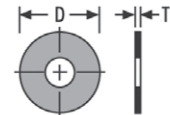

Ref.	Ø	D	T	Kg/100
FW1S	M6	25	1.5	0.50
FW2S	M8	30	1.5	0.70
FW3S	M10	30	1.5	0.92

DIN15237中碳钢圆弧垫片

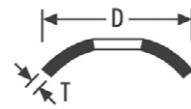

Ref.	Ø	D	T	Kg/100
DW06	M6/M7	25	1.5	0.60
DW08	M8	32	1.5	0.90
DW10	M10	40	2.0	1.80
DW12	M12	50	2.0	2.70

EASIFIT 气动工具



Ref.	Ø
EFAT1	1/4"
EFAT2	5/16"
EFAT3	3/8"
EFAT4	1/2"

橡胶垫圈

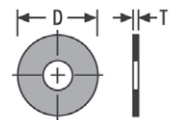

Ref.	Ø	D	T	Kg/100
RW2	M8	25	5	0.18
RW3	M10	30	5	0.28

中碳钢大平垫,用于维修

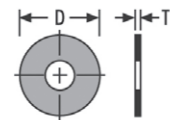

Ref.	Ø	D	T	Kg/100
FW1	M6	25	1.5	0.35
FW2	M8	25	1.5	0.81
FW3	M10	30	1.5	0.79
FW4	M12	38	1.5	1.24

弹簧垫圈



Ref.	Ø	Kg/100
SP1	M8 / 5/16"	0.02
SP2	M10 / 3/8"	0.04

防震垫圈

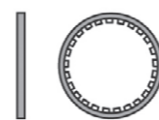

Ref.	Ø	Kg/100
SHM1	M6	0.02
SHM2	M8	0.03
SHM3	M10	0.04

4B GRIPWELL 轻型皮带扣

- 适用于皮带强度不超过500 kN/m以及厚度不超过7.0mm的轻型皮带
- 压条之间形成咬合区域
- 标准皮带扣宽度150mm, 300mm宽皮带用2个标准皮带扣

皮带头最少露出25mm

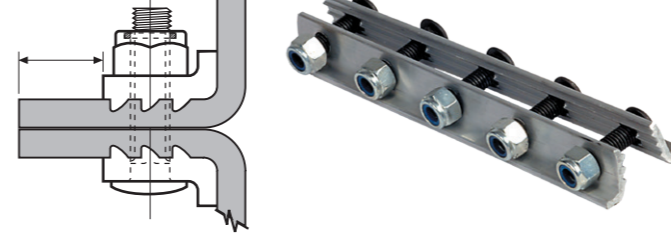

Belt Width (in)	Belt Width (mm)	Actual Length (mm)	Bolt Holes (mm)	Bolt Ø (mm)	Hole Centres (mm)
2	50	45	2	8	25
2 1/2	65	57	2	8	33
3	75	70	2	8	43
3 1/2	90	83	3	8	2x28
4	100	96	3	8	2x33
4 1/2	115	109	3	8	2x42
5	125	122	4	8	3x32
5 1/2	140	134	4	8	3x36
6	150	147	4	8	3x40
6 1/2	165	160	5	8	4x33
7	175	172	5	8	4x36
8	200	198	6	8	5x34
9	225	223	6	8	5x40
10	250	248	7	8	6x37
11	275	273	7	8	6x41
12	300	299	8	8	7x39

4B SUPERGRIP 重型皮带扣

- 模块化, 每个模块宽 50mm
- 4 种类型, 最大皮带强度1250 kN/m, 无皮带厚度限制
- 对分的两块压块, 用高强度螺栓和尼龙自锁螺母锁紧即可
- 标准尼龙自锁螺母, 可以用于 80° C温度, 高于80°C温度要使用Philidas 防松螺母
- 有不锈钢产品可选

在宽度为150至195mm的皮带上使用3个Supergrip的接头, 皮带头最小露出25mm

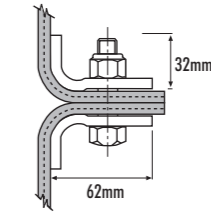
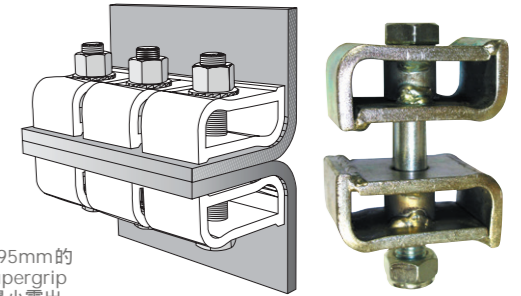

- SUPERGRIP NO.1**
- 皮带强度 - 最大500kN/m
 - 单件质量 - 0.5Kgs
 - M14 螺栓

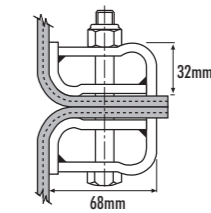

- SUPERGRIP NO.2**
- 皮带强度 - 最大630kN/m
 - 单件质量 - 0.8Kgs
 - M14 螺栓

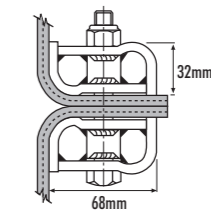

- SUPERGRIP NO.3**
- 皮带强度 - 最大800kN/m
 - 单件质量 - 0.85Kgs
 - M14 螺栓

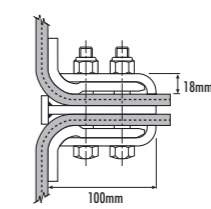

- SUPERGRIP NO.4**
- 皮带强度 - 最大1000 & 1250kN/m
 - 单件质量 - 1.83Kgs
 - M16 螺栓

强度超过 1250kN/m的皮带可以定制皮带扣, 联系4B技术部门

获取免费的工程技术咨询联系 4B 或访问4B官方网站: www.go4b.com



4B 其他产品型录:

- ▶ 电子产品
- ▶ 斗提皮带及紧固件
- ▶ 斗提机畚斗
- ▶ 自由锻链传动产品

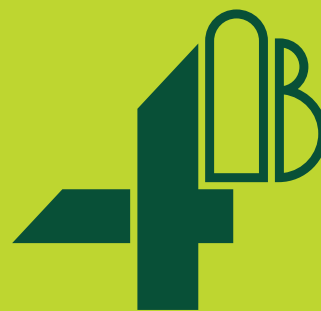

www.go4b.com



BETTER BY DESIGN



4B Braime Components

Headquarters
Hunslet Road
Leeds, LS10 1JZ, UK
Tel: +44 (0) 113 246 1800
Email: 4b-uk@go4b.com



4B Components

625 Erie Avenue
Morton
IL 61550, USA
Tel: 309-698-5611



4B Asia Pacific

Build No.899/1 Moo 20
Soi Chongsiri
Bangplee-Tam Ru Road
Tanbon Bangpleeyai
Amphur Bangplee
Samutprakarn 10540
Thailand
Tel: +66 (0) 2173-4339
Email: 4b-asiapacific@go4b.com



4B China 4B 中国公司

中国江苏省常州市
武进高新技术产业开发区
西湖路8号
津通国际工业园5A一层
Tel: +86-519-88556006
Email: 4b-china@go4b.com



4B Australia

Building 1, 41 Bellrick Street
Acacia Ridge,
4110, Queensland
Australia
Tel: +61 (0) 7 3216 9365
Email: 4b-australia@go4b.com



4B France

9 Route de Corbie
80800 Lamotte Warfusée, France
Tel: +33 (0) 3 22 42 32 26
Email: 4b-france@go4b.com



4B Deutschland

9 Route de Corbie
F-80800 Lamotte Warfusée, France
Tel: +49 (0) 2333 601 681
Email: 4b-deutschland@go4b.com



4B Africa

14 Newport Business Park
Mica Drive
Kya Sand
2163 Johannesburg
South Africa
Tel: +27 (0) 11 708 6114
Email: 4b-africa@go4b.com

Our policy is one of continuous improvement; therefore we reserve the right to amend specification without prior notice. All information contained herein is provided in good faith and no warranty is given or implied. E&OE.