

WATCH DOG



elite

BUCKET ELEVATOR
& Belt Conveyor
MONITOR SYSTEM

INSTALLATION/OPERATION MANUAL

WDC3NV46CAI & WDC3NV4CAI

Revision R9 – Jan 2015

APPROVALS

The Watchdog Control Unit

Hazardous locations – see page 41

WARNING: The Watchdog uses an LCD type display,
therefore exposure to direct sunlight must be avoided.



www.go4b.com

US: 309-698-5611

UK: +44 (0) 113 246 1800

F: +33 (0) 3 22 42 32 26

D: +49 (0) 700 224 24091



Pulley
Alignment

Bearing
Temperature

Plug
Condition

Belt Speed and
Alignment
(Head and Boot)

WATCH DOG
elite

1 SPECIFICATIONS 5

1.1 Control Unit 5
 1.1.1 Electrical Ratings 5
 1.1.2 Dimensions 5
 1.1.3 LCD - Liquid Crystal Display 5
 1.1.4 Touch Buttons 5
 1.1.5 LED Status Lamps 6
 1.1.6 Communications Port 6
 1.1.7 System Parameters 6
 1.2 Elevator Motion Probe 7
 1.3 Bearing Temperature Sensor 7
 1.4 Bearing Temperature Sensor - Hazardous Locations 8
 1.5 NTC Bearing Temperature Sensor 8
 1.6 Plug Switch 8
 1.7 Head Pulley Alignment Sensors 8

2 WATCHDOG INSTALLATION INSTRUCTIONS 9

2.1 Introduction 9
 2.2 Installation & Wiring - Non-Hazardous Areas 17
 2.3 Hazardous Locations 17
 2.4 Operation & Adjustment in Hazardous Locations 17

3 ELECTRICAL WIRING 19

3.1.1 Block Diagram - Non - Hazardous Locations 19
 3.1.2 Block Diagram - Class II Hazardous Locations 19
 3.2 Wiring Requirements 20
 3.3 Wiring Details 20
 3.3.1 Control Wiring - Diagram 'I' 20
 3.3.2 Sensor Wiring - Diagram 'J' 22
 3.3.3 Multiple Control Units to a Single Alarm Device - Diagram 'K' 24
 3.4 Printed Circuit Board Details 25

4 OPERATING INSTRUCTIONS 26

4.1 First time use & Initial Calibration 26
 4.2 Re-Calibration 26
 4.3 Wrong Calibration 26
 4.4 Setting the Watchdog Parameters 27
 4.4.1 'Engineer' Setup 27
 4.4.2 'Factory' Setup 27

4.5	Engineer Adjustable Operating Parameters	27
4.5.1	Scale Factor	27
4.5.1.1	Example 1: Percentage	28
4.5.1.2	Example 2: Tons/Hour	28
4.5.1.3	Example 3: Feet/Minute	28
4.5.1.4	Example 4: Metres/Minute	28
4.5.1.5	Example 5: Cubic Metres/Hour	28
4.5.1.6	Example 6: Tones/Hour	29
4.5.1.7	Example 7: Bushels/Hour	29
4.5.1.8	Example 8: Cubic Feet/Hour	29
4.5.2	Underspeed Alarm	30
4.5.3	Underspeed Stop	30
4.5.4	Overspeed Alarm	30
4.5.5	Overspeed Stop	30
4.5.6	Startup Delay	30
4.5.7	Number of MAS	30
4.5.8	Misalignment Sensing	30
4.5.9	Number of HBS zones	30
4.5.10	Plug Switch	30
4.5.11	Head Pulley Alignment Sensor	30
4.5.12	Comms ID	30
4.6	Factory Adjustable Operating Parameters	31
4.6.1	Engineer Code	31
4.6.2	Acceleration Monitoring	31
4.6.3	Stop on Hot Bearing	31
4.6.4	Type of Thermistor	31
4.6.5	Speed Range	31
4.6.6	Smoothing Factor	31
4.6.7	Misalignment Delay	31
4.6.8	Misalignment Ratio	31
4.6.9	Persistent Alarm Delay	31
4.6.10	Relay Delay	31
4.6.11	Overspeed Alarm Delay	31
4.6.12	Overspeed Stop Delay	31
4.7	The 'Test' Function	32
4.7.1	Test Settings	32
4.7.2	Full Test	32
4.8	Normal Operation	32
4.8.1	Motion Probe Connections & Probe LEDs	32
4.8.2	Starting & Accelerating	33
4.8.3	Underspeed Detection	33
4.8.4	Overspeed Detection	33
4.8.5	Misalignment Detection	34
4.8.6	Bearing Over-Temperature Detection	34
4.8.7	Persistent Alarm Conditions	34
4.8.8	Stop (Shutdown) Conditions	35
4.8.9	Power-Fail Conditions	35

5	CHECK LIST (For Problems after Initial Start-up)	36
6	FAULT FINDING CHART	37
7	WARNING MESSAGES	38
8	LIABILITY & WARRANTY	39
9	MOUNTING BLOCK TEMPLATE	40
10	HAZARDOUS LOCATIONS	41
11	NTC TEMPERATURE MONITORING	42



Dear 4B Customer:

Congratulations on your purchase. 4B appreciates your business and is pleased you have chosen our products to meet your needs.

Please read in its entirety and understand the literature accompanying the product before you place the product into service. Please read the safety precautions carefully before operating the product. With each product you purchase from 4B, there are some basic but important safety considerations you must follow to be sure your purchase is permitted to perform its design function and operate properly and safely, giving you many years of reliable service. Please read and understand the Customer Safety Responsibilities listed below. Failure to follow this safety directive and the Operation Manuals and other material furnished or referenced, may result in serious injury or death.

SAFETY NOTICE TO OUR CUSTOMERS

- A. In order to maximize efficiency and safety, selecting the right equipment for each operation is vital. The proper installation of the equipment, and regular maintenance and inspection is equally important in continuing the proper operation and safety of the product. The proper installation and maintenance of all our products is the responsibility of the user unless you have asked 4B to perform these tasks.
- B. All installation and wiring must be in accordance with Local and National Electrical Codes and other standards applicable to your industry. (Please see the article “Hazard Monitoring Equipment Selection, Installation and Maintenance” at www.go4b.com.) The installation of the wiring should be undertaken by an experienced and qualified professional electrician. Failure to correctly wire any product and/or machinery can result in the product or machine failing to operate as intended, and can defeat its design function.
- C. Periodic inspection by a qualified person will help assure your 4B product is performing properly. 4B recommends a documented inspection at least annually and more frequently under high use conditions.
- D. Please see the last page of this manual for all warranty information regarding this product.

CUSTOMER SAFETY RESPONSIBILITIES

1. READ ALL LITERATURE PROVIDED WITH YOUR PRODUCT

Please read all user, instruction and safety manuals to ensure that you understand your product operation and are able to safely and effectively use this product.

2. YOU BEST UNDERSTAND YOUR NEEDS

Every customer and operation is unique, and only you best know the specific needs and capabilities of your operation. Please call the 24-hour hotline at 309-698-5611 for assistance with any questions about the performance of products purchased from 4B. 4B is happy to discuss product performance with you at any time.

3. SELECT A QUALIFIED AND COMPETENT INSTALLER

Correct installation of the product is important for safety and performance. If you have not asked 4B to perform the installation of the unit on your behalf, it is critical for the safety of your operation and those who may perform work on your operation that you select a qualified and competent electrical installer to undertake the installation. The product must be installed properly to perform its designed functions. The installer should be qualified, trained, and competent to perform the installation in accordance with Local and National Electrical Codes, all relevant OSHA Regulations, as well as any of your own standards and preventive maintenance requirements, and other product installation information supplied with the product. You should be prepared to provide the installer with all necessary installation information to assist in the installation.

4. ESTABLISH AND FOLLOW A REGULAR MAINTENANCE AND INSPECTION SCHEDULE FOR YOUR 4B PRODUCTS

You should develop a proper maintenance and inspection program to confirm that your system is in good working order at all times. You will be in the best position to determine the appropriate frequency for inspection. Many different factors known to the user will assist you in deciding the frequency of inspection. These factors may include but are not limited to weather conditions; construction work at the facility; hours of operation; animal or insect infestation; and the real-world experience of knowing how your employees perform their jobs. The personnel or person you select to install, operate, maintain, inspect or perform any work whatsoever, should be trained and qualified to perform these important functions. Complete and accurate records of the maintenance and inspection process should be created and retained by you at all times.

5. RETAIN AND REFER TO THE OPERATION MANUAL FOR 4B'S SUGGESTED MAINTENANCE AND INSPECTION RECOMMENDATIONS

As all operations are different, please understand that your specific operation may require additional adjustments in the maintenance and inspection process essential to permit the monitoring device to perform its intended function. Retain the Operation Manual and other important maintenance and service documents provided by 4B and have them readily available for people servicing your 4B equipment. Should you have any questions, please call the 4B location who supplied the product or the 24-hour hotline number in the USA -309-698-5611.

6. SERVICE REQUEST AND ONLINE PRODUCT REGISTRATION

If you have questions or comments about the operation of your unit or require the unit to be serviced please contact the 4B location who supplied the product or send your request via fax (309-698-5615), email (4b-usa@go4b.com), or call us via our 24-hour hotline number in the USA - 309-698-5611. Please have available product part numbers, serial numbers, and approximate date of installation. In order to assist you, after the product has been placed into service, complete the Online Product Registration section which is accessed via our website www.go4b.com

INTRODUCTION

“Watchdog” Motion, Alignment and Temperature System

The 'Watchdog' system is a user-programmable, microprocessor controlled bucket elevator monitor. The control unit accepts signals of speed and alignment from elevator buckets or elevator bolts. Additional signals of bearing temperature, plugged chute and head pulley alignment are able to effect an alarm and provide shutdown control of the elevator, and or feeding system, when hazardous conditions are detected. Microprocessors and electronics are housed in a self-contained wall-mounting enclosure, and the motion/alignment sensors, temperature sensors, plugged chute sensors and pulley alignment sensors are separate items for mounting on the elevator.

Abbreviations used in this manual:

PPM Pulses per Minute
LCD Liquid Crystal Display
BPH Bushels per Hour
LED Light Emitting Diode
HBS Hot Bearing Sensor
MAS Motion Alignment sensor
PLC Programmable Logic Controller
HPAS Head Pulley Alignment Sensor

Motion Sensing - General Features

The Watchdog accepts signals from between one and four probes mounted on the bucket elevator. A probe will provide one pulse for every ferrous object detected, (e.g. a bucket or bolt) which passes within its sensing range. The Watchdog compares the speed given by these input signals with a preset value, (the 'calibrated speed') and is able to affect an alarm or shutdown if there is a deviation from the Calibrated speed of more than the programmed percentage. These percentages are fully user-selectable. A digital display of speed is provided on the front panel of the Watchdog which can be scaled as required by a programmable Scale Factor. The Watchdog also accepts a signal from the motor starter which will initiate a programmable start-up timer. During this start-up time the speed is monitored and if insufficient acceleration is detected, (e.g. due to a blockage) a stop signal will be generated to shut down the elevator leg. A full test feature is also provided on the Watchdog Control Unit. This test feature displays the programmed percentages and actively tests the internal and external alarm and shutdown circuits.

Alignment Sensing - General Features

Two probes mounted on the elevator will detect belt speed from the pulses generated by the passing buckets or bolts. If the elevator belt becomes misaligned, one of the probes will fail to detect the buckets or bolts. The control unit will recognise the absence of pulses as a misalignment condition, display the location of the misalignment and will affect an alarm signal, which can eventually result in shutdown of the elevator and other equipment.

Alignment can be detected by either one pair of probes mounted at the top OR bottom of the elevator, or by two pairs of probes, one set at the bottom AND one set at the top.

Temperature Sensing - General Features

The Watchdog has inputs for up to six zones of temperature sensors. Each of the elevator shaft bearings can be fitted with a temperature sensor to detect overheating. Sensors can also be fitted to detect the temperature of oil in a gearbox, etc. The temperature sensors have a preset switching temperature, which if exceeded, causes an alarm followed by an elevator shutdown if the condition persists. Additionally, special NTC Thermistor Sensors are available which provide a linear output for the control unit to display the temperature of the bearings.

Serial Communications - General Features

The Watchdog can be connected to a 'Host' computer or PLC via a serial link (RS422/485) which enables remote two-way communication with the Watchdog.

Installation

When installing the 'Watchdog' system we strongly advise that you employ the services of a certified and licensed electrician, who is familiar with installation of electronic controls. If assistance is required in obtaining an installation electrician please contact us and we will recommend an electrical contractor.

Control Unit Dimensions



1. SPECIFICATIONS

1.1 The Control Unit WDC3NV4CAI and WDC3NV46CAI

A polycarbonate enclosure houses the electronics, displays, and the terminal connectors. The watchdog contains two printed circuit boards. A lower board accommodates the power supply circuitry, output relays and opto-isolators for the input signals. The upper board is mounted in the hinged lid and houses the microprocessors and the circuitry associated with the display and touch buttons. The two boards are connected by a short ribbon cable. In normal use there are no adjustments required inside the case, all settings being performed via the front panel touch buttons.



CAUTION
DO NOT REMOVE COVER WHILE CIRCUITS ARE LIVE.
REPLACE COVER AND TIGHTEN SCREWS
BEFORE APPLYING POWER.



1.1.1 Electrical Ratings

TABLE 1

Electrical Supply	- 24VDC WDC3NV4CAI - 24 VDC or 100 to 260 VAC WDC3NV46CAI
Power Consumption	- 12 Watts maximum (V4) 25 Watts (V46)
Starter Interlock Input	- 24 VDC or 110V +/- 10% 50/60Hz 2.5mA or 220V +/- 10% 50/60Hz 5mA
Alarm Relay Contacts	- 1 Pole changeover 240V AC , 10 A max
Stop Relay Contacts	- 1 Pole changeover 240V AC , 10 A max
Additional relay contacts for under speed, misalignment, and bearing temperature are available with the optional PLC Interface Board.	
Probe Inputs	- 24V DC Approx.
Probe Supply	- 24V DC Approx. Current 200 mA available
Protection	- V4 : ATEX and IECEx Ex II 2DEx tb IIIC T125 °C Db IP66 Tamb -20 °C to +50 °C - V4 : CL II DIV 1 E,F & G (When used with a Class2 power supply) - V46: ATEX and IECEx Ex II 3D Ex tc IIIC T125 °C Dc IP66 TAMB -20 °C to +45 °C - V46: CLII DIV2 F&G

1.1.2 Dimensions

TABLE 2

HEIGHT	12.1" 9.5" 5.4"	308mm WIDTH 241mm DEPTH 137mm
HOLE CENTRES	10.75" x 6"	273 mm x 153 mm
CABLE ENTRY	2 HOLES @ 1"	25.5 to 26mm
WEIGHT	6lbs	2.8 kg

1.1.3 LCD - Liquid crystal display

This is viewed through the front panel. It is used for displaying status messages, menu options and the values of preset parameters.

1.1.4 Touch buttons

The menu system is controlled by using the touch buttons on the front of the unit:

TABLE 3

Red	- Touch Pad 'A' - or UP
Yellow	- Touch Pad 'B' - or DOWN
Green	- Touch Pad 'C' - or ENTER

The Touch button pads use the very latest in touch switch technology. They are designed to work with the human finger. If dirt or moisture come in contact or build up on the touch sensor pads, then the electronics will self re-calibrate and remove the effects of the dirt/moisture resulting in normal operation once more.

1.1.5 LED Status Lamps - viewed through front panel

TABLE 4

Green	Top left probe	Green	Top right probe
Yellow	Lower left probe	Green	Lower right probe
Red	Alarm lamp		
	Stop lamp		

1.1.6 Communications Port

The Watchdog has a RS422/RS485 communications port for a serial connection to a host computer. The connections are shown below:

TABLE 5

Receive from host (Rx)	+A	-B
Transmit to host (Tx)	+Y	-Z

For further information on serial comms with the Watchdog, refer to data sheet WDD 1.1.6 (available from 4B).

1.1.7 System Parameters

The Watchdog is normally supplied with its programmable parameters preset to default values. Table 6 shows the available 'engineer' range of adjustment of each parameter. The range is selected through the main menu 'Setup' option. Each unit is supplied with an

'Engineer's' access code to enable on site programming. Special Customized on-site 'Factory' programming is available by calling 4B/Braime/Setem. (Phone numbers on front of manual).

TABLE 6

Parameter	Units	Default Settings	Engineer range Min	Engineer range Max
Scale Factor	-	12.00	0.01	99.99
Underspeed alarm	%	10	5	20
Underspeed stop	%	20	5	20
Over calibrated alarm speed	%	10	5	20
Over calibrated stop speed	%	20	5	20
Start up delay	Seconds	10	1	30
Number of MAS	-	2	1	4
Number of HBS zones	-	6	0	6
Comms ID	-	1	1	32
Speed Range	PPM	2000	-	-
Smoothing factor	-	10	-	-
Misalignment delay	Seconds	6	-	-
Acceleration Monitoring	-	Yes	Factory	
Stop on Hot Bearing (No Delay)	-	No	Adjustment	
Misalignment ratio	%	66	Only	-
Persistent Alarm delay	Seconds	180	-	-
Relay delay	Seconds	1.5	-	-
Overspeed alarm delay	Seconds	10	-	-
Overspeed stop delay	Seconds	20	-	-
Type of Thermistor		PTC	PTC	NTC
Plug Switch	-	No	Yes	No
Pulley Alignment	-	No	Yes	No

1.2 The Elevator Motion Probe - WDA3V34CAI

The probe is designed to detect moving ferrous targets which pass within its sensing range. It will not detect non-ferrous materials such as plastics, rubber, stainless steel, aluminium, etc., and it will not detect a stationary or slow moving object. It is designed to detect steel elevator buckets, from the side or front of the elevator leg steel bolts used to attach non-metallic buckets to the elevator belt, by sensing from the back of the belt. With two probes correctly mounted, belt misalignment can also be detected.

Contained within the probe is a powerful magnet and an electronic detector circuit. The enclosure is manufactured from stainless steel and all of the components are rigidly encapsulated in epoxy resin. A six conductor cable is attached to the outer end of the probe and a threaded conduit bushing is used to permit the use of flexible conduit systems for cable protection. An LED is moulded into the outer end of the probe and this is arranged to flash each time a target is detected; this LED enables easy adjustment of the probe, and an adjusting screw is provided to enable the sensitivity of the probe to be altered. The maximum and minimum limits of the adjusting screw can be felt by positive stops. A clamp block is provided to attach the probe to the elevator panels and to allow easy sliding adjustment of sensing distance. Performance details and dimensions are shown in Table 7.

TABLE 7 ELEVATOR MOTION PROBE

ELECTRICAL SUPPLY	-	12/24 V DC Approx. From Control Unit
SUPPLY CURRENT	-	65ma (max at 24 V)
OUTPUT SIGNAL	-	12/24 V DC Approx. Pulsed (dependent upon supply)
MIN. TARGET SIZE	-	25mm Dia. (1" Dia.)
MAX. TARGET DISTANCE	-	75mm Approx (3" approx.). (for 25mm Dia (1"). Target)
MIN. TARGET SPEED	-	20 Ft/Min. (0-1 meters/second)
MAX. TARGET SPEED	-	2000 Ft/Min. (10 meters/second)
MAX. PULSE RATE	-	2000 Per Min. (High Speed Probes Available)
DIAMETER	-	50 mm (approx. 2")
LENGTH	-	150mm (approx. 5 ¾ ")
WEIGHT	-	0.7Kg (24oz)
CABLE	-	3m Long (9ft Long)
CONDUIT ENTRY	-	1/2" NPT thread, (1/2" NPT to 20 mm adapter available)
PROTECTION	-	ATEX Ex II 2D T125°C Tamb -20°C to +50°C
	-	IECEX DIP DIP A21 T125°C IP66
	-	CSA CL2 DIV1 GP's E, F & G

1.3 Bearing Temperature Sensor - WDB14V3AI

The temperature Sensor is designed to screw into the bearing housing in a grease nipple hole or other tapped hole and will detect excessive temperature of the bearing housing. The sensor contains a positive temperature coefficient (PTC) Thermistor which has a fixed switching temperature. Below this switching temperature, the Thermistor has a low electrical resistance and above this temperature it has a very high resistance. The system fails to safe, as if the wire is broken at one of the sensors, an alarm signal is generated. A two conductors PVC covered cable is permanently attached to the sensor body. A grease nipple is provided in the body of the sensor to allow greasing of the bearing in the normal manner.

TABLE 8 WDB14V3AI BEARING SENSORS

SWITCHING TEMPERATURE	-	80°C + 5°C (Others are available)
RESISTANCE AT 60°C	-	250 Ohms Max
RESISTANCE AT 100°C	-	2000 Ohms Min
SENSING VOLTAGE	-	12V DC Approx.
MAX. CURRENT	-	20ma
MOUNTING THREAD	-	1/8" NPTF
CABLE	-	2 Conductors 10ft (3 Mtr.) Long
WEIGHT	-	7 oz. (0.2 Kg)
PROTECTION	-	ATEX Ex II 1D T125°C
	-	CSA /cus Class 2 Div 1 Group E, F, and G

1.4 Bearing Temperature Sensor - WDB24V3CA

The temperature sensor is designed to screw into the bearing housing in a grease nipple hole or other tapped hole and will detect excessive temperature of the bearing housing. The sensor contains a positive temperature coefficient (PTC) Thermistor which has a fixed switching temperature. Below this switching temperature, the Thermistor has a low electrical resistance and above this temperature it has a very high resistance. The system fails to safe, as if the wire is broken at one of the sensors, an alarm signal is generated. A two conductors cable is permanently attached to the sensor body. The steel body is provided with a 1/2" NPT conduit entry for use with liquid tight flexible metal conduit. A grease nipple is provided in the body of the sensor to allow greasing of the bearing in the normal manner.

TABLE 9

SWITCHING TEMPERATURE	- 80°C + 5°C (Other Temperatures are available)
RESISTANCE AT (140oF) 60°C	- 250 Ohms Max
RESISTANCE AT (212oF) 100°C	- 2000 Ohms Min
SENSING VOLTAGE	- 12V DC Approx.
MAX. CURRENT	- 20ma
MOUNTING THREAD	- 1/8 " NPTF
CABLE	- 2 Conductor 6ft (2Mtr.) Long
CONDUIT ENTRY	- 1/2" NPTF
WEIGHT	- 7 oz. (0.2Kg)
PROTECTION	- ATEX Ex II 1D T125°C CSA cus - Class II Division 1, Groups E, F and G

1.5 NTC — Bearing Temperature Sensor

Contact your supplier for the available options.

1.6 Plug Switch

The plug switch is designed to mount on the discharge or inlet spout of the elevator, and to warn of a plug condition. The switch uses a solid state capacitance circuit to detect when material surrounds the end of the polycarbonate housing. A signal is sent back to the control unit, which displays "plug condition" on the LCD display. Contact your supplier for the available options.

1.7 Head Pulley Alignment Sensors

Sensors for monitoring the head pulley alignment, contact your supplier for the available options.

2 WATCHDOG INSTALLATION INSTRUCTIONS

2.1 Introduction

To install the "Watchdog" first check that all of the parts of the system that were ordered have been received -
Control Unit
Motion / Alignment Sensors
Bearing Temperature Sensors

CONTROL UNIT

The control unit should be installed in a suitable location away from excessive heat, moisture and vibration and mounted at an eye level position so that the display and warning lights can be easily seen. There should be sufficient space to open the hinged lid for wiring.



The Control Unit can be susceptible to static voltage. Connection of a clean ground to terminal 16 is essential for optimum performance. Prior to this connection, static handling precautions should be taken.

ATTENTION

ALL WIRING MUST BE IN ACCORDANCE WITH LOCAL AND NATIONAL ELECTRICAL CODES AND SHOULD BE UNDERTAKEN BY AN EXPERIENCED AND PROFESSIONAL, QUALIFIED ELECTRICIAN.

IMPORTANT

You must observe all warnings indicated in this manual. Failure to do so will void manufacturer's warranty and may cause serious injury or death.

The certification of this product does not permit the drilling/punching of additional cable entry holes into the body of the enclosure. To do so will void both certification and warranty and may cause serious injury or death.

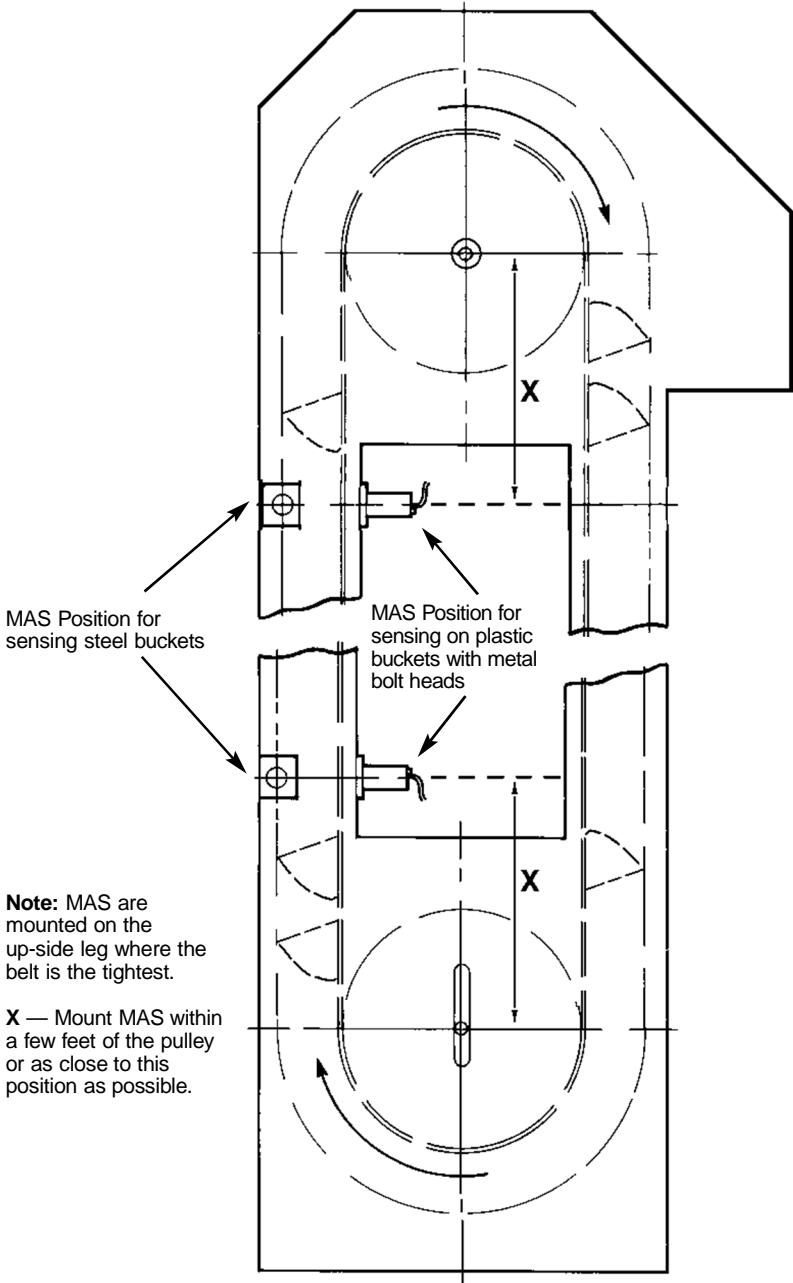

**TYPICAL PROBE SENSING POSITIONS
ON UP LEG OF ELEVATOR**

DRG. A

Steel Buckets

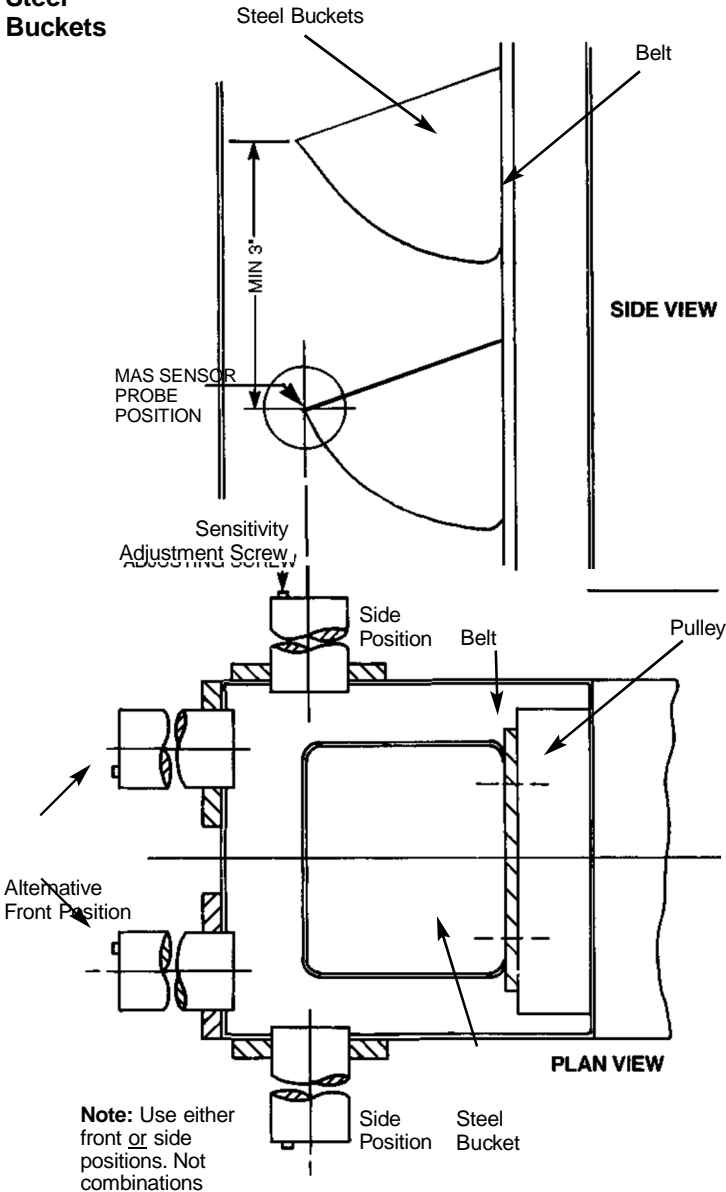

MAS SENSOR POSITIONS FOR BELT ALIGNMENT AND BELT SLIP SENSING WITH ELEVATOR STEEL BUCKETS

DRG. B

Plastic Buckets

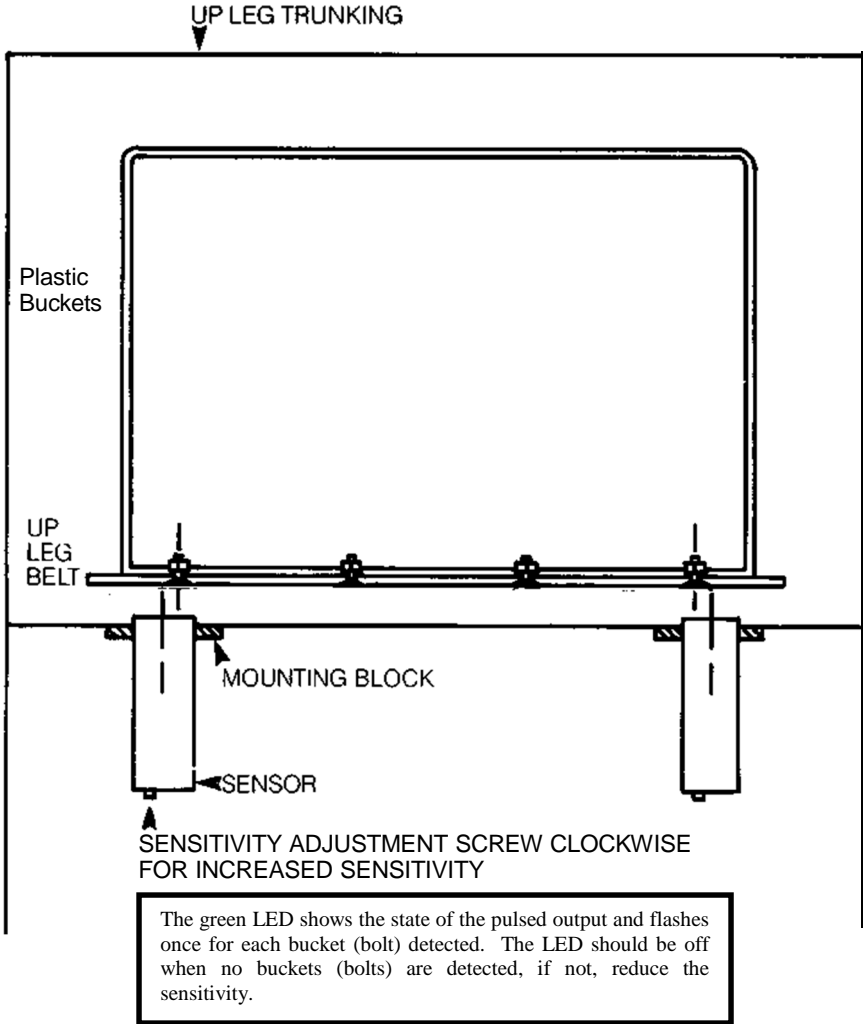

PLAN VIEW

**MAS SENSOR POSITIONS
FOR BELT ALIGNMENT AND BELT SLIP SENSING
ON PLASTIC BUCKETS WITH STEEL BOLTS**

DRG. D

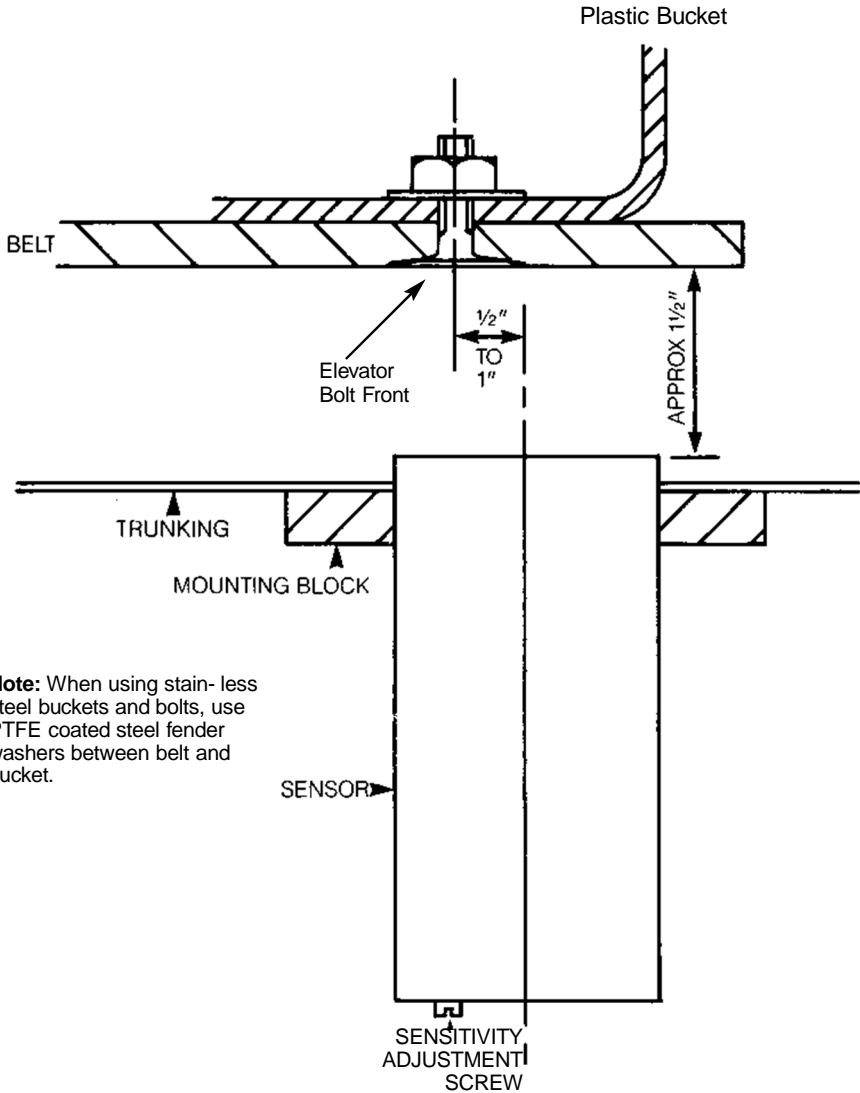

Note: When using stainless steel buckets and bolts, use PTFE coated steel fender washers between belt and bucket.

PLAN VIEW

**WATCHDOG ELITE MAS POSITION
FOR BELT ALIGNMENT
SENSING ON BOLTS**

DRG. E

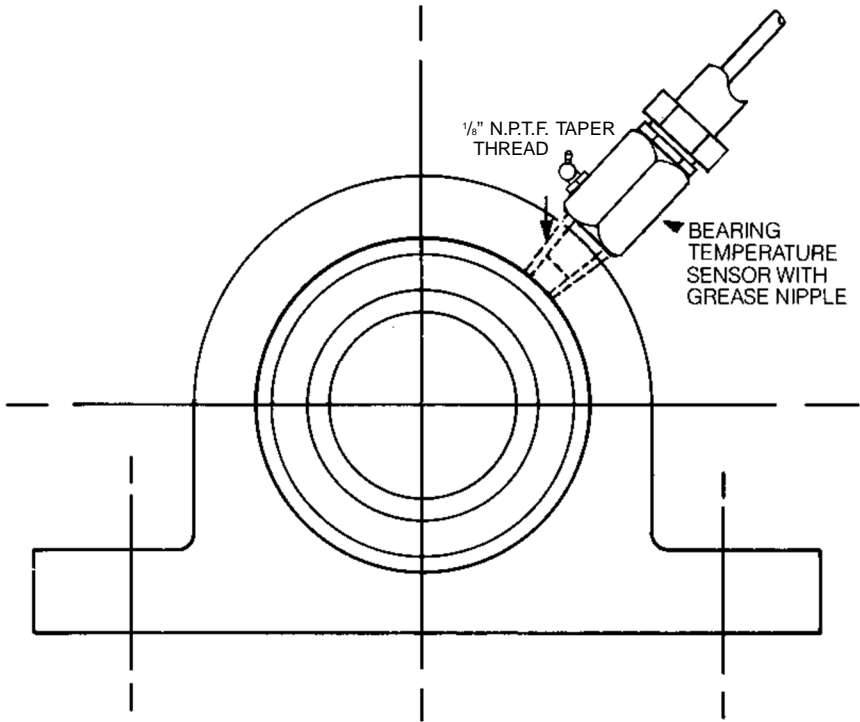

INSTALLATION OF BEARING TEMPERATURE SENSOR

DRG. F

NOTE

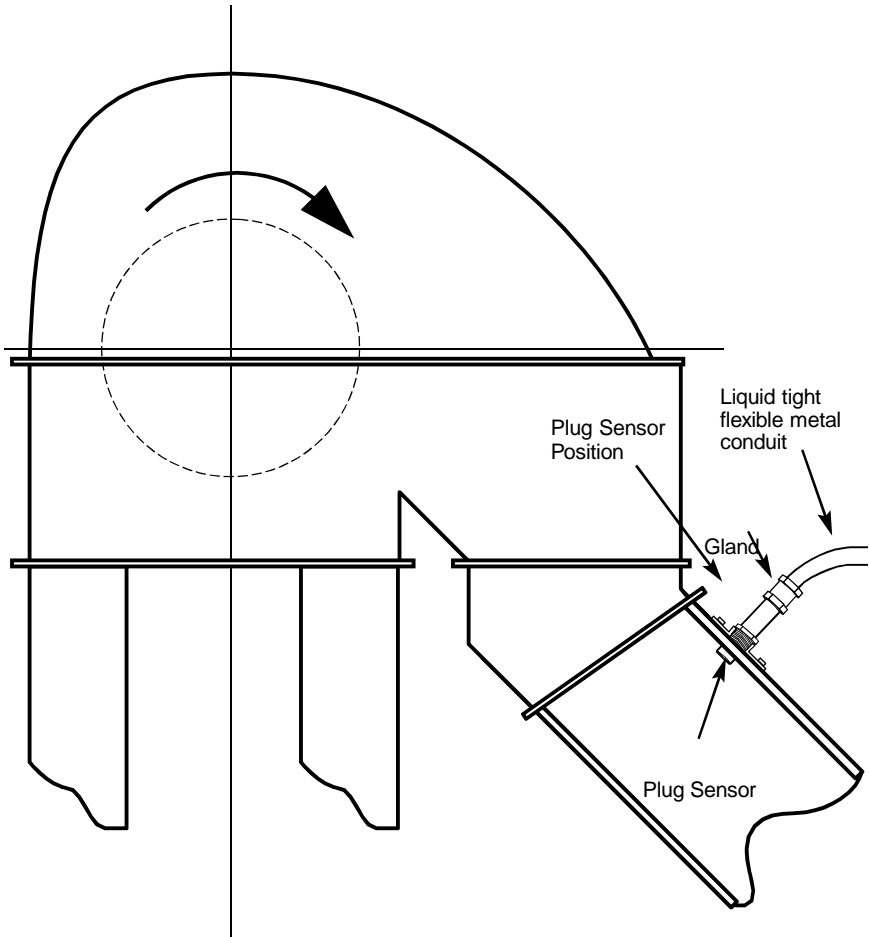

ELEVATOR PLUG SENSOR
SHOWN AT ELEVATOR HEAD.

DRG. G

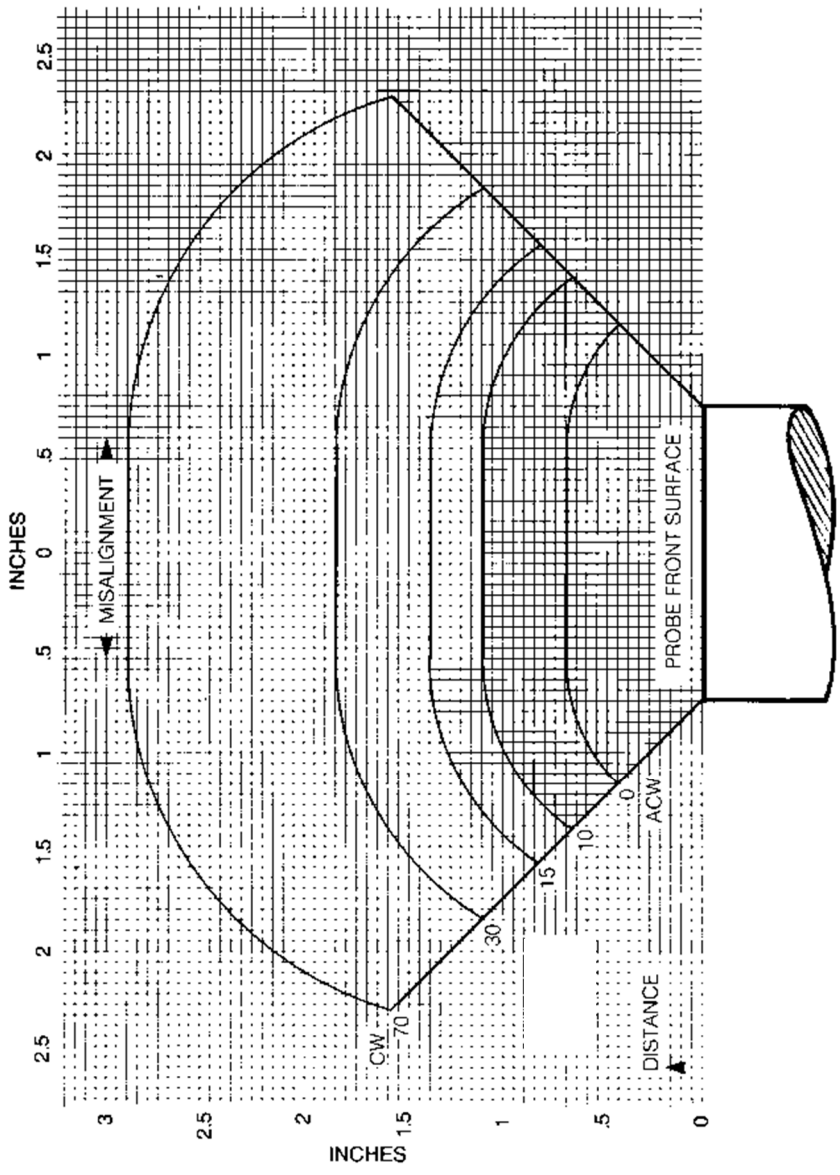

2.2. Installation and Wiring - Non Hazardous Areas

MAS probes should be mounted in a position which is accessible for adjustment, and protected from possible damage. As the probes may have to be moved slightly during adjustment, the wiring to them must be in flexible conduit. Mount a conduit junction box within 10ft (3 meters) of the motion probe - generally one junction box can be used for a pair of motion probes. Connect the probe(s) to the junction box using flexible conduit. Connect the junction box back to the control unit using either conduit or cable suitable for permanent wiring.

The **temperature probes** should be installed to the bearing housing in place of the bearing grease nipple. The sensor is grease-through to allow greasing of the bearing. Mount a junction box within 10 ft (3 metres) of each probe (or each pair of probes). Connect the flexible cable from the temperature probe into the junction box using a strain relief cable gland. Connect the junction box back to the control unit using either rigid conduit or cable suitable for permanent wiring.

Note: The wiring between the motion probes, temperature sensors, and control unit has to be suitable for low level electrical signals (nominally 24 volts DC) and care should be taken to avoid electrical interference from other equipment. These wires should be run in either rigid steel conduit, without any other cables, or should be run with shielded wires, the shield being grounded at one end only. **We strongly recommend the use of shielded wires when wiring the motion probes to the microprocessor control unit.**

The **control unit** is designed for wall mounting either in a control room or near to the motor start equipment. However, as with all computerised systems care should be taken not to expose the microprocessor unit to excessive ambient temperatures, or potential electrical interferences. It should be located where it is readily accessible for set-up and adjustment. The two conduit entries are suitable for 3/4" conduit, but as the enclosure of the control unit is non-metallic, no ground continuity is provided through the enclosure. Each conduit must be terminated in a suitable bushing which provides ground continuity such as Allen-Bradley- 1490-N19.

2.3. Hazardous Locations

The Watchdog has been designed for use in certain hazardous locations, where the hazard is known to be Ignitable Dust.

If the Watchdog equipment is to be used on an elevator which will be handling grain or similar products, it is likely that the atmosphere inside the elevator leg during normal use will contain ignitable dust in suspension in the air. This area within the elevator leg is normally defined as a Category 1 hazardous location.

If the elevator is contained within a building where ignitable dust is not normally in suspension in the air but can accumulate normally on the surfaces of equipment, this can also be hazardous. This location is normally defined as a Category 2 hazardous location.

Watchdog Control Unit type WDC3NV4A1 is approved for use in:
EX II 2D Ex tb IIIC T125°C Db and IECEx A21 Ex tb IIIC T125°C Db locations

Watchdog Control Unit type WDC3NV46A1 is approved for use in:
EX II 3D Ex tD A22 T125°C Dc and IECEx A22 EX II 3D Ex tD A22 T125°C Dc locations

The Watchdog MAS Probe is approved for use in:
CSA CLII DIV1 GP's E, F & G
EX II 1D T125°C and IECEx DIP DIP A20 Ta 125°C locations

The Temperature Sensor Probe is approved for use in
CSA CLII DIV1 GP's E, F & G
EX II 1D T125°C locations

Installation and Wiring - Hazardous Locations

Consult the national electrical standards prior to installation.

MAS probes should be mounted in a position which is accessible for adjustment, and protected from possible damage. As the probes may have to be moved slightly during adjustment, the wiring to them must be in liquid-tight flexible metal conduit with approved fittings. Mount a dust tight conduit junction box within 10ft (3 meters) of the motion probe generally one junction box can be used for a pair of motion probes. Connect the probe(s) to the junction box using liquid tight flexible metal conduit with approved fittings. Connect the junction box back to the control unit using either conduit or cable suitable for permanent wiring and ensure that dust tight seals are used.

Temperature probes installation into the bearing housings should be done generally as described in paragraph 2.1. Mount a dust tight conduit junction box within 10ft (3 meters) of each probe (or each pair of probes). Connect the flexible cable from the temperature probe into the conduit junction box using a strain relief cable gland (cord clamp) which meets dust tight requirements. Connect the junction box back to the control unit using either conduit or cable suitable for permanent wiring and ensure that dust tight seals are used. The installation of the Category 1 temperature sensor probes is identical to that on the standard temperature probe except that dust/liquid tight flexible metal conduit with approved fittings is required between the temperature probe(s) and the conduit junction box.

The wiring between the motion probes, temperature probes and control unit has to be suitable for low level electrical signals (nominally 24 volts DC), and care must be taken to avoid electrical interference from other equipment. If rigid steel conduit is used, do not run any other cables in the same conduit. Avoid running the signal wiring near any motor cables or other heavy power cables.

We strongly recommend the use of shielded wires when wiring the motion probes to the microprocessor control unit.

2.4 Operation and Adjustment in Hazardous Locations

The motion probes can be adjusted for physical position on the elevator leg, but great care must be taken to ensure that there is no possibility of the elevator belt or buckets striking and damaging the motion probes.

Due to electrical shock and dust hazards, the control unit must not be opened whilst power is applied. Before unfastening the main lid of the unit, switch off the power and wait for a few minutes. The lid can then be hinged to give access to the terminal connections.

With the control unit lid closed, set-up adjustments are made via the three front panel touch button pads.

The supply to the external sensors is protected by two fuses. F1 protects the motion probes and F2 protects the bearing temperature sensors. These fuses are rated as T5E(T) 200ma and must only be replaced with identical devices.

3.2 Wiring requirements

- (i) Voltage to Control Unit See Model type
- (ii) Sensors to Control Unit
24 Volts DC from Control Unit
Supply Current 1 Amp MAX
6-conductor wire shielded

Note: Avoid running cables near any motor wires as this could cause false signals.

3.3 Wiring details

1. NOTE: Starter Interlock:

In all cases a voltage must be applied across terminals 6 and 7 when the motor is running to establish the starter interlock. See table 1, Electrical ratings. This causes the alarm and stop relays to energise and activates the speed measuring circuit and the start-up delay. When the motor is stopped, the voltage across terminals 6 and 7 should not be present.

3.3.1 Diagram I: Control Wiring

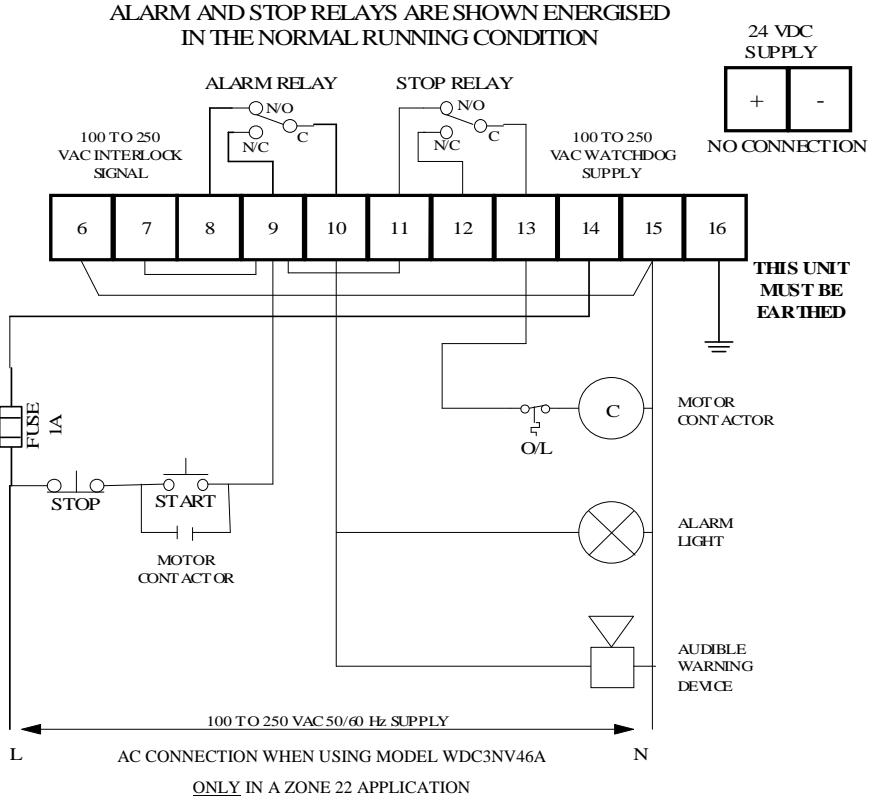

ALARM AND STOP RELAYS ARE SHOWN ENERGISED
IN THE NORMAL RUNNING CONDITION

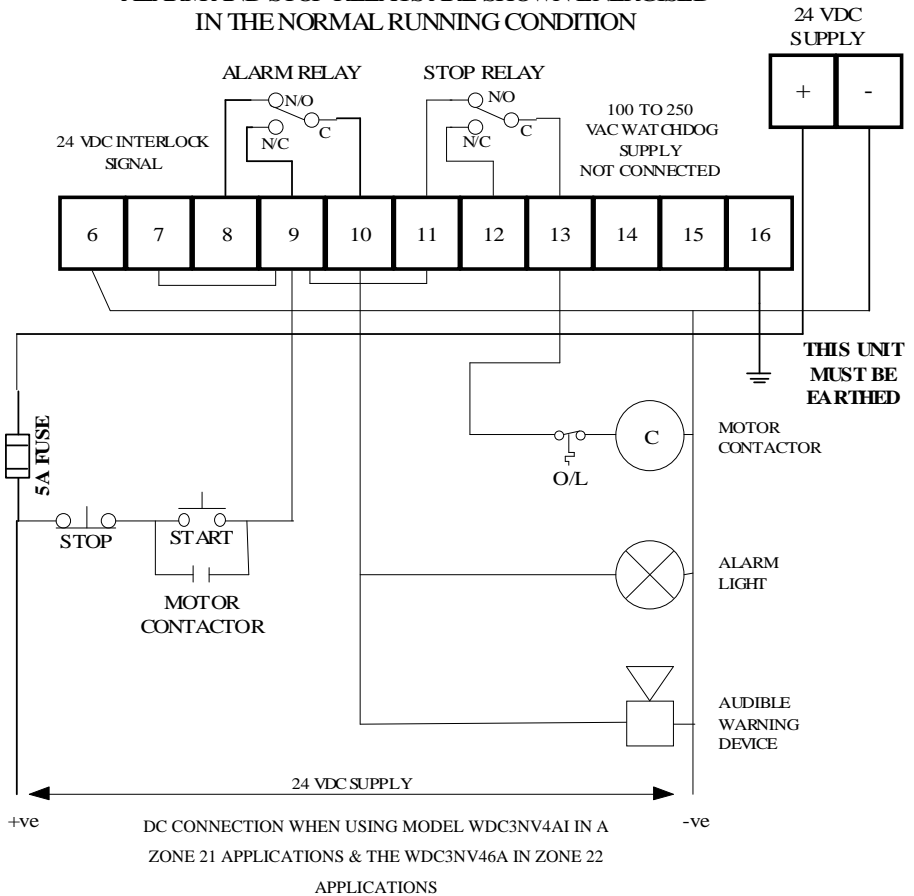

IMPORTANT NOTE!

The system will not function without the starter interlock at Terminals 6 and 7.

3.3.1 Diagram J1 and J2: Sensor Wiring (ATEX and IECEx)

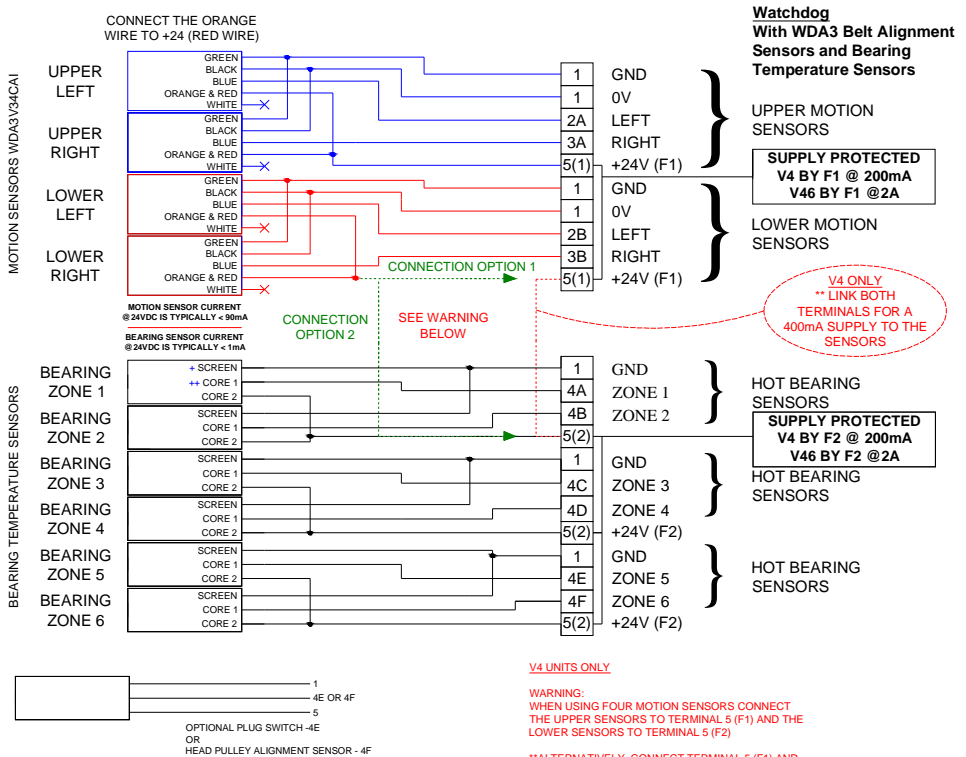

+ Note: SCREEN connection is optional, some sensors only have two core and SCREEN core does not exist.

++ Colours for CORE1 and CORE2 may vary depending on the sensor model. Connection polarity is not important. Please connect all the sensors within the system in the same way to avoid confusion

V4 UNITS ONLY

WARNING: WHEN USING FOUR MOTION SENSORS CONNECT THE UPPER SENSORS TO TERMINAL 5 (F1) AND THE LOWER SENSORS TO TERMINAL 5 (F2)

****ALTERNATIVELY, CONNECT TERMINAL 5 (F1) AND TERMINAL 5 (F2) TOGETHER TO INCREASE THE AVAILABLE CURRENT TO 400mA**

The maximum permitted current for the Watchdog is 400mA. This is a requirement of the ATEX & IECEx standard under which the unit operates. If the sensors used require a supply which is greater than 400mA in total, then it is necessary to use an external approved power supply.

—X Denotes core not connected and should be insulated

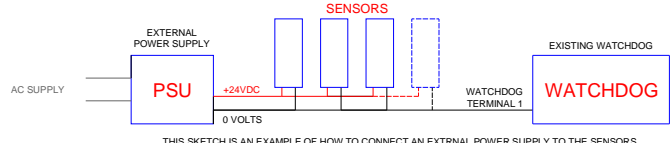

The supply to the external sensors is protected by two fuses. F1 protects the motion sensors and F2 protects the bearing temperature sensors. These fuses are rated as T5R(T) 200 mA and must only be replaced with identical devices.

Three test points are included on the power supply card. +24(F5) is the internal electronics supply and is protected by F5. +24(F2) is the motion sensor supply and is protected by F2. +24(F1) is the bearing sensor supply and is protected by F1.

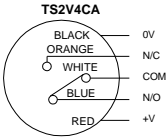

NOTE: THE TOUCHSWITCHES ARE SHOWN IN THE NORMALLY ENERGISED POSITION. WHEN THE BELT MOVES OVER AND ACTIVATES THE TOUCHSWITCH THE CONTACT DE-ENERGISES.

TOUCHSWITCH CURRENT @24VDC IS TYPICALLY < 60mA

BEARING SENSOR CURRENT @24VDC IS TYPICALLY < 1mA

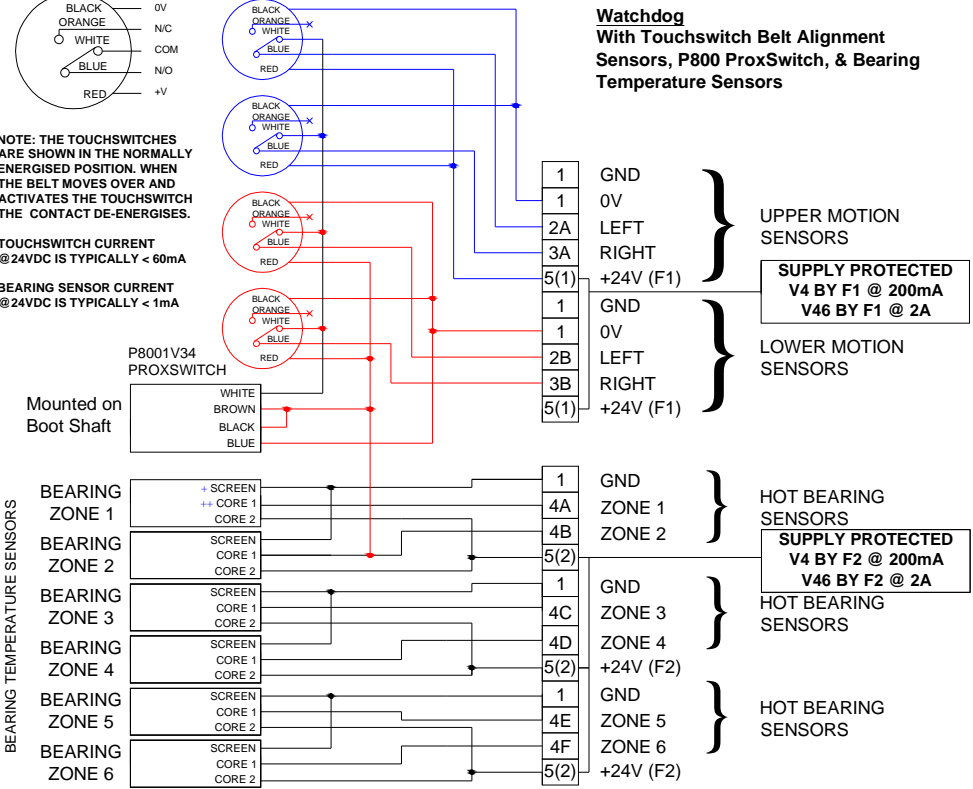

BEARING TEMPERATURE SENSORS

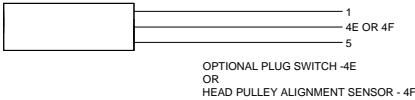

WARNING:
THE TOUCHSWITCH MISALIGNMENT SENSORS ARE DESIGNED TO IMMEDIATELY STOP THE BELT WHEN THEY ARE TOUCHED BY THE MISALIGNED BELT. THEREFORE THE MISALIGNMENT AND PERSISTENT ALARM DELAY SHOULD BE REDUCED TO ZERO.

PROXSWITCH Note -
Proxswitch used to generate pulses for speed and misalignment, through the use of TouchSwitches.

—X Denotes core not connected and should be insulated

V4 UNITS ONLY

WARNING:
WHEN USING FOUR TOUCHSWITCHES CONNECT THE UPPER SENSORS TO TERMINAL 5 (F1) AND THE LOWER SENSORS TO TERMINAL 5 (F2).

****ALTERNATIVELY, CONNECT TERMINAL 5 (F1) AND TERMINAL 5 (F2) TOGETHER TO INCREASE THE AVAILABLE CURRENT TO 400mA.**

The maximum permitted current for the watchdog is 400mA. This is a requirement of the ATEX & IECEx standard under which the unit operates. If the sensors used require a supply which is greater than 400mA in total, then it is necessary to use an external approved power supply.

+ Note: SCREEN connection is optional, some sensors only have two core and SCREEN core does not exist.

++ Colours for CORE1 and CORE2 may vary depending on the sensor model. Connection polarity is not important. Please connect all the sensors within the system in the same way to avoid confusion

This page is intentionally left blank.

3.4 Printed Circuit Board Details

Drawing L

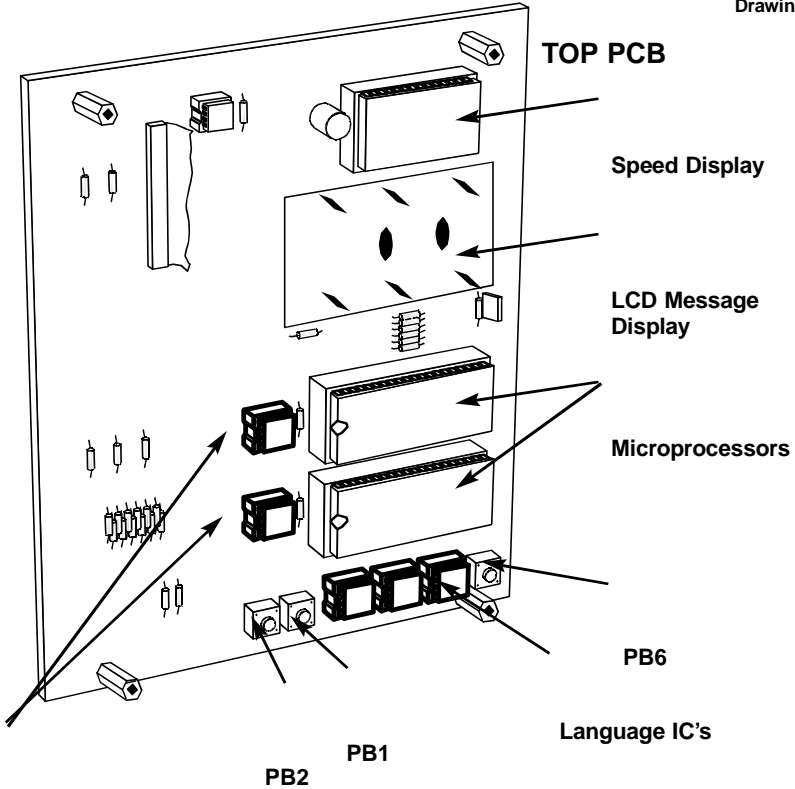

Memory IC's

BOTTOM PCB

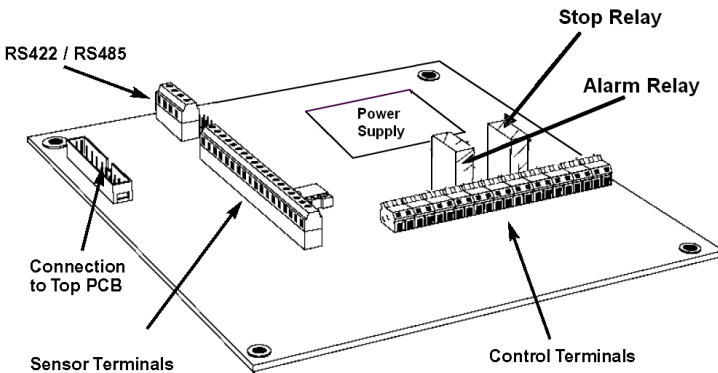

4 OPERATING INSTRUCTIONS

The equipment should have been installed and wired in accordance with the Installation Instructions (Chapter 2) and in accordance with National and Local Codes.

4.1 First time use & Initial Calibration

The Watchdog is normally supplied UNCALIBRATED. When the unit is first connected to its supply this is indicated by a message on the display, "Not Calibrated!... See Manual!" At this time the Alarm lamp should be flashing and the Alarm relay pulsing.

Proceed as follows:-

- (i) Go to the Main Menu by touching button C (green) once. Select the Calibration option by touching button B (yellow) to move the cursor to 'CALIB'.
- (ii) Select 'CALIB' by touching button C (green). Enter the 3-character Calibration access code (A,B,C) that was supplied with the unit. If the code is accepted the LCD will indicate 'Start Elevator to Calibrate'.
- (iii) Operate the START button on the motor starter. This provides an interlock signal to the Watchdog (terminals 6 and 7) which will cause the Alarm and Stop relays to be energised and allow the machine to start. Alarm lamp will continue flashing.
- (iv) The display will indicate the start up delay time. When the start up delay has expired the Alarm lamp will extinguish and the Calibration procedure will start.
- (v) The Calibration procedure takes about 16 seconds, the progress being indicated on the display as a percentage. The Watchdog will measure the rate of input signals from the probes and store an average value of speed (the Calibrated speed) in memory.
- (vi) When the Calibration procedure is complete the unit will go into normal operation. Any change of speed or misalignment or temperature beyond the preset levels will now cause the appropriate ALARM and STOP action. See section 4.4 if it is required to change the preset levels (Watchdog parameters).

WARNING: A full system test should be undertaken (Section 4.7) before the elevator is used in normal operation.

4.2 Re-calibration

You can re-calibrate the Watchdog at any time whilst the machine is running normally by selecting the 'CALIB' option from the Menu as described above and entering the access code. You are strongly advised against indiscriminate re-calibration, as you may be attempting to calibrate the unit whilst the machine is not running normally. If you have persistent alarm/stop conditions there is either something wrong with the machine or with the adjustment of the system.

If the STOP button is operated on the motor starter (interlock signal removed) during calibration, the Alarm and Stop relays will be de-energised and calibration will be aborted. Calibration will also be aborted if any fault conditions occur, ie the elevator fails to start, or stops during the procedure. To start calibration again if this happens, proceed from (i) above after rectifying the fault condition.

4.3 Wrong Calibration

If the unit was calibrated at less than normal speed, it will indicate over-calibration Alarm/Stop conditions and possibly stop the machine when running at normal speed. This indicates that the calibration is wrong and the belt tension should be checked and adjusted as required. The unit should then be re-calibrated (4.2).

If the Watchdog prevents the machine from starting because of wrong calibration, select 'CALIB' from the main menu and enter the CALIBRATION CODE as in 4.1. Wait until the display indicates 'START ELEVATOR TO CALIBRATE' and then start the machine. After a start-up delay the Calibration procedure will begin and when completed the Watchdog will go into normal operation mode. If the Start-up delay is not long enough for the machine to get up to speed then see section 4.4 on how to change it.

4.4 Setting the Watchdog parameters ('SETUP' mode)

Note that when the Watchdog is powered up it reads the stored 'Setup' parameters from its memory. These will be used during operation. If the Watchdog is new it will have been supplied with 'Default' values. The following paragraphs show how these parameters can be viewed or changed.

Touch buttons and an LCD menu display are provided on the front panel of the Watchdog for making adjustments to the system operating parameters. (See section 1.1)

Normally the LCD indicates the system status, eg. 'READY TO RUN'. Go to the Main Menu by touching button C (green). Move the cursor to 'SETUP' option by using touch button B (yellow). Enter 'SETUP' mode by touching button C (green). The menu will then give the options 'Engineer's setup' or 'Factory setup'

Generally whilst in 'SETUP' mode, touch buttons A & B are used to select an option or to change a value, and touch button C is used to accept or enter the choice. If more than about 30 seconds elapses without a button touch, the menu system will resume displaying status messages.

If the Main Menu is displayed it may be aborted by touching button A (Red).

4.4.1 'Engineer' Setup

If 'Engineer' setup mode is selected the Watchdog menu system requests an Engineer's access code: (B,B,B,B). If the correct code is entered then the first parameter (Scale Factor) will be displayed. Sequence through the Setup parameters by touching button C (green). Change values if required by touching buttons A or B and accept by touching button C. At the end of the Setup sequence the option to 'save settings' will be given.

4.4.2 'Factory' Setup

In 'Factory' Setup mode a wider range of parameters can be adjusted and generally through a wider range of values. In addition, the 'Engineer's' access code can be changed in this mode. When 'Factory' setup is selected the Watchdog menu system displays a code number. Take note of this number and contact your Supplier for a special access code. Enter this access code and the Watchdog will go to the 'Factory' setup sequence. Note that it will continue to accept the same access code until 'Yes' response is given to the 'Save settings?' request, after which a new code will be required. At the end of the 'Factory' Setup sequence the option to 'save settings' will be given.

4.5 Engineer adjustable operating parameters

4.5.1 Scale Factor (0.01-99.99) Default setting is "12"

The Watchdog is supplied with the Scale Factor set to 12.00. This value causes the 4 digit numerical display on the front panel to show the measured elevator speed in pulses per minute (PPM) or buckets per minute.

Other units for your installation may be displayed by calculating a new Scale Factor using the following equation:

$$\text{Display} = (\text{Input PPM} \times \text{Scale Factor}) / 12.00$$

$$\text{Therefore: Scale Factor} = (\text{Desired Display} \times 12.00) / \text{Input PPM}$$

The Scale Factor can be altered without affecting the speed calibration or speed trip settings, ie it only changes the numbers which are displayed and not the actual speed.

If at any time the display shows '---', this indicates an overrange condition ie greater than 9999. This usually means that the Scale Factor is incorrectly set.

There are two special cases for setting the Scale Factor which are useful to know.

- (i) With Scale Factor set at 12.00, the display will show the input Pulses per Minute directly.
- (ii) With Scale Factor set to bucket spacing in inches the display will show the belt speed in feet/minute.

Worked Examples of using the Scale Factor:

4.5.1.1 Example 1 - Percentage

If the elevator normal speed is 850 pulses per minute (PPM) and the desired display is 100.0 (%), then Scale Factor = $(100.0 \times 12.00) / 850 = 1.41$

4.5.1.2 Example 2 - Tons/Hour

If the elevator normal speed is 420 pulses per minute (PPM) and the desired display is 3000 TONS/HOUR, then Scale Factor = $(3000 \times 12.00) / 420 = 85.71$

4.5.1.3 Example 3 - Feet/Min

If there are 9 inches between each bucket and you want to display speed in feet/minute then set the Scale Factor to 9.00

4.5.1.4 Example 4 - Meters/Min

Scale Factor = $12.00 \times$ bucket pitch in meters .
Eg. if the pitch is 23cm, (Scale Factor = 12.00×0.23) = 2.76

4.5.1.5 Example 5 - Cubic Meters per Hour

First calculate the normal speed of the elevator in pulses per minute:

If the buckets have 2.9 litres capacity, the speed is 2.5 m/sec and the pitch is 9 per metre, then normal speed is $2.5 \times 60 \times 9 = 1350$ pulses per minute.

The number of cubic metres per hour at this speed is:

$$2.9 \times 2.5 \times 9 \times 3600 \times 0.001 = 235 \text{ m}^3 / \text{hr} \quad \begin{array}{l} (3600 \text{ Seconds in 1 hour}) \\ (1 \text{ litre} = 0.001 \text{ m}^3) \end{array}$$

So we want the display to read 235 at the normal speed, therefore Scale Factor
= $(235 \times 12.00) / 1350$
= 2.09

Now with Scale Factor set to 2.09, the rate of movement of material in cubic metres per hour can be read directly from the Watchdog speed display.

4.5.1.6 Example 6 - Metric Tonnes/Hour

Assuming the same elevator as in the previous example, where the standard speed was calculated at 1350 PPM. If the density is 0.752 tonnes per cubic metre, then the number of Tonnes per Hour at this speed is

$$235 \text{ m}^3 / \text{hr} \times 0.752 = 177 \text{ Tonnes/hour approx.}$$

$$\begin{aligned} \text{We want it to read 177 at the normal speed, so Scale Factor} &= (177 \times 12.00) / 1350 \\ &= 1.57 \end{aligned}$$

4.5.1.7 Example 7 - US Bushels per Hour (BPH)

The Elevator has one row of buckets each with a capacity of 377 cubic inches; at a 6 inch spacing and with a normal running speed of 600 feet/minute.

$$\text{There are } (600 \times 12) / 6 = 1200 \text{ Pulses per Minute}$$

Now, 1 cubic foot = 1728 cubic inches and 1 Bushel = 1.2445 cubic feet so,

the capacity of the elevator is (buckets/min x bucket capacity x minutes/hour) / (1728 x 1.2445)

$$= (1200 \times 377 \times 60) / 2150 = 12622 \text{ BPH}$$

Note that this is outside the range of the available display, so in this case the Scale Factor can be divided by 10 to give a display of BPH x 10

$$\text{Required Scale Factor} = (12622 \times 12.00) / 1200 \times 10 = 12.6$$

4.5.1.8 Example 8 - Cubic Feet per Hour

The Elevator has 2 rows of buckets each with a capacity of 215 cubic inches at 8" spacing and running at 600 feet/second.

$$\text{There are } (660 \times 12) / 8 = 990 \text{ Pulses/minute}$$

$$\text{The capacity of the elevator is } (2 \times 215 \times 990 \times 60) / 1728 = 14781 \text{ cubic feet / hour}$$

$$\text{Again, required Scale Factor} = (14781 \times 12.00) / 990 \times 10 = 17.9$$

Remember that the display will be in $\text{ft}^3 / \text{hour} \times 10$.

4.5.2 Underspeed Alarm (5-20%) Default setting is 10%

When the speed of the elevator falls to this value (calibrated speed - underspeed alarm%) the Alarm lamp will illuminate and the Alarm relay will de-energise.

4.5.3 Underspeed Stop (5-20%) Default setting is 20%

When the speed of the elevator drops to this value [Calibrated speed - Underspeed stop%], the Stop lamp will illuminate and the Stop relay will de-energise.

4.5.4 Overspeed Alarm (5-20%) Default setting is 10%

When the speed of the elevator rises to the value of [Calibrated Speed + 'Overspeed Alarm' %], the Alarm lamp will illuminate. After a delay set by Overspeed Alarm Delay (4.5.16) the Alarm relay will de-energise. This usually indicates wrong calibration (4.3).

4.5.5 Overspeed Stop (5-20%) Default setting is 20%

When the speed of the elevator rises to the value of [Calibrated Speed + 'Overspeed Stop %] the Stop lamp will illuminate. After a delay set by Overspeed Stop Delay (4.5.17) the Stop relay will de-energise. This usually indicates wrong calibration (4.3).

4.5.6 Startup Delay (1-30 seconds) Default setting is 10 seconds

This is the programmed time in seconds within which the elevator should attain full speed following Start.

4.5.7 Number of MAS (1, 2, 3, 4) Default setting is "2"

The number of Motion Alignment Sensors in use on the elevator. (see section 4.8.1)

4.5.8 Misalignment Sensing (Top or Bottom)

When "Number of MAS" is set to 3, the user must select where misalignment is to be measured (top or bottom pair of inputs).

4.5.9 Number of (PTC) HBS zones (0-6)

Default setting is "0" (NTC temperature sensors are standard on new systems)

The number of PTC type (red cable sensors) Hot Bearing Sensor zones in use on the elevator. If used, there must be a PTC sensor fitted and connected for every zone selected, starting at zone 1.

Important Note:

PTC temperature sensors are no longer supplied with new Watchdog systems so this is disabled (set to 0) by default. This value should be non-zero only when using PTC (red cable) temperature sensors.

New systems are supplied with NTC (blue cable) temperature sensors and the NTC menu is programmed for 4 NTC temperature sensors by default. Please refer to the NTC Temperature Section (Section 11) at the end of the manual for information on how to adjust NTC temperature parameters.

4.5.10 Plug Switch, (Yes/No) Default setting is "No"

If this parameter is set to "yes" then a plug switch should be connected to Hot bearing sensor zone 5 (terminal 4E) this should be wired such that in the normal condition the voltage of this terminal is 24V, dropping to 0V when the plug condition occurs

4.5.11 Head Pulley Alignment Sensor (HPAS), (Yes/No) Default setting is "No"

If this parameter is set to "yes" then a Head Pulley Alignment Sensor should be connected to hot bearing sensor zone 6 (terminal 4F) this should be wired such that in the normal condition the voltage at this terminal is 12V, dropping to 0V when the fault condition occurs.

(See data sheet WDD 1.7)

4.5.12 Comms ID (RS422/RS485) (1-32) Default setting is "1"

This is the identification number that will be used by a host computer when communicating with the Watchdog. If more than one unit is connected on a 'multidrop' serial link then they must each have a different value for this parameter. A maximum of 32 Watchdog units may be connected to a multidrop serial link.

4.6 Factory Adjustable Operating Parameters

(To access these parameters, see section 4.4.2.)

4.6.1 Engineer Code

The Engineers Code can be changed for safety/security reasons.

4.6.2 Acceleration Monitoring, (Yes/No) Default setting is "Yes"

This parameter allows Acceleration Monitoring to be "switched off." Whilst disabled in this way, the Watchdog will not respond to any type of underspeed condition during the start-up delay period.

4.6.3 Stop on Hot Bearing, (Yes/No) Default setting is "No"

If enabled, this parameter allows the Watchdog to stop the elevator almost immediately when a hot bearing condition is detected. If disabled the elevator will be stopped after "persistent alarm" seconds.

4.6.4 Type of Thermistor (PTC/NTC) Default setting is "PTC"

Analogue NTC Thermistors can be used to display the individual bearing temperature. (See data sheet WDD 4.6.4)

4.6.5 Speed Range (2000/4000) Default setting is 2000 ppm

For high speed elevators or very closely spaced buckets the speed range can be increased to 4000ppm.

4.6.6 Smoothing Factor (1-32) Default setting is 10

Increasing this parameter improves the Watchdog's immunity to instability of the measured speed and therefore lessens the possibility of false or nuisance alarms and shutdowns. It should be remembered that a high value of Smoothing Factor will tend to reduce the response time of the Watchdog to a sudden change in speed, which may be undesirable. If the elevator has unequally spaced or missing buckets the Smoothing Factor will have to be set to a higher value.

4.6.7 Misalignment Delay (1-30 seconds) Default setting is 6 seconds

This is the time in seconds following misalignment detection that the Alarm Relay will be de-energised. Note that the Alarm Lamp illuminates as soon as a misalignment is detected.

4.6.8 Misalignment Ratio (20-80%) Default setting is 66%

A misalignment condition exists if the speed measured from the probes on one side of the elevator is less than 'Misalignment Ratio' percent of the speed on the other side. Therefore increasing this value increases the magnitude of permissible misalignment.

4.6.9 Persistent Alarm Delay (0.1 - 240 seconds) Default setting is 180 seconds

If any alarm conditions exist, (ie the Alarm Lamp is on) for a period which accumulates to more than the 'Persistent Alarm Delay' seconds, then the Stop relay will be de-energised.

4.6.10 Relay Delay (0.1 - 10 seconds)

This is the time delay in seconds before the Alarm relay de-energises following :-

- (i) detection of a 'hot bearing' condition
- (ii) detection of a 'misalignment' condition.
- (iii) detection of speed less than the 'underspeed alarm' limit

It is also the delay in seconds before the Stop relay de-energises following:-

- (i) detection of speed less than the 'underspeed stop' limit

4.6.11 Overspeed Alarm Delay (1-10 seconds) Default setting is 10 seconds

This is the time delay in seconds before the Alarm relay de-energises following detection of an 'Overspeed alarm condition.'

4.6.12 Overspeed Stop Delay (1 - 30 seconds) Default setting is 20 seconds

This is the time delay in seconds before the Stop relay de-energises following detection of an 'overspeed stop condition.'

4.7 The Test Function

To perform a test, go to the main menu by touching the button "C" (red). Select "TEST" from the main menu. Two options will be displayed, "Test Settings" and "Full Test".

4.7.1 Test Settings

When selected, the test will show the value of the calibrated speed and the actual alarm and stop trip speed settings in pulses per minute on the speed display and the trip percentages on the message display. This test can be performed at any time whether the machine is running or stationary, as the relays do not operate from this test function and the normal running of the machine is unaffected.

4.7.2 Full Test

WARNING: This test will deactivate the alarm and shut down relays which will shut down the elevator. The elevator must be empty and clear of all products when performing this test. When the full test is selected, the engineer's access code will be requested. (see 4.4.1) When the access code is entered, the settings will be displayed as the "Test Settings", and in addition the alarm relay and then the alarm and stop relays will be de-activated, thus verifying the relays and external wiring. It is recommended that these tests are performed on a regular basis in order to verify correct working of the system, the external wiring, and related components. Abort test by touching button "A".

WARNING: A full test should be performed on a regular basis and should be included in the preventative maintenance program for the elevator.

4.8 Normal Operation

4.8.1 Motion Probe connections and Probe Led's

The Watchdog can be used with 1 to 4 motion probes (MAS). The number of MAS is a user selectable parameter in the 'SETUP' sequence. Diagram J shows which terminals are used for the motion probes. Each probe input has a corresponding green LED on the front panel of the Watchdog. The LED will flash when the probe connected to its input detects a bucket or bolt. For clearer indication of pulse consistency the flash rate of the Led's is limited to a maximum of 300PPM (or 5 per second), although the actual input pulse rate can be 4000 PPM.

1 Probe System:

The probe can be connected to any input and the Watchdog will monitor speed only.

2 Probe System:

The probes are connected to the top or bottom pair of inputs. The Watchdog indicates the highest speed measured at the two inputs. Belt misalignment is also detected.

3 Probe System:

The user selects where misalignment is to be measured (top or bottom pair of inputs). The third probe is connected to one of the unused inputs and the Watchdog automatically uses this probe **only** for measuring speed.

4 Probe System:

The probes are connected to all four inputs. Misalignment can be sensed at the top and/or bottom of the elevator. The Watchdog measures the speed at each probe and indicates the highest value found.

Summary of Motion/Misalignment sensing options

TABLE 11

No of MAS	Speed Sensing input	Misalignment Sensing input
0	Inactive	Inactive
1	Upper or Lower L or R	Inactive
2	Upper or Lower L & R	Upper or Lower L&R
3	Upper or Lower L or R	Upper or Lower L&R
4	Upper & Lower L & R	Upper & Lower L&R

4.8.2 Starting and Accelerating

As soon as the motor interlock input is energised to show that the elevator motor has started, the start up timer begins to time out. When this time has expired, the input speed is compared to the Calibrated Speed and if it is within the preset limits, no action is taken.

During start-up conditions the UNDERSPEED detector is inhibited but the ACCELERATION of the elevator leg is monitored to ensure that any belt slip is immediately detected.

The Watchdog uses the system parameter, - 'Start-up Delay' (seconds) to determine the expected speed at any time during the start-up period. If the elevator fails to move at all, or if the speed is less than expected at any time then the Watchdog will trip the STOP and ALARM relays and display 'STARTING FAULT'.

4.8.3 Underspeed Detection

If the belt speed falls below the Underspeed Alarm trip speed, the Alarm lamp will illuminate and a timeout counter will begin counting down from the value of 'Relay Delay' seconds. If the underspeed condition persists when this timer times out then the Alarm relay will de-energise to provide the appropriate warning.

The status message on the display will be 'BELT SLIPPING'. If the speed falls further, below the Underspeed Stop trip speed, the Stop lamp will illuminate; a timer will begin a countdown from 'Relay Delay' seconds; and again, if the underspeed condition persists when the timer times out then the Stop relay will de-energise to stop the motor.

Note that until the Stop relay has been de-energised, the system can recover from under-speeding conditions if the speed returns to a higher value.

When the motor stops the display will show 'STOP CONDITION' and 'UNDERSPEED FAULT' and the Stop lamp will remain lit

4.8.4 Overspeed Detection

The Watchdog overspeed function informs operators of an incorrectly calibrated unit. This could happen if a unit is calibrated whilst the belt is slipping.

When the belt speed rises above the Overspeed Alarm trip speed the Alarm lamp will illuminate; the Overspeed Alarm Delay timer will begin counting down and the status messages will reflect this. If the overspeed condition persists when the timer times out the Alarm relay de-energises, and the status message will be 'OVERCALIBRATION'.

If there is a further increase of speed to a level above the Overspeed Stop level then the Stop lamp will illuminate; the Overspeed Stop Delay timer will begin counting down; and the status message will show the timer value. If the Overspeed stop condition persists when the timer times out then the Stop relay will de-energise to stop the motor.

Note that until the Stop relay has been de-energised, the system can recover from over-speeding conditions if the speed returns to a lower value.

When the motor stops the display will show 'STOP CONDITION' and 'OVERCALIBRATION' and the Stop lamp will remain lit.

4.8.5 Misalignment Detection

The Watchdog senses misalignment conditions from a pair of motion probe inputs. In a system with two probes, either the upper or the lower inputs are used for sensing misalignment. In a four probe system the unit senses misalignment from both the upper and lower pair of probe inputs.

If the input signal rate from one of the probes should cease (or fall to less than 'Misalignment Ratio' percent of the rate of the other probe) this is treated as a mis-alignment condition. If this condition persists for more than about 2 seconds, the Alarm lamp will illuminate and a timer will begin counting down from 'Misalignment Delay' seconds. the display will show "MISALIGNMENT" and the location "TOP" or "BOTTOM". If the misalignment condition persists when the timer times out the Alarm relay will de-energise to provide the appropriate warning. The misalignment condition will also be indicated by the display. If the misalignment condition ceases the Alarm relay will energise and the Alarm lamp will be extinguished.

4.8.6 Bearing Over-Temperature Detection

Bearing temperature sensing is selected by setting the system parameter, - 'No of HBS zones' to a value between 1 and 6. A bearing sensor must be fitted for each of the zones selected and connected to the relevant HBS zone inputs on the Watchdog. If 'No of HBS zones' is set to zero then hot bearing sensing is inactive. If the temperature of a bearing sensor connected to one of the selected zones rises above its trip point, the Alarm lamp will illuminate. If this condition persists for more than about 2 seconds the Alarm relay will de-energise to provide the appropriate warning. If a hot bearing condition persists, the display will show 'HOT BEARING ZONE x'.

4.8.7 Persistent Alarm Conditions

If the Alarm lamp is illuminated because of UNDERSPEED, OVERSPEED, MISALIGNMENT or HOT BEARING conditions, and the condition has persisted for more than 'Persistent Alarm Trip' minutes, then the Stop lamp will illuminate and the Stop relay will de-energise to stop the elevator motor. If the alarm condition persists for less than 'Persistent Alarm Trip' minutes and is then cleared, the amount of alarm elapsed time is stored in memory. This elapsed time is cancelled after an equal time without any alarm condition. Consequently, if the alarm condition is intermittent, but no single interval of alarm exceeds persistent alarm trip, the persistence of the alarm can eventually result in a STOP condition.

If this happens, the display will show 'STOP CONDITION' PERSISTENT ALARM, (see section 4.8.8).

The following example will serve to illustrate this useful function as it shows how a STOP condition can be caused by a number of Alarm conditions existing over a period of time..

Example: 'Persistent Alarm Trip' is set to 3 minutes (see section 4.6.9) :-

Condition	Elapsed time	
Underspeed Alarm for 2 minutes	2 Mins	
No alarm for 0.5 minutes	1.5 Mins	
Misalignment Alarm for 1 minute	2.5 Mins	No
alarm for 1 minute	1.5 Mins	
Misalignment and Hot Bearing for 1.5 minutes	3 minutes	
	STOP!	

NOTE:

A SHUTDOWN will stop the elevator motor dependent upon the interlocking stopping circuit. When the motor is restarted, the Alarm elapsed time is cancelled.

Short persistent alarm conditions will cause the relevant lamp to flicker on and off without de-energising the Alarm or Stop relays. This can serve as a warning that elevator maintenance may be required.

4.8.8 Stop (Shutdown) Conditions

When the Watchdog is in a 'Stop' condition, the Relays are de-energised and the Stop lamp is illuminated. The alarm lamp will also be illuminated if a HOT BEARING condition persists. A status message will be indicated on the display which consists of 'STOP CONDITION' on the upper line and the following text on the lower line:-

Status	Description
STARTING FAULT	Elevator belt failed to maintain acceleration during start up or failed to move at all. Check that the system parameter,- 'Start-up Delay' is long enough and that there are no blockages in the elevator leg before attempting a re-start.
OVERCALIBRATION FAULT	i.) Speed exceeded 'Overspeed Stop' percentage increase on Calibrated speed for a duration longer than the 'Overspeed Stop Delay' seconds. ii.) Persistent 'Overspeeding' above Alarm percentage has occurred.
UNDERSPEED FAULT	i.) Speed was less than 'Underspeed Stop' percentage decrease on Calibrated speed (for a duration longer than 'Relay Delay' seconds.) ii.) Persistent ' Belt Slipping' has occurred, (speed is less than the underspeed alarm level). iii.) Check belt tension and recalibrate while the elevator is running empty.
PERSISTENT ALARM	Alarm conditions have accumulated for more than a duration set by 'Persistent Alarm Time' seconds. Can be caused by any combination of Over/Underspeed, Misalignment, Hot bearing, Plug Condition and Head Pulley Alignment alarm conditions.

If more than one condition caused the STOP, the status messages will be indicated in sequence.

4.8.9 Power-fail Conditions

If the power supply to the Watchdog is removed, the Stop and Alarm relays will de-energise. The Calibrated Speed and the setup parameters remain stored in memory.

5 QUICK CHECKLIST

For problems after initial start-up

1. Are all the buckets in the elevator ferrous (steel) or non-ferrous (plastic, urethans or stainless steel)? If magnetic, ie steel, the motion probe should be directed at the bucket as in drawings 'B' and 'C'. If non-magnetic, the motion probe should be directed at the steel bolt heads as drawings 'D' and 'E'.
2. Are all the buckets present on the belt (none missing) and equally spaced?
3. Is there excessive interference on the electrical power supply? Power conditioners and surge (spike) suppressor may have to be fitted.
4. Is the motor interlock wired correctly and is the correct interlock voltage present when the motor is running? (Terminals 6 & 7)
5. Has the Watchdog been calibrated?
6. Has the wiring for the probes been routed away from power cables? See paragraph 2.2. & 2.3.
7. Are the probes mounted away from plastic abrasion liners (which could cause static interference), electric motors and other magnetic fields?
8. Is the Watchdog circuit properly grounded?
9. Is the elevator leg grounded to prevent static build-up?
10. Is the belt in good condition and running true?
11. Does the belt stay in alignment when material is fed into the elevator leg?
12. Is the elevator leg belt tensioned sufficiently to prevent belt slip?
13. Check that there is no tramp metal in the intake, no loose head pulley lagging, and no loose abrasion liners.
14. Have the probes been mounted properly, rigidly and free from vibration?
15. Check that the probes do not come in contact with the buckets or the bolts.
16. If sensing on the bolt heads, are the probes positioned on the outside of the bolt heads as drawing 'D' and 'E'?
17. Is the Micro-processor control unit overheating, if so mount in temperature-controlled environment of maximum ambient temperature 104°F (40°C).
18. If the elevator bucket bolts are non ferrous (stainless steel), insert mild steel fender washers between the belt and buckets as targets.
19. Check that high powered 'Walkie Talkie' radios are not operated near the Watchdog control unit or probes, as this may affect the performance.
20. If your bucket elevator has a weighted take up please contact '4B' to ensure sufficient weight is placed upon it (especially when changing from steel to plastic buckets).
21. If the "Watchdog" is used in conjunction with a PLC (programmable logic controller) it is possible for a residual voltage to appear across terminals 6 and 7. Contact '4B' if this occurs.
22. If after 5 seconds, the Watchdog display fails to power-up, then check the supply voltage and external fuse.

6 FAULT FINDING CHART

	SYMPTOM	CAUSE	REMEDIAL ACTION
1	LED on Motion Probe	Probe too far away from buckets Probe adjustment incorrect Wiring connection faulty	Move probe closer to bucket if possible does not flash Turn screw clockwise to increase sensitivity Check wiring
2	LED on motion probe excessively	Probe too close to buckets Probe adjustment incorrect Interference in wiring Probes require adjustment	Move probe away from buckets flashes Turn screw counter-clockwise Use shielded cable and rigid conduit See Section 1.2
3	Probe LED on Control unit does not flash	Elevator is not running. Motion probe not operating. Wiring Fault. Probes connected to wrong terminals.	See section 1 above and Table 4 Check wiring
4	Wrong probe LED on unit flashes	Motion probe connected to wrong input.	See Section 4.8.1
5	Alarm LED on	Hot Bearing Belt Misaligned Belt Slipping Overspeeding Alarm trip settings incorrect	Check all bearings Check belt Check belt, tension Check calibration Refer to section 4.4 (setup procedure)
6	Stop LED on	Stop condition occurred settings incorrect	See section 4.7.8 (Stop conditions) Stop trip Refer to section 4.4 (setup procedure)
7	Speed display unstable	Probe adjustment required Missing buckets/bolts	See 1 & 2 above Replace
8	Speed display is ' - - - '	Overrange ie greater than 9999	Set Scale Factor (section 4.5.1)
9	Speed display incorrect	Scale factor incorrectly set	Set Scale Factor (section 4.5.1)
10	Elevator fails to start	Interlock faulty. Interlock supply remains on following Stop condition Watchdog unit not powered up.	Check wiring Press Stop button then Start button Power up Watchdog
11	Elevator starts but fails to keep running.	Start-up time too short Incorrect calibration. Motion probe not adjusted. Belt slipping	Increase Start up Delay (section 4.5.6) Check belt speed & re-calibrate See 1 & 2 above Check belt speed & re-calibrate
12	Alarm relay pulsing & Alarm lamp flashing	Watchdog uncalibrated or waiting to start calibration	See section 4.1 on Calibration procedure
13	Power on, but not work	Microprocessor may be in wait condition. Fuse Blown	Switch off power for a short unit does time then switch on Check Wiring and fuse
14	Calibration fails	Motor failed to start Speed exceeded 2000 PPM with speed range set to 2000	Check connections to motor Check for blockages in elevator Check required speed range

7. WARNING MESSAGES DISPLAYED ON LCD

TEXT ON LCD	CAUSE	ACTION (where required)
'Not Calibrated'	Watchdog Not calibrated	Calibrate (Section 4.1 – Page 26)
Start Elevator Calibrate	Calibrate option has been selected from menu	Start Elevator to
Hot Bearing	Bearing at Zone x has exceeded temperature	Check the bearing at Zone X Zone x Check wiring for fault
HBS open circuit Zone x	Bearing sensor faulty or wiring faulty	Check bearing sensor & wiring at Zone x
Misalignment Upper/Lower	Belt is misaligned at top or bottom	Check elevator belt Check MAS (Section 6 – Page 37)
Underspeed Alarm Delay in seconds Slipping'	Elevator belt is slipping Incorrect calibration	Check the belt tension Check the belt speed and re-calibrate or 'Belt
Overspeed Alarm Delay in seconds or Overspeeding	Incorrect Calibration	Check the belt speed and re-calibrate
Plug Condition Pulley Misalignment Denied Manual !	Spout is Plugged Head Pulley is Misaligned Wrong Setup access code was entered. Wrong Calibration access code was entered.	Check for blockage in spout Head Check head pulley alignment Access Try again or consult supplier See
Internal Fault Code n	Watchdog internal fault	Contact supplier
Power_Fail	Supply voltage out of limits	Check supply voltage See Table 1 - Electrical ratings
MAS Fault /Lower	Mains Interference on MAS Probe signals. Cal speed is more than 2000PPM and Speed Range = 2000.	Use shielded cable & Upper rigid conduit Set Speed Range to 4000
Stop Condition Fault	Elevator failed to accelerate	Check elevator leg. Starting Check motor starting circuitry Check condition of "soft start" system
Stop Condition Underspeed Fault	Elevator speed was below preset value	Check belt tension Check belt speed
Stop Condition Overcalibration Fault	Elevator speed was above preset value	Check belt tension Check belt speed and recalibrate
Stop Condition Persistent Alarm	One or more alarm conditions have persisted	Check and remedy problem.
Stop Relay Open Speed n	Waiting for motor to stop	None
Motor Running Speed n	Normal Running	None

Note: In all cases, immediately stop the elevator before investigating any problem. Ensures that all lock-out and tag-out procedures are adhered to.

8 LIABILITY AND INDEMNITY

- 1) In respect of installation or applications of the goods as parts or components of other goods or machinery the buyer shall be solely responsible for the compliance and the installation with safety regulations issued by competent authorities and in force at the place of operation and / or for its compliance with any terms of insurance notified by the Buyer's insurance for personal injury or damage to property or loss of profit through fire, explosion, gas or otherwise.
- 2) Neither the Company nor its suppliers shall in any circumstances whatsoever be liable for any loss or damage suffered by the Buyer or by any third party howsoever caused involving any person, property or interest, suffered by the Buyer or any third party directly or indirectly in connection with the use, functioning or state of the goods, unless the same shall arise out of the Company's negligence.
- 3) The Buyer shall indemnify the Company against all actions, claims or demands by third parties, whether in tort or otherwise, howsoever arising, directly or indirectly, in connection with the use, functioning or state of the goods or in connection with the performance of service.

Limitation of Liability

Without prejudice to the foregoing, the Company shall in no circumstances be liable:-

- 1) For any incidental or consequential loss or damage suffered by the buyer, including, with out limitation, delay, detention, loss of production, loss of profit or liability to third parties except liability for personal injury or death arising out of negligence by the Company.
- 2) For any loss or damage covered by insurance or which would ordinarily be covered by insurance.

Warranty

The equipment is covered by 24 months warranty from the date of despatch. Any faults arising due to faulty materials or workmanship in the original equipment within the warranty period will be corrected free of charge providing the equipment is returned to us freight paid.

Watchdog Elite - M/A PROBE MOUNTING BLOCK

Photocopy this template and use for marking out holes for the mounting blocks.

The mounting block is made from 1" thick high-density polyethylene and is supplied with a 1/4" x 4 1/2" long zinc-plated clamping bolt and lock nut

PLEASE REFER TO THE TEMPLATE ADDENDUM FOR THE MOUNTING TEMPLATE

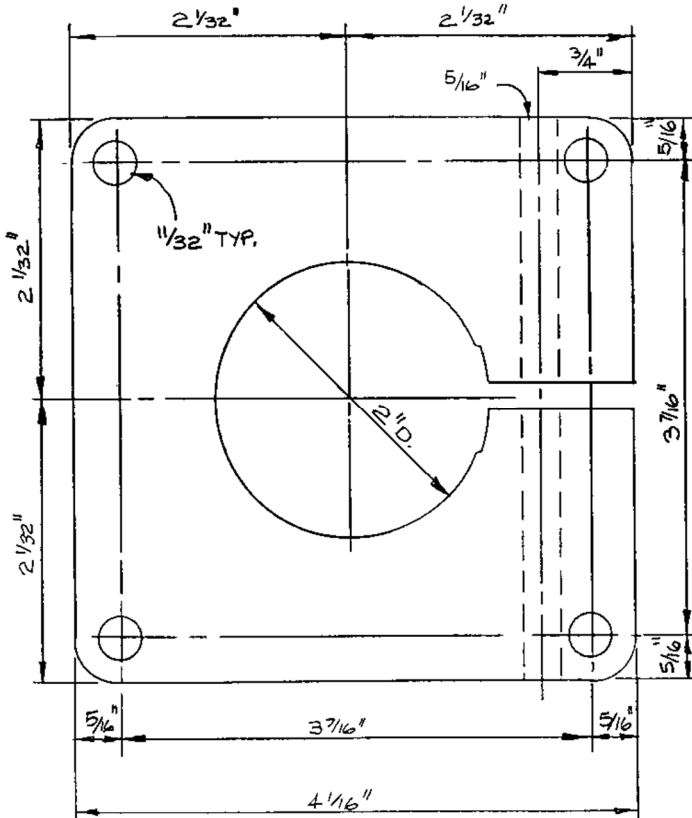

**NOT TO SCALE
PLEASE USE SEPARATE TEMPLATE**

Certification Markings:

V46

CE 1180 Ex II 3D Ex tc IIIC T125°Dc IP66 T_{AMB}-20°C to +45°C Baseefa II ATEX 0033X
Ex tc IIIC T125°Dc IP66 T_{AMB}-20°C to +45°C IECEx BAS11.0018X



CLII DIV2 Groups F & G
Ex tc IIIC T125°C Dc IP66 Tamb -20°C to +45°C
Zone 22 AEx tc IIIC T125°C Dc IP66 Tamb -20°C to +45°C

V4

CE 1180 Ex II 2D Ex tb IIIC T125° Db IP66 T_{AMB}-20°C to +50°C Baseefa04ATEX0131X
Ex tb IIIC T125° Db IP66 T_{AMB}-20°C to +50°C IECEx BAS05.0026X



CLII DIV1 Groups E,F & G (When used with a Class2 power supply)
Ex tb IIIC T125°C Db IP66 Tamb -20°C to +50°C
Zone 21 AEx tb IIIC T125°C Db IP66 Tamb -20°C to +50°C

ATEX Power Rating:

ATEX category 2D, IECEx category A21: 12 Watts

ATEX category 3D, IECEx category A22: 25 Watts

CSA Power Rating:

12 Watts

Special conditions of use:

1. **The equipment shall be suitably earth bonded via the PCB mounted earth terminal inside the equipment enclosure.**
2. **Warning: The equipment is a potential static hazard, clean only with a damp cloth.**
3. **Do not allow dust layers to build up on the equipment.**

To Open the Lid:

1. Disconnect power (isolate ALL circuits)
2. Untighten the lid securing screws
3. Carefully open the lid ensuring that the gasket is not damaged and remains in place

To Close the Lid:

1. Check that the gasket is correctly fitted into the box groove and is undamaged.
2. Tighten the lid screws.
3. Check that the lid and box are correctly mated.

Enclosure Installation:

- a. The IP66 rating of the enclosure must be maintained when used in Zone 21 dust environment. You must use the correct cable, glands and sealing arrangement and in accordance with the installation codes detailed in the appropriate standards.
- b. Where other certified components are used as part of the assembly or installation procedure, the user must take in to account any limitations which might be listed on the relevant certificates.
- c. The box is supplied with 2 pre drilled holes in the bottom face. All unused entry apertures must be sealed using component certified stopping plugs as recommended under the standard. The end user must install component or apparatus certified stopping plugs and cable glands in strict accordance with the manufacturer's instructions.
- d. The enclosure must not be modified in any way without reference to the manufacturer, as this will invalidate the certification.
- e. All wiring must be carried out in accordance with relevant national electrical codes or instructions (BS EN 600079-14, EN50281).
- f. The voltage and current and maximum power dissipation shown on the box label must not be exceeded.
- g. The wiring insulation must extend to within 1 mm of the metal face of the terminal.
- h. All leads must be insulated for the appropriate voltage.
- i. Not more than 1 single or multiple strand cable is to be connected to any terminal unless multiple conductors have previously been joined in a suitable manner (e.g. boot lace ferrule) such that they present a single connection point to the terminal.
- j. A parallel shaft screwdriver of the correct size should always be used when tightening terminals.

11 Using NTC bearing sensors with the Watchdog.

The NTC bearing sensor monitor and alarm section provides the end user with the ability to set, monitor and react to between 0 and 6 NTC bearing sensors. The temperature of each sensor can be individually and continuously displayed. A menu system allows you to select how many sensors to use, their trip temperatures and whether to operate in °C or °F. The data can be modified using the Watchdog keypad and is stored within the Watchdog.

BASIC SPECIFICATION:

- Can accommodate between 0 and 6 WDB10V3CAI/WDB20V3CAI series NTC bearing sensors
- The sensors are connected to the Watchdog through the normal temperature sensor connections
- The Watchdog can display temperatures between -20°C (-4°F) and 110°C (230°F)
- Temperature accuracy +/- 1°C (2°F) display in whole numbers only
- Temperature alarms can be individually set for each sensor in the range of 10°C (50°F) to 110°C (230°F)
- The temperatures are calculated as an average reading over 5 seconds
- Three alarms are generated, over temperature, open circuit sensor, and short circuit sensor.
- The alarm relay will operate 10 seconds (default) after any detected alarm (see page 44)
- The stop relay will operate between 180 and 1 second after the detected alarm (persistent alarm detection) unless immediate stop on HOT bearing has been set
- Alarms remain on the display until the fault/over temperature problem is removed.
- Fail safe operation
- The temperature data can be read through the Watchdog's serial port

OPERATION:

NOTE: The Watchdog cannot be configured to use both PTC and NTC sensors simultaneously.

To use PTC sensor you must set the number of NTC sensors to 0 and conversely, to use NTC sensors, you must set the number of PTC sensors to 0. Setting both to 0 will effectively disable the temperature alarm monitoring. Setting both to a number other than 0 will result in one or more temperature alarms. To use head pulley alignment and blocked chute sensors on the Watchdog, you may only programme up to 4 NTC sensors (1-4).

At power up the display
Will show the NTC software
Version. Followed by the usual
Watchdog greeting screens and software version.

```
Diagnosics 5
NTC V1.2.7 E
```

When the Watchdog powers up it will operate in the normal mode. If NTC sensors have been programmed, then the temperatures will be monitored. If an alarm condition occurs, then the display will automatically switch to the temperature display mode. If the operator wishes to see the current temperatures whilst in the normal Watchdog mode, then touch the 'A' and 'C' key both at the same time. This will then switch the Watchdog into the NTC display mode. In this mode the Watchdog will continue to operate normally.

Typical Watchdog display

```
ELEVATOR RUNNING
SPEED 100 %
```

Touch buttons 'A' and 'C' at the same time

No Temperatures
to display

After 5 seconds, the display will automatically enter the menu mode

MENU SELECTION
A=WD B=NTC C=NON

Touching button 'A' will return you back to the main Watchdog menu, button 'B' sends you to the NTC setup menu, and button 'C' sends you back to the NORMAL NTC display (if the NTC hasn't yet been configured then this will return you to the "No Temperatures to display" message on the display).

Touch button 'B' the begin entering the NTC sensor information

ENGINEER'S CODE?

You will be prompted to enter the engineers code (BBBB)

If you enter an incorrect code you will see..

ACCESS DENIED
. .SEE MANUAL!

If you enter the correct engineering code the display shows..

Number of NTC
Sensors 0 °C

Use the 'A' (up) and 'B' (down) key to add or subtract from the total number of NTC sensors connected to the Watchdog

Number of NTC
Sensors 4 °C

Touching the 'C' will move you on to the next entry area. Now chose the temperature type, key 'A' selects °C and key 'B' selects °F. **All** sensors use the same setting.

Number of NTC
Sensors 4 °C

Now we have to set the alarm levels for the selected sensors so touch 'C' to move on to the next screen

NTC Sensor 1
Alarm = 080 °C

Use the 'A' (up) and the 'B' (down) 'keys to add to or subtract from the alarm value. Each single press changes the value by 1 and if you hold your finger on the key the value will change at a faster rate. When

you have finished changing the value, touch key 'C' to move on to the next alarm. Continue doing this until you have entered an alarm value for each selected NTC sensor.

NTC Sensor 2 Alarm = <u>070</u> °C	NTC Sensor 3 Alarm = <u>080</u> °C	NTC Sensor 4 Alarm = <u>075</u> °C
---------------------------------------	---------------------------------------	---------------------------------------

If you do not wish to change an existing alarm value, just touch the 'C' key to move on to the next value.

Once you have entered all the data for the sensors you have a choice of stopping the elevator after a 180 second delay when a HOT bearing is detected or stopping the elevator immediately when a HOT bearing is detected.

Immediate STOP on HOT bearing: NO

Touching the 'A' key will set the immediate stop to 'NO' touching the 'B' key will set the stop to 'YES'. The default setting is 'NO'.

When a temperature alarm is detected the Watchdog will turn on the alarm LED immediately. After a short delay (the default is 10 seconds) the alarm relay will operate sounding any external alarm that may be fitted. Using the next menu option you can adjust the delay time between detecting the temperature alarm and the alarm relay being activated.

Alarm delay is Currently <u>10</u> sec

Touching the 'A' key will increment the time in intervals of 1 second and if you hold your finger on the key the value will change at a faster rate. The maximum alarm delay period is 60 seconds

Touching the 'B' key will decrement the time in intervals of 1 second and if you hold your finger on the key the value will change at a faster rate. The minimum alarm delay period is 0 seconds

When you have completed entering all of the values, the display changes to ..

Save Changes? A=NO - C=YES

Touching key 'A' throws away all the changes and reloads the old values again.

Touching key 'C' will save the new values in to the permanent memory on the Watchdog and will be reused every time you power up the Watchdog.

Saving.

Once the data has been saved you will be returned back to the NTC temperature display.

If whilst in the menu you do not touch a button for 30 seconds, the menu will be closed and any new data will be lost.

NTC TEMPERATURE DISPLAY:

You reach this display information in one of the following three ways. Touching the 'A' and 'C' key together when you are viewing the normal Watchdog information; touching the 'C' key when in the menu selection mode, or after saving sensor edits.

The normal NTC temperature display looks like this...

Sensor #1 of 4 NTC Temp = ###°F

The value in ### will be the actual temperature measured in either °C or °F depending upon your settings. Touch the 'A' or 'B' keys to move up or down through the list of sensors.

Sensor #2 of 4 NTC Temp = 046°C	Sensor #3 of 4 NTC Temp = 039°C	Sensor #4 of 4 NTC Temp = 048°C
------------------------------------	------------------------------------	------------------------------------

You can only view the temperatures for the number or programmed sensors.

If a sensor generates an alarm then the display will look like this ..

Sensor #1 of 4 NTC Temp = <OVR>

Indicates that sensor 1 is currently over range (probably short circuit)

Sensor #1 of 4 NTC Temp = <OPN>

Indicates that sensor 1 is open circuit

If the temperature has exceeded the set alarm level then the following will be displayed.

The actual temperature

Sensor #1 of 4 NTC Temp = 083°C

Followed by a high temperature
Warning

NTC Sensor 1 HIGH TEMP ALARM

Followed by a
Persistent alarm

Persistent Alarm STOP IN 180 Sec

The three display images will cycle every 3 seconds until the alarm condition is removed. The persistent alarm time will reduce by 1 every second until it reaches 0, at which point it will stop the machine by operating the stop relay. If you chose *immediate stop on hot bearing* (see page 44) then there will be no delay between the alarm detection and the stop.

NTC TEMP. ALARM MACHINE STOPPED

The persistent alarm operates in an identical manner to that described in the Watchdog manual section 4.8.7. Although identical in manner, the persistent alarm is independent of the Watchdogs own persistent alarm cycle.

OTHER ALARMS:

As mentioned earlier, the NTC sensors are monitored for HIGH TEMPERATURE alarms, OPEN CIRCUIT, and OVER RANGE (short circuit) alarms. The alarms are presented on the display in the same way as any other alarm.

Sensor #1 of 4 NTC Temp = <OPN>	Sensor #1 of 4 NTC Temp = <OVR>
NTC Sensor 1 OPEN CIRCUIT!	NTC Sensor 1 OVER RANGE! ERR
Persistent Alarm STOP IN 095 Sec	

ALARM PRIORITIES:

The NTC version of the Watchdog operates in two independent and completely separate modes. The Watchdog mode, providing all of the original functionality, and the NTC mode which is responsible for monitoring and responding to variable temperatures.

If the Watchdog is displaying information relating to the elevator functions and a temperature alarm occurs, the display will automatically switch to show the temperature alarm conditions. If the Watchdog is displaying information relating to the temperature sensors and an elevator alarm occurs, then the display will switch to the elevator alarm.

If both elevator and temperature alarms occur together, the Watchdog elevator alarm will take priority. When this alarm has been removed, the temperature alarm will appear on the display.

REFERENCE INFORMATION:

When increasing the number of sensors in use say from 4 to 6 sensors then the two new sensors may initially cause a very brief 'open circuit' alarm. This is because the temperature values are averaged over a period of 5 seconds and when new sensors are first introduced the average temperature is negative. This negative average is seen as an open circuit. The problem will correct almost immediately unless the sensor is in fact open circuit in which case the alarm will remain in place.

The alarm value can only be positive numbers, negative temperatures are measured but you cannot enter negative alarm values.

The NTC persistent alarm timer is independent of the Watchdog's persistent alarm timer.

The alarm relay activation delay timer has a factory default of 10 seconds following alarm detection. This value may be adjusted between 0 and 60 seconds (see P44)

The persistent alarm timer is preset to 180 seconds and cannot be changed.

To use head pulley alignment and blocked chute sensors on the Watchdog, you may only programme up to 4 NTC sensors (1-4).

If you are displaying the temperature detail and a Watchdog alarm occurs then the software will automatically switch back to the Watchdog display.

If the Watchdog alarm and NTC alarm occurs at exactly the same time, the display will flick from one alarm to the other for a few seconds until the alarm priority works out what to do and then the Watchdog alarm is given highest priority.

WARRANTY INFORMATION

1. EXCLUSIVE WRITTEN LIMITED WARRANTY

ALL PRODUCTS SOLD ARE WARRANTED BY THE COMPANY (4B COMPONENTS LIMITED, (4B) BRAIME ELEVATOR COMPONENTS LIMITED, AND (4B) S.E.T.E.M. Srl) HEREIN AFTER REFERRED TO AS 4B TO THE ORIGINAL PURCHASER AGAINST DEFECTS IN WORKMANSHIP OR MATERIALS UNDER NORMAL USE FOR ONE (1) YEAR AFTER DATE OF PURCHASE FROM 4B. ANY PRODUCT DETERMINED BY 4B AT ITS SOLE DISCRETION TO BE DEFECTIVE IN MATERIAL OR WORKMANSHIP AND RETURNED TO A 4B BRANCH OR AUTHORIZED SERVICE LOCATION, AS 4B DESIGNATES, SHIPPING COSTS PREPAID, WILL BE, AS THE EXCLUSIVE REMEDY, REPAIRED OR REPLACED AT 4B'S OPTION.

2. DISCLAIMER OF IMPLIED WARRANTY

NO WARRANTY OR AFFIRMATION OF FACT, EXPRESSED OR IMPLIED, OTHER THAN AS SET FORTH IN THE EXCLUSIVE WRITTEN LIMITED WARRANTY STATEMENT ABOVE IS MADE OR AUTHORIZED BY 4B. 4B SPECIFICALLY DISCLAIMS ANY LIABILITY FOR PRODUCT DEFECT CLAIMS THAT ARE DUE TO PRODUCT MISUSE, ABUSE OR MISAPPLICATIONS, AS AUTHORIZED BY LAW, 4B SPECIFICALLY DISCLAIMS ALL WARRANTIES THAT THE PRODUCT IS FIT OR MERCHANTABLE FOR A PARTICULAR PURPOSE.

3. NO WARRANTY "BY SAMPLE OR EXAMPLE"

ALTHOUGH 4B HAS USED REASONABLE EFFORTS TO ACCURATELY ILLUSTRATE AND DESCRIBE THE PRODUCTS IN ITS CATALOGS, LITERATURE, AND WEBSITES, SUCH ILLUSTRATIONS AND DESCRIPTIONS ARE FOR THE SOLE PURPOSE OF PRODUCT IDENTIFICATION AND DO NOT EXPRESS OR IMPLY A WARRANTY AFFIRMATION OF FACT, OF ANY KIND OR A WARRANTY OR AFFIRMATION OF FACT THAT THE PRODUCTS WILL CONFORM TO THEIR RESPECTIVE ILLUSTRATIONS OR DESCRIPTIONS. 4B EXPRESSLY DISCLAIMS ANY WARRANTY OR AFFIRMATION OF FACT, EXPRESSED OR IMPLIED, OTHER THAN AS SET FORTH IN THE EXCLUSIVE WRITTEN LIMITED WARRANTY STATEMENT ABOVE, INCLUDING, WITHOUT LIMITATION, THE IMPLIED WARRANTIES OF MERCHANTABILITY AND FITNESS FOR A PARTICULAR PURPOSE.

4. LIMITATION OF DAMAGES

ANY LIABILITY FOR CONSEQUENTIAL, INCIDENTAL, SPECIAL, EXEMPLARY, OR PUNITIVE DAMAGES, OR FOR LOSS OF PROFIT WHETHER DIRECT OR INDIRECT, IS EXPRESSLY DISCLAIMED.

Document Revision	Date revised	Revisions made
1.63(R1)	Sept /09	Added revised legal and warranty information to the manual Revised the layout of the first few pages to improve appearance
1.63(R2)	Feb 2010	Added revised legal and warranty information. Removed error in markings WDC3NV46CAI should have been WDC3NV46A
1.63(R3)	Mar 2010	Adjusted the power diagrams to remove any conflict with model types in zone 21 & 22
R4	Feb 2011	Certification code change (V46A,V46AI) updated all certification codes.
R5	May 2011	Removal of D of C (now supplied separately)
R6	July 2011	Changed Certification to include CSA.
R7	Nov 2011	Technical amendments.
R8	July 2013	Updated certification coding.
R9	January 2015	Updated pg22 and 23 to indicate V4orV46 modified 4.5.9. Pg41 Explicit conditions of Use.