



F500 Elite.

FIELDBUS ADAPTER.

**Watchdog NTC Elite to
Ethernet/Modbus TCP
communications.
(Software Version 9.5.x)**

Document Revision List

Initial Revision 0 – July 2014 (created using Watchdog NTC to F500 with Ethernet interface REV3 - which is a CSA only manual)

CONTENTS

INTRODUCTION

- 1 SPECIFICATIONS**
- 2 INSTALLATION INSTRUCTIONS**
- 3 ELECTRICAL WIRING**
- 4 OPERATING INSTRUCTIONS**

FAULT FINDING

CONTACT INFORMATION

DRAWINGS

- A CONNECTING THE F500 ELITE TO AN AC SUPPLY**
- B CONNECTING THE F500 ELITE TO A DC SUPPLY**
- C F500 ELITE TO WATCHDOG ELITE CONNECTIONS**
- D F500 ELITE TO VT100 SERIAL TERMINAL CONNECTIONS**
- E GENERAL CONNECTION DETAIL**

APPENDIX A – SETTING THE MODULE SWITCHES

APPENDIX B – CHANGING THE DEFAULT IP ADDRESS

F500 FIELDBUS ADAPTER.

INTRODUCTION

This version of the F500 Elite Fieldbus adapter had been designed to work as a Watchdog Elite communications gateway and has been designed specifically to allow up to 10 Watchdog control units to be networked together through their own built in communications system. The network data can then be passed through the Fieldbus adapter to an Ethernet or Modbus TCP network. The communications control unit is housed in a self-contained wall-mounting enclosure, and will operate from 100-240v AC or from 24v DC.

1. SPECIFICATIONS

1.1 The Control Unit

A plastic enclosure houses the electronics and terminal connectors. The unit contains a printed circuit board to accommodate power supply circuitry, microprocessor, Fieldbus card and terminals. The design is capable of accommodating 8 of the most common Fieldbus interfaces.

Electrical Supply	-	100-240VAC +/- 10% 50/60Hz
	-	24VDC +/- 10%
Power Consumption	-	12 WATTS
Terminals	-	Power 4mm ² 14 AWG max
	-	Communications, as appropriate to the Fieldbus module.
Protection	-	NEMA4X,IP66
Height	-	9.7", 246mm
Width	-	7.4", 188mm
Depth	-	4", 102mm
Fixing Centres	-	8.75" high x 4" wide, 222mm x 102mm
Cable Entry	-	2 Holes 1 1/8" DIA, 28mm, 3/4" CONDUIT
Weight	-	3lbs, 1.3Kg

Approvals

For V4 Model

CE 1180 Ex tb IIIC T125° Db IP66 T_{AMB} -20°C to +50°C IECEx BAS05.0026X

CE 1180 Ex II 2D Ex tb IIIC T125° Db IP66 T_{AMB} -20°C to +50°C Baseefa04ATEX0131X

CSA - Class II Div. 1, Groups E, F & G
(T4004V4CAI - When Powered with a Class 2 Power Supply)

For V46 Model:

CE 1180 Ex tc IIIC T125° Dc IP66 T_{AMB} -20°C to +45°C IECEx BAS11.0018X

CE 1180 Ex II 3D Ex tc IIIC T125° Dc IP66 T_{AMB} -20°C to +45°C Baseefa11ATEX 0033X

CSA - Class II Div. 2, Groups F & G (F5004V46CAI-ETH)

Power Dissipation in Watts

ATEX category 2D: 12 Watts

ATEX category 3D: 25 Watts

CSA (F5004NV4CAI-ETH): 12 Watts

CSA (F5004NV46CAI-ETH): 12 Watts

Approval Safety Information

To Open the Lid:

1. Disconnect power (isolate ALL circuits)
2. Untighten the lid securing screws
3. Carefully open the lid ensuring that the gasket is not damaged and remains in place

To Close the Lid:

1. Check that the gasket is correctly fitted into the box groove and is undamaged.
2. Tighten the lid screws.
3. Check that the lid and box are correctly mated.

Special conditions of use:

1. **The equipment shall be suitably earth bonded via the PCB mounted earth terminal inside the equipment enclosure.**
2. **Warning: The equipment is a potential static hazard, clean only with a damp cloth.**
3. **Do not allow dust layers to build up on the equipment.**

2. INSTALLATION INSTRUCTIONS

The Control Unit

The Control Unit box should be installed in a suitable control or starter switch room. The box should have sufficient space to open the lid for wiring.



The Control Unit is susceptible to static voltage. Connection of a clean ground to terminal 29 is essential for optimum performance. Prior to this connection, static handling precautions should be taken.

3 ELECTRICAL WIRING

Refer to Drawings A, B, C & E

When installing the equipment in an area which is likely to be hazardous from Ignitable Dusts, use liquid tight conduit and fittings and follow all local codes.

4 OPERATING INSTRUCTIONS

The Fieldbus Adapter is a self contained unit and there are no user configurable options with the exception of the Ethernet IP address. The adapter is equipped with three communications ports; RS232, RS485 and Ethernet TCP.

The RS232 is a simple interface which can be used for diagnostics purposes. The data from this port is formatted to work with a VT100 display terminal. Any terminal or terminal emulator capable of supporting the VT series or compatible commands can be used with this port although the data has been optimised to work with VT100. The RS232 port operates at a fixed data rate of 9600, N, 8, 1.

The RS485 port is a four wire, twin twisted pair full duplex serial port and has been specifically configured to work with the Watchdog communications network. You should not connect any other devices to this port unless you wish to monitor the Watchdog data directly. If this is the case then contact your supplier for details relating to the Watchdog command protocol.

The Ethernet port meets the requirements of the 10/100Base-T twisted pair Ethernet physical layer. The Ethernet Fieldbus adapter module is designed for use with the general and the Modbus form of the TCP/IP communications model. The Fieldbus module should be connected through a standard Ethernet communications hub/switch. Alternatively, a peer to peer connection could be made using a single crossover or uplink cable. The Fieldbus Ethernet module will support up to 16 simultaneous Ethernet TCP connections. The default configurations used by the Fieldbus module are as follows.

IP Address. 192.168.0. X
Port 502

This module is currently configured for use as part of an intranet network only therefore further settings are not required. By default, the following settings are also applied.

Subnet address 255.255.255.0

Gateway Address 0.0.0.0.

These settings can be ignored as they are only useful when connecting to an internet network.

The last byte of the IP address “X” refers to the settings made on the switches located on the Ethernet module. The switch block contains 8 switches which represent the last 255 addresses of the IP address 192.168.0.1-255. The right most switch (switch 8) is the Least Significant Bit and the leftmost switch (switch 1) is the Most Significant Bit of the address. The switch is on (selected) when in the down position. If all switches are off (all up) then a fault condition is indicated by led 2 flashing green at the rate of about once every second. The address of the module can be changed at any time without the need to recycle power. Caution must always be exercised when working with an open unit when power is still applied.

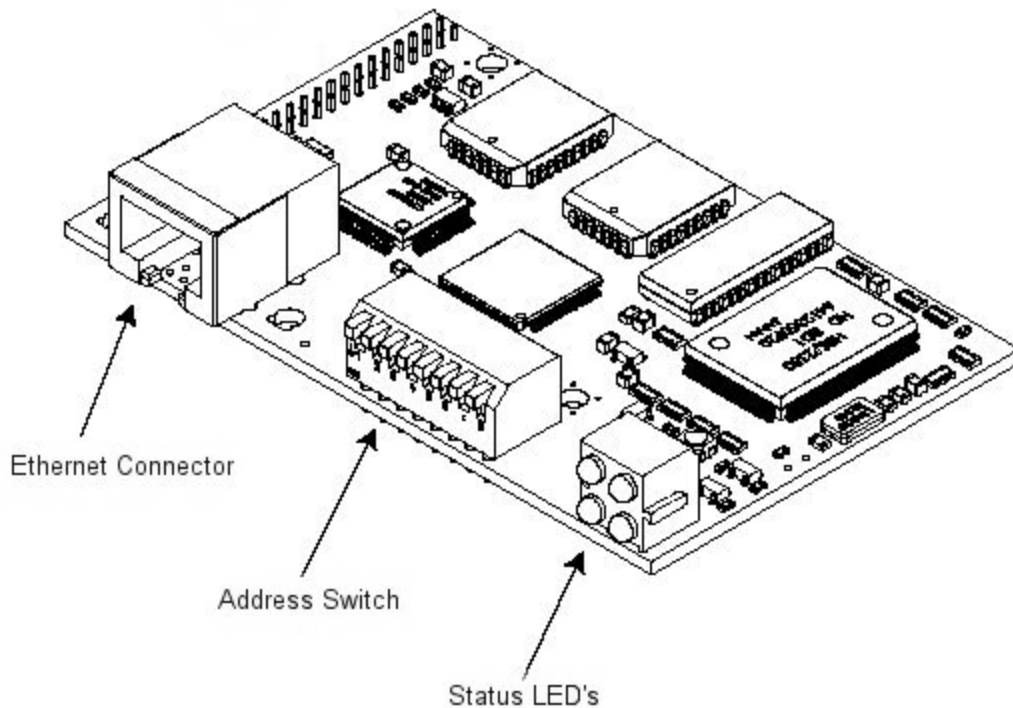

The above diagram shows the location of the main parts of the Ethernet Fieldbus module.

The Ethernet connections are shown below and are identical to the standard Ethernet RJ45 connections.

Connector Pin	Signal	Description.
1	TD+	Positive Transmit Data
2	TD-	Negative Transmit data
3	RD+	Positive Receive Data
4		No Connection
5		No Connection
6	RD-	Negative Receive Data
7		No Connection
8		No Connection
Casing	PE	Protective Earth

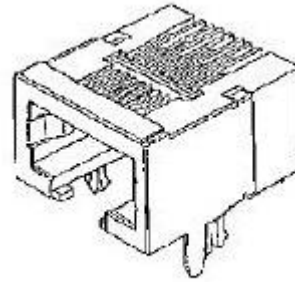

The status LED's are grouped in a single block of four and indicate the following status.

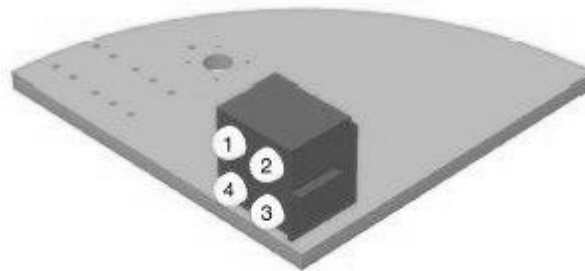

Led 1 Status

<i>Colour</i>	<i>Frequency</i>	<i>Description</i>
Green	Steady on	Indicated that the module is connected to an Ethernet network.

Led 2 Status

<i>Colour</i>	<i>Frequency</i>	<i>Description</i>
Green	1 Hz	Indicated that the used IP address is not set by the value of the DIP switches.
Red	1 Hz	The Ethernet MAC address is not correct. The module will not be able to initialise, please contact your supplier.
Red	2 Hz	This module failed to load Ethernet configuration from the Flash memory.
Red	4 Hz	Internal error, please contact your supplier.

Led 3 Status

<i>Colour</i>	<i>Frequency</i>	<i>Description</i>
Green	-	Indicates the number of Modbus TCP connections that are currently established to the module. The LED flashes to indicate the number of connections. For example, if three connections are made then the LED will flash three times, the LED will be off for a period of about two seconds and then the flash cycle will repeat.

Led 4 Status

<i>Colour</i>	<i>Frequency</i>	<i>Description</i>
Green	-	Flashes from green to off when a packet is received or transmitted.

The following exception status codes may be generated by the F500. These codes are generated when you are using an incorrect data polling method.

Exception Code	Name	Description
01	Illegal Function	This module does not support the function code in the query
02	Illegal Data Address	The data address received in the query is outside the initialised memory area in the module.
03	Illegal Data Value	The data in the request is illegal

When using the interface as general Ethernet interface, the Modbus references may be ignored. The functionality is identical for both Ethernet and Modbus.

Watchdog Address	Input Words	Input Byte
-	0	0-1
1	1 – 17	2 – 35
2	18 – 34	36 – 69
3	35 – 51	70 -104
4	52 – 68	105 -137
5	69 – 85	138 -171
6	86 – 102	172 - 205
7	103 – 119	206 - 239
8	120 – 136	240 - 273
9	137 – 153	274 – 307
10	154 - 170	308 - 341

The Watchdog data is automatically read for up to 10 controllers. The data returned is processed and stored in the following format. The position of the data is fixed within the input data table.

Although data is returned in a word format, much of the data is in either byte pairs (2 bytes per word) or as two single bytes; more on this later.

Word 0 (Byte 1) is used to indicate the number of Watchdogs that are responding to the request for data. Word 0 (Byte 0) is unused. This only occurs once in the entire table. The remaining data stored in the input bytes is constructed as follows.

All the values are stored in Hexadecimal

Number of Watchdogs detected this time (Byte 1,0) Once only	0	No.Of WD	0x0200
Watchdog current speed (Byte 3,2)	1	WD1 Speed	0x0000
Watchdog current operating status (Byte 5,4)	2	Status	0x0000
Under speed alarm and stop in % (Byte 7,6)	3	USA/US5	0x0000
Over speed alarm and stop in % (Byte 9,8)	4	OSA/O55	0x0000
Current calibration value in PPM (Byte 11,10)	5	Calibration PPM	0x0000
Display scaling factor (Byte 13,12)	6	Scale Factor	0x0000
NTC Temperature 1 and 2 (Byte 15, 14)	7	T1/T2	0x0000
NTC Temperature 3 and 4 (Byte 17, 16)	8	T3/T4	0x0000
NTC Temperature 5 and 6 (Byte 19, 18)	9	T5/T6	0x0000
NTC temperature sensor status 1 and 2 (Byte 21,20)	10	ST1/ST2	0x0000
NTC temperature sensor status 3 and 4 (Byte 23,22)	11	ST3/ST4	0x0000
NTC temperature sensor status 5 and 6 (Byte 25,24)	12	ST5/ST6	0x0000
Sensor 1 and sensor 2 alarm level (Byte 27,26)	13	ALM1/ALM2	0x0000
Sensor 3 and sensor 4 alarm level (Byte 29,28)	14	ALM3/ALM4	0x0000
Sensor 5 and sensor 6 alarm level (Byte 31,30)	15	ALM5/ALM6	0x0000
Number of sensors in use (Byte 33), Relay status (Byte 32)	16	NOS/REL	0x0000
Persistent alarm value (Byte 35), update counter (Byte 34)	17	PERALM/CNT	0x0000

The data from each Watchdog is stored in 17 consecutive words (or 34 bytes) of data. The first two bytes of the group of 34 (e.g. 3 & 2) represent the Watchdog speed. The second two bytes of the group of 34 (e.g. 5 & 4) represent the Watchdog status.

The Watchdog speed is encoded in the following manner.

Four hexadecimal digits are used to represent the measured speed for the Watchdog. The rightmost three and a half are the main body of the speed and the upper half of the fourth is the position of the decimal place within the information. If the most significant two bits are '00' then decoding of the speed is not required. If the two bits are '01', then the

resulting value should be divided by 10 and if the two bits are '10' then the speed should be divided by 100. The top two bits should never be '11' as this has no meaning.

Bit 7	Bit 6	Description (e.g. most significant bits of the first speed byte 3)
0	0	Bits 5-0 of the first byte and the whole second represent the speed.
0	1	Same as above but the speed and should be divided by 10
1	0	Same as above but the speed and should be divided by 100
1	1	Not used.

An example of this can be seen below.

Watchdog speed = 6E (e.g. byte 3) & 1E (e.g. byte 2). The leftmost digit (6) = '0110' in binary which can be separated into '01' (bits 7 and 6) for speed scaling and '10' (bits 5 and 4) for the upper speed digit. If you strip off bits 7 and 6 you are left with a decoded value of 2E & 1E for the speed and '01' or divide by 10 for the scaling. The speed 2E1E converted to decimal = 11806 and then divided by 10 results in an actual speed of 1180.6. By default the Watchdog will display speed in pulses per minute but it can be scaled to display any value required, refer to the Watchdog manual for further detail.

The Watchdog status is encoded as described in the following manner.

Two data bytes are used to represent the status for the Watchdog. The first status byte (e.g. byte 5) is the status code and the second byte (e.g. byte 4) represents any data which is associated with the status code. All data is in hexadecimal.

Status Code (Byte 5)	Status Data (Byte 4)	What it means.
09	% Complete	Watchdog is calibrating (% complete).
0F	-	Elevator is stopped due to persistent belt slip.
10	-	Elevator is stopped due to persistent over calibration.
11	-	Misalignment detected on Top & Bottom sensors.
22	-	Elevator is stopped and is ready to run (Normal stop condition)
23	Start-up Delay In seconds	Elevator is accelerating. (xx seconds remain)
24	Speed %	Elevator running within programmed limits.
25	Speed %	Stop relay has been de-energised (Fault stop condition)
27	Time to alarm In seconds	Misalignment detected. (xx seconds to alarm)
2A	Time to alarm In seconds	Over speeding: Alarm relay about to de-energise (xx seconds to alarm)
2D	-	Misalignment detected at the top of the elevator.
2F	Time to stop In seconds	Over speeding: Stop relay about to de-energise (xx seconds to stop)
31	-	Speed display is over range: check the scaling factor.
32	-	Start elevator to commence calibration procedure.
36	1-4	Watchdog has detected an internal fault.
39	Time to alarm In seconds	Belt slipping. (xx seconds to alarm)

3A	Time to stop In seconds	Belt slipping: Stop relay about to de-energise. (xx seconds to stop)
3B	-	Elevator stopped due to lack of acceleration.
3C	Time to stop In seconds	Persistent alarm. (xx seconds to alarm)
3D	-	Elevator stopped: Speed has exceeded over speed limit.
3E	-	Interlock signal off, waiting for zero speed.
3F	-	Elevator stopped: Persistent alarm condition.
40	-	Elevator stopped: Severe under speed.
41	-	Watchdog is not calibrated: Please see the manual.
42	-	Misalignment detected at the bottom of the elevator.
44	-	Wrong access code used when changing setup.
46	Speed %	Elevator speed less than alarm level (slipping)
47	Speed %	Elevator speed more than alarm level (Over speeding)
49	-	Suspected open circuit or faulty PTC bearing temperature sensor.
4A	-	Suspected fault on one or more MAS. Could be mains pickup.
4E	-	Plug switch is open.
50	-	PTC Hot bearing at zone 1.
51	-	PTC Hot bearing at zone 2.
52	-	PTC Hot bearing at zone 3.
53	-	PTC Hot bearing at zone 4.
54	-	PTC Hot bearing at zone 5.
55	-	PTC Hot bearing at zone 6.
56	-	HBS is open circuit at zone 1
57	-	HBS is open circuit at zone 2
58	-	HBS is open circuit at zone 3
59	-	HBS is open circuit at zone 4
5A	-	HBS is open circuit at zone 5
5B	-	HBS is open circuit at zone 6

An example of the status code might be '2463'. The first status byte (byte 5) '24' show that the equipment is running within the specified alarm limits and the second status byte (byte 4) '63' indicate that the speed is 99% if it's calibrated value. Where a value is not shown or a '-' is used in the table, this indicates that any data present in this field should be ignored.

Several different conditions may occur at the same time whilst the Watchdog is operating. If the Watchdog is running within calibrated range but also detects a motion sensor fault then the information returned may look something like this.

'2463' Running at 99% of calibrated speed.
Followed three seconds later by
'2D--' Misalignment detected at the top of the elevator.
Followed three seconds later by
'3CAA' Persistent alarm, 170 seconds to go.

The messages would then repeat with any new values in the status data field.

Due to some limitations in the speeds involved in updating the Watchdog information, rapid changed of data could be missed or be present for only a very short period of time.

If the Watchdog is placed in one of the two test modes, the messages below will be returned in the following order.

Bytes 3 and 2	Bytes 5 and 4	The first two bytes show the speed data and the second two bytes show the status and status data.
xx & xx	06 & xx	Over speed Stop as a percentage of calibrated speed.
xx & xx	05 & xx	Over speed Alarm as a percentage of calibrated speed.
xx & xx	02 & xx	The actual calibrated speed
xx & xx	03 & xx	Under speed Alarm as a percentage of calibrated speed.
xx & xx	04 & xx	Under speed Stop as a percentage of calibrated speed.
----	07 & --	Performing internal test.
----	4C & --	Testing the Alarm relay.
----	4D & --	Testing the Stop relay.

Codes 4C and 4D are only returned if the extended test is in operation.

Under speed alarm and stop in % (Byte 7, 6)

These two bytes show (in % of calibrated speed) the under speed alarm and stop levels. These represent the point at which the Watchdog will generate an alarm or stop condition. Example, if byte 7 is '0A' and byte 6 is '14' then this means that the Watchdog will generate an under speed alarm at 10% (0A) below calibrated speed and will generate a stop condition at 20% (14) below the calibrated speed.

Over speed alarm and stop in % (Byte 9, 8)

These two bytes show (in % of calibrated speed) the over speed alarm and stop levels. These represent the point at which the Watchdog will generate an alarm or stop condition. Example, if byte 9 is '0A' and byte 8 is '14' then this means that the Watchdog will generate an over speed alarm at 10% (0A) above calibrated speed and will generate a stop condition at 20% (14) above the calibrated speed.

Current calibration value in PPM (Byte 11, 10)

These two bytes represent the current calibration speed value in Pulses Per Minute (Default). The representation can be changed to other scaled values by using the display scaling value below. Refer to the Watchdog manual for further details about display scaling.

Display scaling factor (Byte 13, 12)

These two bytes contain a value which is used by the Watchdog to scale the information on the display into a format which represents more accurately what the elevator is doing. The default scaling factor (04B0) results in the display showing the current speed in PPM. Refer to the Watchdog manual for further details about display scaling.

NTC Temperature 1 and 2 (Byte 15, 14)

These two bytes show the actual temperature of temperature sensors 1 & 2. The values are in Dec C or Deg F according to the settings on the Watchdog. Refer to the Watchdog manual NTC section for more detail.

NTC Temperature 3 and 4 (Byte 17, 16) & NTC Temperature 5 and 6 (Byte 19, 18)

See the detail above for temperature sensors 1 and 2

NTC temperature sensor status 1 and 2 (Byte 21, 20)

These two bytes show the current status of temperature sensors number 1 & 2.

If byte 21 is 0 then sensor 1 is NORMAL

If byte 21 is 1 then the temperature of sensor 1 is HIGH so an alarm has been generated.

If byte 21 is 2 then sensor 1 may be OPEN circuit

If byte 21 is 3 then sensor 1 may be SHORT circuit

NTC temperature sensors 2 to 6 operate in an identical manner as described for sensor 1 above.

Sensor 1 and sensor 2 alarm level (Byte 27,26)

These two bytes represent the alarm value for the temperature sensor. The default values for this alarm level are '9E' (158) when measuring in Deg 'F' and '50' (80) when measuring in Deg 'C'. Refer to the Watchdog manual for further detail regarding this value.

Sensor 3 and sensor 4 alarm level (Byte 29, 28) & Sensor 5 and sensor 6 alarm level (Byte 31, 30) operate in an identical manner as described above.

Number of sensors in use (Byte 33)

Byte 33 shows the total number of NTC temperature sensors that are currently being monitored by the Watchdog. This value ranges from 0 to 6. See the watchdog manual for further detail.

Relay status (Byte 32)

This byte contains information relating to the status of the Watchdog LED's and Relays. Although the byte is represented in Hexadecimal converting it to binary helps to explain the contents a little better.

0000:0000 The left hand four bits are always **0000** and can be ignored.

0000:0000 The right hand four bits contain the following information.

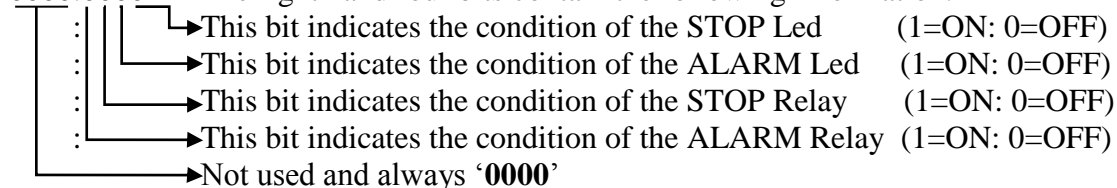

When a relay is considered to be 'ON' we mean energized and when 'OFF' we mean de-energized.

0000:0000 = 00 then no conditions exist
 0000:0010 = 02 then the alarm Led is on
 0000:1010 = 0A then the alarm Led and Alarm Relay are active
 0000:0011 = 03 then both Led's are 'on' and both Relays are 'off' (de-energized)

Persistent alarm value NTC only (Byte 35)

This is how long the temperature alarm will take in seconds before stopping the elevator. The default value is 'B4' 180 seconds. If this value reaches '0' then the elevator will be stopped.

Update counter (Byte 34)

Every time the F500 successfully receives information from the chosen watchdog, then this counter value will be incremented by 1. The watchdog treats serial communications as low priority so occasionally requests for data can be ignored. It is advisable to keep checking this value so as to know when new data has arrived in the F500. The counter will increment from 0 to 255 and then return to 0 again in a continuous loop.

Below is an example of the data returned when the F500 is polling Watchdogs.

	Alias	00000	Alias	00010	Alias	00020	Alias	00030	Alias	00040	Alias	00050
0	No.Of WD	0x0100	ST1/ST2	0x0000	USA/US5	0x0A14	ALM1/ALM2	0x9E9E	Scale Factor	0x04B0	NOS/REL	0x0103
1	WD1 Speed	0x0000	ST3/ST4	0x0000	OSA/O55	0x0A14	ALM3/ALM4	0x9E9E	T1/T2	0x6C4F	PERALM/CNT	0x004B
2	Status	0x0000	ST5/ST6	0x0000	Calibration P...	0x0475	ALM5/ALM6	0x9E9E	T3/T4	0x42C2	WD4 Speed	0x0000
3	USA/US5	0x0000	ALM1/ALM2	0x0000	Scale Factor	0x04B0	NOS/REL	0x0208	T5/T6	0x11AA	Status	0x0000
4	OSA/O55	0x0000	ALM3/ALM4	0x0000	T1/T2	0x4C50	PERALM/CNT	0xB49C	ST1/ST2	0x0200	USA/US5	0x0000
5	Calibration PPM	0x0000	ALM5/ALM6	0x0000	T3/T4	0x3000	WD3 Speed	0x0000	ST3/ST4	0x0000	OSA/O55	0x0000
6	Scale Factor	0x0000	NOS/REL	0x0000	T5/T6	0x4158	Status	0x4100	ST5/ST6	0x0000	Calibration PPM	0x0000
7	T1/T2	0x0000	PERALM/CNT	0x0000	ST1/ST2	0x0000	USA/US5	0x0A14	ALM1/ALM2	0x0045	Scale Factor	0x0000
8	T3/T4	0x0000	WD2 Speed	0x0484	ST3/ST4	0x0000	OSA/O55	0x0A14	ALM3/ALM4	0x20D6	T1/T2	0x0000
9	T5/T6	0x0000	Status	0x2465	ST5/ST6	0x0000	Calibration PPM	0xFF19	ALM5/ALM6	0x8B4B	T3/T4	0x0000

Words 1 to 17 (pink) represent Watchdog 1. These are currently all 0 because watchdog 1 isn't present at this time. Words 18 to 34 (green) represent Watchdog 2. Word 18 which is 0484 HEX tells us that the Watchdog is currently running at 1156 pulses per minutes. Word 19 which is 2465 HEX tells us that the Watchdog is 'running (24) at 101% (65) of the calibrated speed. The remainder of the information in the example can be decoded using the information as previously described. Words 35 to 51 (blue) represent Watchdog 3. Word 35 which is 0000 HEX tells us that the Watchdog is currently NOT running. Word 36 which is 4100 HEX tells us that the Watchdog is in fact NOT calibrated (41), see the Watchdog manual for more detail about calibration.

Diagnostics Display.

The F500 Elite is equipped with a simple RS232 serial interface. This interface can be used to monitor the communications with the Watchdog Elite. The information displayed contains diagnostic data about the Fieldbus module and Watchdog number 1. A VT100 or compatible display terminal should be used to display the information.

```
F500 Elite Communications Gateway - Watchdog NTC
Elite Software Version - 6.0.0
```

```
CBU Version= 1.00
API Version= 3.05
FBI Version= 1.53
ABI Version= 1.53
FieldBus Type = Ethernet TCP/IP + IT)
S2468E
```

```
DATA ARRAY FOR WATCHDOG NUMBER 1
  Speed 0483          ST1/ST2 0000
  Status 2465        ST3/ST4 0000
  USA/USS 0A14       ST5/ST6 0000
  OSA/OSS 0A14       ALM1/ALM2 9E9E
  Calib 0475         ALM3/ALM4 9E9E
  Scaling 04B0       ALM5/ALM6 9E9E
  T1/T2 4E47         NOS/REL 0208
  T3/T4 3000         P-ALM/CNT B40C
  T5/T6 4158
```

```
Total Watchdogs Read = 1
```

Above is an *example* screen image from the diagnostics display. The information displayed will vary slightly dependent upon the fieldbus interface used.

CBU Version = X.XX	– This is the control base unit software version.
API Version = X.XX	– This is the application interface software version.
FBI Version = X.XX	– This is the Fieldbus interface software version.
ABI Version = X.XX	– This is the AnyBus interface software version.

Fieldbus type = Ethernet TCP/IP – This describes the type of Fieldbus module which is installed in the F500 Elite. If the Fieldbus module is faulty some or all of this data will change to suggest which area may be at fault. For example, FBI version number might become 245.55. An unusually large number such as this is not usually associated with a normally functioning module and would suggest that the Fieldbus interface controller has failed. In the event of this or any other fault, contact your supplier.

The sequence S2468E indicated that the system has initialised correctly, a deviation from this indicates that one or more parts of the initialisation process has failed. If this is the case, recycle power and see if this clears the problem. If you still have problems with the initialisation of the unit contact your supplier and tell them what you see on the

diagnostics display. The main area of the display shows the complete data from Watchdog address number 1 as described on pages 8 to 13 of this manual.

Diagnostics LED.

Located on the main circuit board, just above the RS485 connections to the Watchdog you will find an LED indicator (usually RED). This indicator will flash every time the F500 attempts to communicate with the Watchdogs. The LED will normally flash at a consistent rate followed by a very short pause. The short pause indicates that the F500 is updating the information which it stores internally. A significant deviation from this sequence is an indication that there is a problem. If this happens, contact your supplier for further information.

CHECK LIST
For problems after initial start-up

1. Is there excessive interference on the electrical power supply? Power conditioners and surge (spike) suppressor may have to be fitted.
2. Has the wiring for the Watchdog and Fieldbus been routed away from power cables?
3. Is the F500 Elite circuit properly grounded?
4. Is the Micro-processor control unit overheating, if so mount in temperature-controlled environment of maximum temperature 104°F (40°C).
5. Check that high powered 'Walkie Talkie' radios are not operated immediately near the control unit or Watchdogs as this will affect the performance.
6. Check that the communications/power cable is connected correctly and in accordance with DRG A,B,C and E.
7. Check that there is no exception status reported.
8. If only part of the diagnostics data is displayed on the terminal screen then turn the F500 Elite off then back on again without removing power to the display terminal.
9. If the Watchdogs are not responding or are intermittent, check that the termination resistors are correctly fitted.

CONTACT INFORMATION



WWW.GO4B.COM

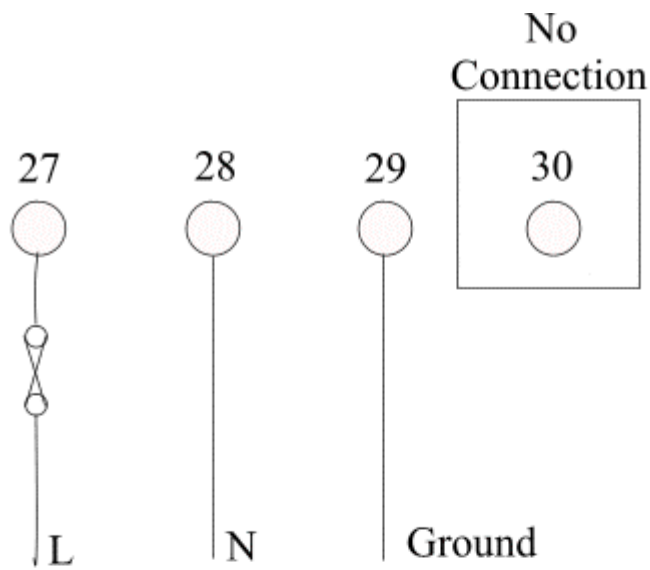

115 - 240 VAC 50/60 Hz

DRG 'A'

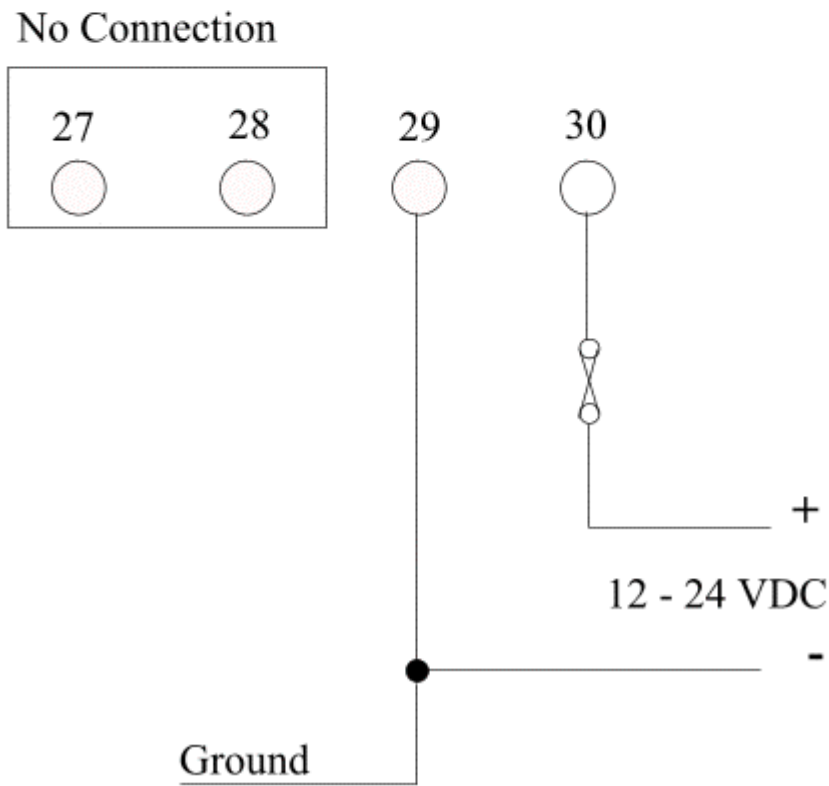

DRG 'B'

F500 elite to Watchdog connections

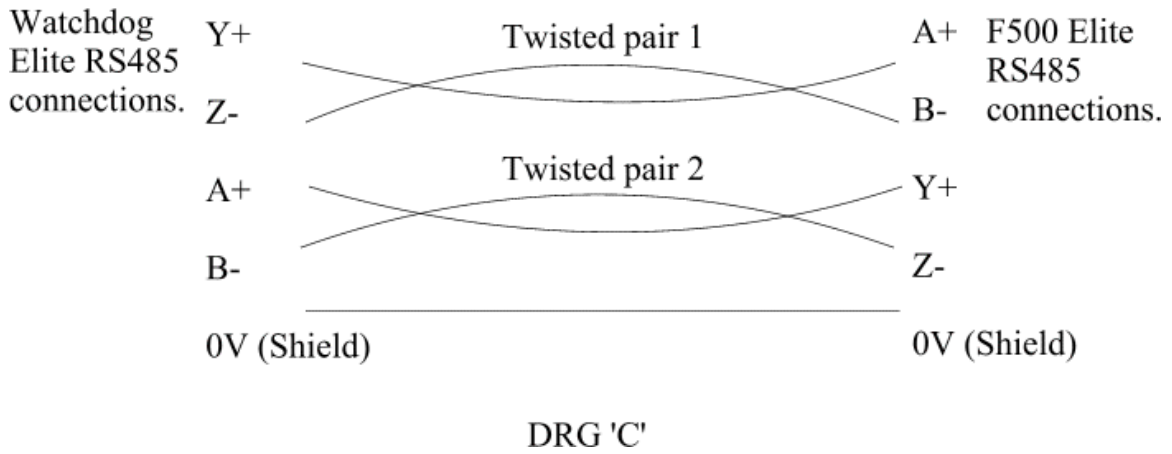
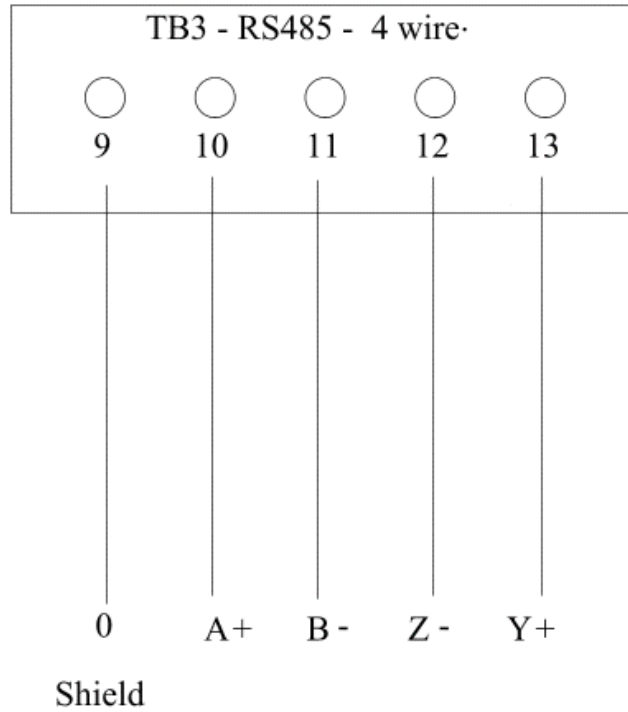

F500 elite to VT100 terminal connections.

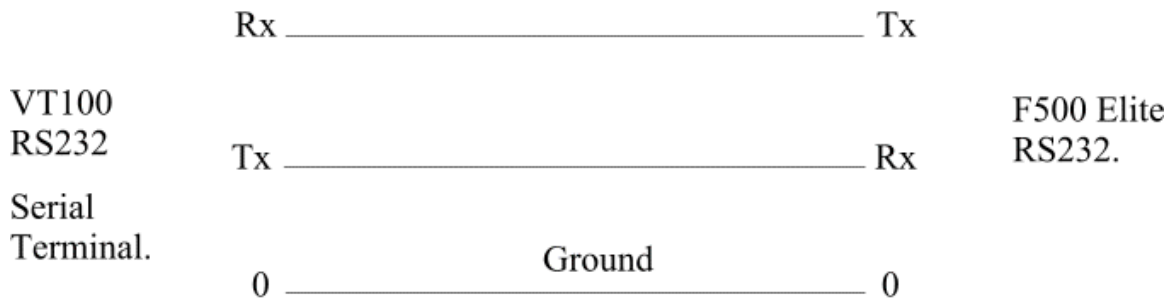
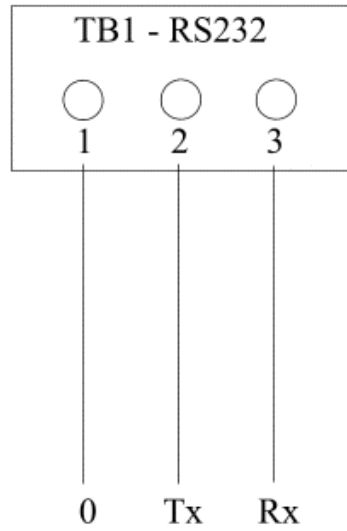

On more recent versions of the F500 TB1 may be a standard 9 pin Dee connector. This Dee connector is designed to work with a standard 9 pin to 9 pin serial lead for monitoring the F500

DRG 'D'

General connection detail for the Watchdog to an F500 elite.

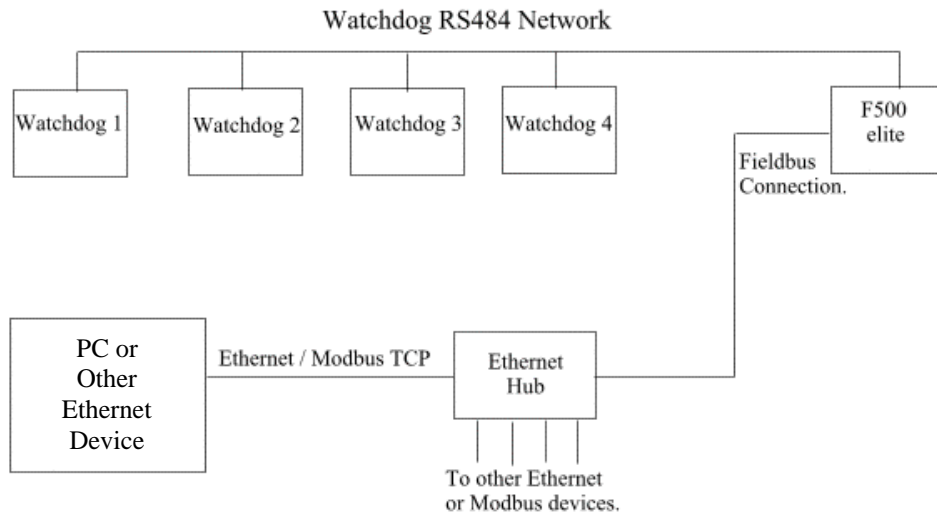
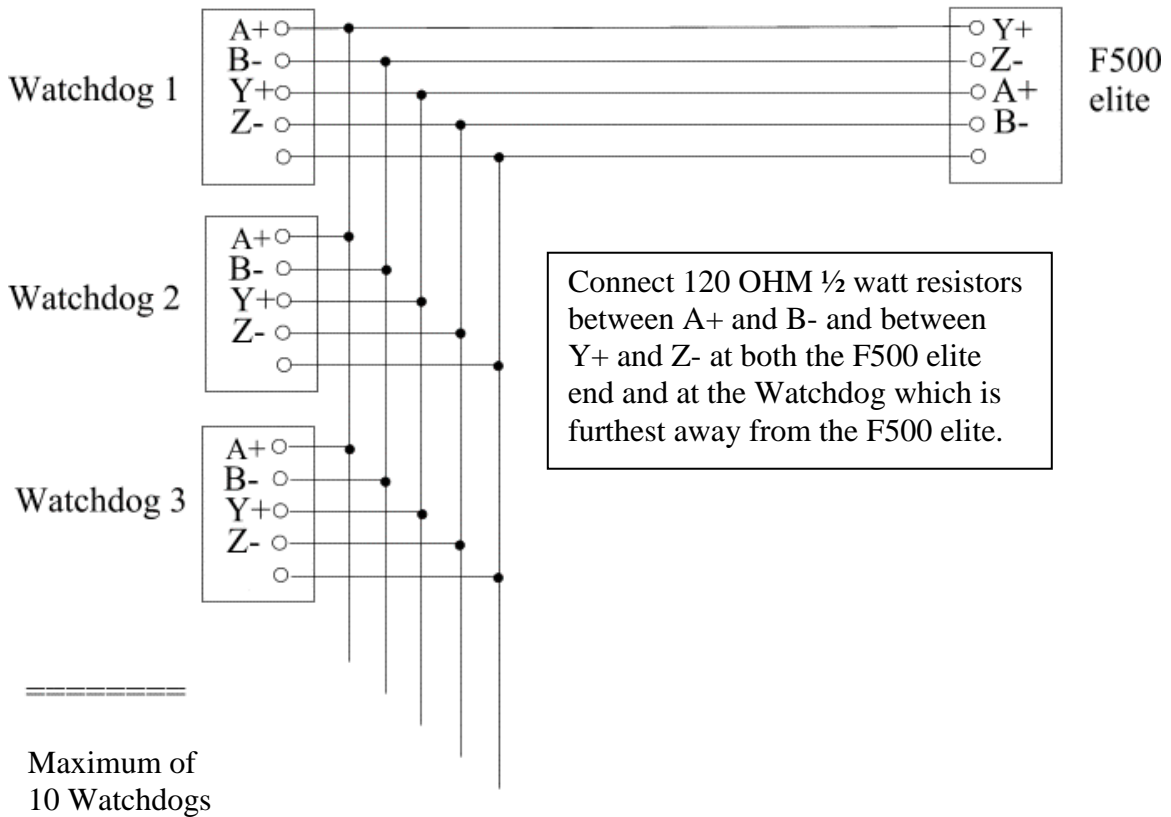

DRG 'E'

Appendix 'A'

The table below represents the settings for the Ethernet address switch as described on page 5. The F500 is supplied with a default IP address of 192.168.0.100. The last three numbers of the address can be changed to eliminate conflicts with existing IP address's already in use on your Ethernet system. The switches are numbered 1 to 8 left to right and switch 8 represents the lowest binary number. In the table below a '0' represents the switch in the OFF or UP position and a '1' represents the switch in the DOWN or ON position. The table is made up in the following format

ABC 12345678

Where ABC is the last part of the IP address 192.168.0.ABC and 12345678 represents the switch number from left to right.

001	00000001	033	00100001	065	01000001	097	01100001
002	00000010	034	00100010	066	01000010	098	01100010
003	00000011	035	00100011	067	01000011	099	01100011
004	00000100	036	00100100	068	01000100	100	01100100
005	00000101	037	00100101	069	01000101	101	01100101
006	00000110	038	00100110	070	01000110	102	01100110
007	00000111	039	00100111	071	01000111	103	01100111
008	00001000	040	00101000	072	01001000	104	01101000
009	00001001	041	00101001	073	01001001	105	01101001
010	00001010	042	00101010	074	01001010	106	01101010
011	00001011	043	00101011	075	01001011	107	01101011
012	00001100	044	00101100	076	01001100	108	01101100
013	00001101	045	00101101	077	01001101	109	01101101
014	00001110	046	00101110	078	01001110	110	01101110
015	00001111	047	00101111	079	01001111	111	01101111
016	00010000	048	00110000	080	01010000	112	01110000
017	00010001	049	00110001	081	01010001	113	01110001
018	00010010	050	00110010	082	01010010	114	01110010
019	00010011	051	00110011	083	01010011	115	01110011
020	00010100	052	00110100	084	01010100	116	01110100
021	00010101	053	00110101	085	01010101	117	01110101
022	00010110	054	00110110	086	01010110	118	01110110
023	00010111	055	00110111	087	01010111	119	01110111
024	00011000	056	00111000	088	01011000	120	01111000
025	00011001	057	00111001	089	01011001	121	01111001
026	00011010	058	00111010	090	01011010	122	01111010
027	00011011	059	00111011	091	01011011	123	01111011
028	00011100	060	00111100	092	01011100	124	01111100
029	00011101	061	00111101	093	01011101	125	01111101
030	00011110	062	00111110	094	01011110	126	01111110
031	00011111	063	00111111	095	01011111	127	01111111
032	00100000	064	01000000	096	01100000	128	10000000

129	10000001	161	10100001	193	11000001	225	11100001
130	10000010	162	10100010	194	11000010	226	11100010
131	10000011	163	10100011	195	11000011	227	11100011
132	10000100	164	10100100	196	11000100	228	11100100
133	10000101	165	10100101	197	11000101	229	11100101
134	10000110	166	10100110	198	11000110	230	11100110
135	10000111	167	10100111	199	11000111	231	11100111
136	10001000	168	10101000	200	11001000	232	11101000
137	10001001	169	10101001	201	11001001	233	11101001
138	10001010	170	10101010	202	11001010	234	11101010
139	10001011	171	10101011	203	11001011	235	11101011
140	10001100	172	10101100	204	11001100	236	11101100
141	10001101	173	10101101	205	11001101	237	11101101
142	10001110	174	10101110	206	11001110	238	11101110
143	10001111	175	10101111	207	11001111	239	11101111
144	10010000	176	10110000	208	11010000	240	11110000
145	10010001	177	10110001	209	11010001	241	11110001
146	10010010	178	10110010	210	11010010	242	11110010
147	10010011	179	10110011	211	11010011	243	11110011
148	10010100	180	10110100	212	11010100	244	11110100
149	10010101	181	10110101	213	11010101	245	11110101
150	10010110	182	10110110	214	11010110	246	11110110
151	10010111	183	10110111	215	11010111	247	11110111
152	10011000	184	10111000	216	11011000	248	11111000
153	10011001	185	10111001	217	11011001	249	11111001
154	10011010	186	10111010	218	11011010	250	11111010
155	10011011	187	10111011	219	11011011	251	11111011
156	10011100	188	10111100	220	11011100	252	11111100
157	10011101	189	10111101	221	11011101	253	11111101
158	10011110	190	10111110	222	11011110	254	11111110
159	10011111	191	10111111	223	11011111	255	11111111
160	10100000	192	11000000	224	11100000		

The entry in the table above which has a grey background represents the default switch settings.

Appendix 'B'

The F500 Elite Ethernet interface is preconfigured to operate with an IP address of 192.168.0.100. This is acceptable in most instances. We recommend that you use static IP address allocation in order to minimize difficulty with address conflict. Please refer to your system supplier or maintenance department for details of how to add or change a static IP address for your Ethernet system.

Below is a method by which you can change the IP, Subnet and Gateway addresses for the F500 Ethernet interface. This method requires advanced knowledge of this type of procedure and it is not recommended that you use it unless you are familiar with the requirements.

The reconfiguration process must be done on one of the computers that will be connected to the F500 in order for it to work correctly. It is assumed that the hardware is all connected and powered up.

Assuming that the computer IP address is 182.169.106.3 and the subnet mask is 255.255.255.0, it is possible to reconfigure the F500 Ethernet module to 182.169.106.XXX. If the subnet mask isn't as described above then this method will not work.

Before making any changes you must do the following.

Open as DOS box (DOS prompt) on the PC in question.

At the DOS prompt type '**telnet 192.168.0.100**' (without the quotes) press enter (this is the existing IP address for the F500) and you should see the following prompt appear-

HMS AnyBus-S Ethernet module

Admin mode, no login required

|>

At the prompt type '**version**' and press enter. You should then see something similar to that shown below.

HMS AnyBus-S Ethernet module

Software version: 1.13.01

Bootloader version: 1.11.01

Serial number: 0xA000EE60

MAC address: 00-30-11-02-07-6F

FB type: 0x0083

The information that you need is the MAC address so write this down exactly as you see it. Then type '**exit**' and you should see...

Connection to host lost.

Press any key to continue...

And then you should be back to your original dos prompt.

Set all of the F500 switches to the UP position (off).

Now type the following, the [] characters is used to represent a space just to make it clearer.

Arp[]-s[]182.169.106.XXX[] followed by the MAC address that you wrote down earlier.

For example, you could type:-

Arp[]-s[]182.169.106.100[]00-30-11-02-07-6F then press the enter key. The last part of the IP address (100) is a randomly chosen number that doesn't conflict with any other IP address on the system. The actual address you will end up using will be set by the F500 Ethernet module switches.

Still at the dos prompt type **arp[]-a** and press enter. You should see something similar to this.

```
Interface: 182.169.106.30 --- 0x10003
Internet Address      Physical Address      Type
182.169.106.100      00-30-11-02-07-6f    static
182.169.106.3        00-40-2b-25-ed-ac    dynamic
```

What you see doesn't ready matter as long as you see your IP and MAC address as entered.

Now type **ping 182.169.106.100** and press enter.

You should now see:-

Pinging 182.169.106.100 with 32 bytes of data:

Reply from 182.169.106.100: bytes=32 time=3ms TTL=30

Reply from 182.169.106.100: bytes=32 time=1ms TTL=30

Reply from 182.169.106.100: bytes=32 time=1ms TTL=30

Reply from 182.169.106.100: bytes=32 time<1ms TTL=30

Ping statistics for 182.169.106.100:

Packets: Sent = 4, Received = 4, Lost = 0 (0% loss),

Approximate round trip times in milliseconds:

Minimum = 0ms, Maximum = 3ms, Average = 1ms

If you don't get this or similar as the result then you will have to repeat the cycle again.

The process is now complete. If required, you can leave the F500 module switches set to all off and you will be able to use the fixed address that you programmed (182.168.106.100 in the example) or you can set the switches according the table in Appendix 'A' of this manual if you want a different ending address.