



F500 Elite

T500 FIELDBUS ADAPTER -
ETHERNET IP / MODBUS TCP



INSTALLATION INSTRUCTIONS

OPERATION MANUAL

Part No. F5004V46CAI-ETH / F5004V4CAI-ETH
Software Version 7.x.x

www.go4b.com

TABLE OF CONTENTS

CUSTOMER SAFETY RESPONSIBILITIES	Page 4 - 5
PRODUCT OVERVIEW	Page 6
SPECIFICATIONS	Page 6-7
INSTALLATION	Page 8
HARDWARE DESCRIPTION	Page 8
OPERATION DESCRIPTION	Page 9
ETHERNET SETTING SETUP	Page 9 - 10
F500 eVIEW WEBSITE -	Page 11
- Live Page View	Page 12
- System Settings	Page 14
- Set Sensor Names	Page 15
- Network Settings	Page 15 - 16
- Set Email List	Page 17
- Support Link	Page 17
- Email Notifications	Page 17
F500 PLC DATA ACCESS - MODBUS TCP / ETHERNET IP -	Page 18
- Modbus TCP Connection Settings	Page 18
- T500 Blocks	Page 18
- F500 Data Storage Table	Page 19 - 20
- System Information (Word 0 to 9)	Page 20
- Node Types (Word 205 to 220)	Page 21
- Sensor Alarms (Word 185 to 200)	Page 21
- Sensor Data Section (Word 10 to 137)	Page 22
- TN4 Sensor Data Decoding	Page 22
- SN2 Sensor Data Decoding	Page 22
- Node State / Ambient Temperature Section (Word 140 to 171)	Page 23
- TN4 Node Ambient Decoding	Page 23
- SN2 Input Status Decoding	Page 23
- Remote Alarm Acknowledgement	Page 24
- The Alarm Acknowledgement Process	Page 24
TROUBLESHOOTING GUIDE	Page 25
APPENDIX 1 - SUPPLY VOLTAGE WIRING	Page 26
APPENDIX 2 - T500 TO F500 CONNECTION DIAGRAM	Page 27
APPENDIX 3 - GENERAL CONNECTION DETAILS	Page 28
APPENDIX 4 - ETHERNET IP ADDRESS SWITCH SETTINGS	Page 29 - 30
PRODUCT WARRANTY	Page 32

Dear 4B Customer:

Congratulations on your purchase. 4B appreciates your business and is pleased you have chosen our products to meet your needs.

Please read in its entirety and understand the literature accompanying the product before you place the product into service. Please read the safety precautions carefully before operating the product. With each product you purchase from 4B, there are some basic but important safety considerations you must follow to be sure your purchase is permitted to perform its design function and operate properly and safely, giving you many years of reliable service. Please read and understand the Customer Safety Responsibilities listed below. Failure to follow this safety directive and the Operation Manuals and other material furnished or referenced, may result in serious injury or death.

SAFETY NOTICE TO OUR CUSTOMERS

- A. In order to maximize efficiency and safety, selecting the right equipment for each operation is vital. The proper installation of the equipment, and regular maintenance and inspection is equally important in continuing the proper operation and safety of the product. The proper installation and maintenance of all our products is the responsibility of the user unless you have asked 4B to perform these tasks.
- B. All installation and wiring must be in accordance with Local and National Electrical Codes and other standards applicable to your industry. (Please see the article “Hazard Monitoring Equipment Selection, Installation and Maintenance” at www.go4b.com.) The installation of the wiring should be undertaken by an experienced and qualified professional electrician. Failure to correctly wire any product and/or machinery can result in the product or machine failing to operate as intended, and can defeat its design function.
- C. Periodic inspection by a qualified person will help assure your 4B product is performing properly. 4B recommends a documented inspection at least annually and more frequently under high use conditions.
- D. Please see the last page of this manual for all warranty information regarding this product.

CUSTOMER SAFETY RESPONSIBILITIES

1. READ ALL LITERATURE PROVIDED WITH YOUR PRODUCT

Please read all user, instruction and safety manuals to ensure that you understand your product operation and are able to safely and effectively use this product.

2. YOU BEST UNDERSTAND YOUR NEEDS

Every customer and operation is unique, and only you best know the specific needs and capabilities of your operation. Please call the 24-hour hotline at 309-698-5611 for assistance with any questions about the performance of products purchased from 4B. 4B is happy to discuss product performance with you at any time.

3. SELECT A QUALIFIED AND COMPETENT INSTALLER

Correct installation of the product is important for safety and performance. If you have not asked 4B to perform the installation of the unit on your behalf, it is critical for the safety of your operation and those who may perform work on your operation that you select a qualified and competent electrical installer to undertake the installation. The product must be installed properly to perform its designed functions. The installer should be qualified, trained, and competent to perform the installation in accordance with Local and National Electrical Codes, all relevant OSHA Regulations, as well as any of your own standards and preventive maintenance requirements, and other product installation information supplied with the product. You should be prepared to provide the installer with all necessary installation information to assist in the installation.

4. ESTABLISH AND FOLLOW A REGULAR MAINTENANCE AND INSPECTION SCHEDULE FOR YOUR 4B PRODUCTS

You should develop a proper maintenance and inspection program to confirm that your system is in good working order at all times. You will be in the best position to determine the appropriate frequency for inspection. Many different factors known to the user will assist you in deciding the frequency of inspection. These factors may include but are not limited to weather conditions; construction work at the facility; hours of operation; animal or insect infestation; and the real-world experience of knowing how your employees perform their jobs. The personnel or person you select to install, operate, maintain, inspect or perform any work whatsoever, should be trained and qualified to perform these important functions. Complete and accurate records of the maintenance and inspection process should be created and retained by you at all times.

5. RETAIN AND REFER TO THE OPERATION MANUAL FOR 4B'S SUGGESTED MAINTENANCE AND INSPECTION RECOMMENDATIONS

As all operations are different, please understand that your specific operation may require additional adjustments in the maintenance and inspection process essential to permit the monitoring device to perform its intended function. Retain the Operation Manual and other important maintenance and service documents provided by 4B and have them readily available for people servicing your 4B equipment. Should you have any questions, please call the free 24-hour hotline number (309-698-5611).

6. SERVICE REQUEST

If you have questions or comments about the operation of your unit or require the unit to be serviced please contact the 4B location who supplied the product or send your request via fax (309-698-5615) or call us via our 24-hour hotline number in the USA (309-698-5611). Please have available product part numbers, serial numbers, and approximate date of installation. In order to assist you, after the product has been placed into service, complete the online product registration section which is accessed via our website www.go4b.com/usa.

WARNING

- Rotating machinery can cause serious injury or death
- Always lockout and tagout the machine prior to installation

PRODUCT OVERVIEW

The F500 Elite Fieldbus Adapter is a communications gateway that allows a single point access to a number of 4B T500 Elite communication systems (up to four) or ten 4B Watchdog™ Elite via Fieldbus protocol. Depending on the F500 model different Fieldbus communication protocols are supported, including the most popular ones like Ethernet IP, Modbus TCP, Modbus RTU, DeviceNet, Profibus and others. The unit is housed in a self-contained wall-mounting plastic enclosure.

This manual is for the T500 Elite Hotbus™ to Ethernet IP/ Modbus TCP model. Contact 4B for information on other Fieldbus protocols, or if you are interfacing with a Watchdog™ hazard monitoring system.

F500 Key Features -

- CSA(USA and Canada), ATEX and IECEx approved (Note: different models may have different approvals)
- eView Website - Live plant monitoring with modern and user-friendly interface that work on all major computers and mobile browsers from anywhere in the world 24/7
- Email Notifications - Immediate Alarm notifications to multiple email addresses with the link to eView website for live view of the plant. This allows operators, maintenance, management, etc. to stay on top of the problems and resolve alarms as soon as they appear. This also offers traceability of all alarm events as sensor alarm change events are stored in the email accounts subscribed
- MODBUS TCP - This protocol is supported by all major PLC manufacturers allowing a full and easy integration into SCADA/DCS system
- Seamless Integration with T500 System - This unit has been specifically designed to work with T500 systems, which results in full interoperability
- Multi-Voltage Power Supply - F500 unit can be powered by 24 VDC as well as 120 to 240 VAC (Note: F5004V46C-ETH model required)

SPECIFICATIONS

Supply Voltage	120 to 240 VAC or 24 VDC (F5004V46C-ETH) 24 VDC (F5004V4C-ETH)
Power Consumption (Max.)	12 Watts Maximum
Power Terminals	14 AWG / 4 mm ²
T500 Terminals	RS485 Shielded - 2 Twisted Pair
Fieldbus Connection	Ethernet RJ45 Connector
Dimensions (H x W x D)	9.7 x 7.4 x 4 (inches) / 246 x 188 x 102 (mm)
Fixing Centres (H x W)	8.75 x 4 (inches) / 222 x 102 (mm)
Cable Entry	2 Holes 11/8 in. Diameter (28 mm) - 3/4 in. Conduit
Weight	3 lbs / 1.3 Kg
Approvals	<p>ATEX / IECEx - V4 Ex tb IIIC T125° Db IP66 TAMB -20°C to +50°C IECEx BAS05.0026X 1180 Ex II 2D Ex tb IIIC T125° Db IP66 TAMB -20°C to +50°C Baseefa04ATEX0131X</p> <p>ATEX / IECEx - V46 Ex tc IIIC T125°Dc IP66 TAMB -20°C to +45°C IECEx BAS11.0018X 1180 Ex II 3D Ex tc IIIC T125°Dc IP66 TAMB -20°C to +45°C Baseefa II ATEX 0033X</p> <p>CSA - V4 Ex tb IIIC T125°C Db IP66 Tamb -20°C to +50°C Zone 21 AEx tb IIIC T125°C Db IP66 Tamb -20°C to +50°C Class II Division 1, Groups E, F and G T125°C (When used with a Class2 power supply)</p> <p>CSA - V46 Ex tc IIIC T125°C Dc IP66 Tamb -20°C to +45°C Zone 22 AEx tc IIIC T125°C Dc IP66 Tamb -20°C to +45°C Class II Division 2, Groups F and G T125°C</p> <p>IP66</p>

Conditions of use:

1. The equipment shall be suitably earth bonded via the PCB mounted earth terminal inside the equipment enclosure.
2. **Warning:** The equipment is a potential static hazard, clean only with a damp cloth.
3. Do not allow dust layers to build up on the equipment.

INSTALLATION

All wiring must be in accordance with local and national electrical codes and should be undertaken by an experienced and qualified electrician. For electrical wiring instructions please refer to Appendix 1 and Appendix 2.

For CSA environments always use dust/liquid tight flexible metal conduit with approved fittings to protect the sensor cables. Use rigid metal conduit to protect the cables from the sensors to the control unit. Conduit systems can channel water due to ingress and condensation directly to sensors and sensor connections which over time will adversely affect the performance of the system. As such, the installation of low point conduit drains is recommended for all sensors.

The Control Unit box should be installed in a suitable control or starter switch room and mounted at an eye level position so that the warning lights can be readily seen. The box should have sufficient space to open the lid for wiring and adjustment

! WARNING

The Control Unit is susceptible to static voltage. Connection of a clean ground to terminal 29 is essential for optimum performance. Prior to this connection, static handling precautions should be taken.

HARDWARE DESCRIPTION

The F500 is equipped with an RS232 and RS485 communications ports and a Fieldbus Ethernet port. The RS485 port is a four wire, twin twisted pair full duplex serial port and has been specifically configured to work with the T500. You should not connect any other devices to this port. The RS232 port has a standard D9-SUB connector and should be used for diagnostics and maintenance only. See Image A for communication port locations.

- System Components -**
1. Ethernet Port
 2. RS232 Port
 3. F500 Status LED
 4. RS485 Port
 5. Power / Alarm Terminal

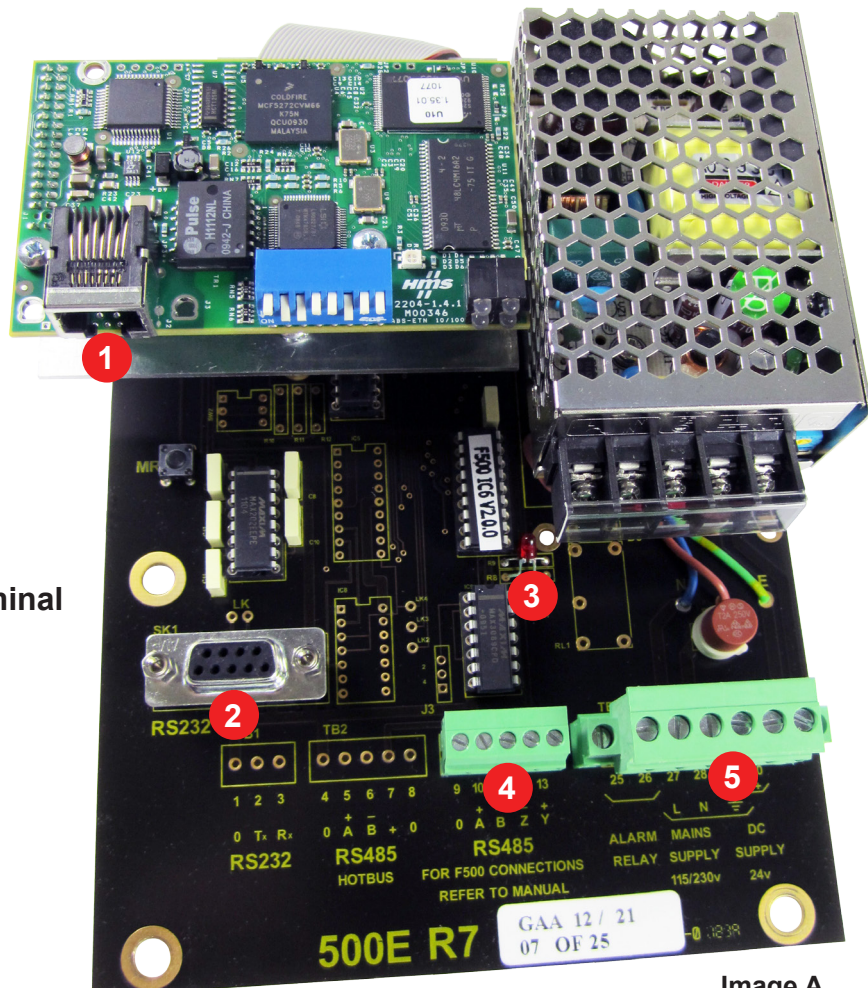

Image A

OPERATION DESCRIPTION

The F500 Fieldbus gateway has to be used together with the T500 controller. In order for the F500 to operate all the T500's (the F500 supports up to four) have to be correctly wired to the F500 and should have unique addresses as well as the total number of blocks preset. Please see the T500 manual for more information. Having finished this basic configuration it is necessary to cycle the power to the system for the F500 to go through the initialization procedure.

NOTE

Additional diagnostics information is available via the RS-232 DB9 connector during the initialization procedure. Please configure the serial port to 19200 baud, no parity, 8 data bits, 1 stop bit to view this.

ETHERNET SETTINGS SETUP

The Ethernet port is a standard 10/100 Base-T twisted pair Ethernet physical layer. The Ethernet module supports industry standard Modbus TCP protocols. The Fieldbus module should be connected through a standard Ethernet switch. Alternatively, a peer to peer connection could be made using a single crossover cable. The Fieldbus Ethernet module supports up to 16 simultaneous Ethernet connections. The F500 is shipped with the default Ethernet settings shown in the Table 1.

DEFAULT ETHERNET SETTINGS	
IP Address	192.168.0.x (Note Below)
Subnet Mask	255.255.255.0
Gateway Address	0.0.0.0
Modbus TCP Port Number	502

Table 1

NOTE

The last byte of the IP address "x" refers to the settings made on the switches located on the Ethernet module. The switch block contains 8 switches which represent the last address of the IP address 192.168.0.1-255. The right most switch (# 8) is the Least Significant Bit and the left most switch (# 1) is the Most Significant Bit of the address. The switch is considered on (selected) when in the down position. The F500 is supplied with a default switch setting for IP 192.168.0.100. Power must be cycled after the address has been changed. Please refer to Image B. To use a different subnet, see *Network Settings*.

The unit supports DHCP addressing, but it is advisable to use static IP address settings, as this makes the setup process simpler and the unit's address will never change. If the DHCP scheme is employed then a DHCP server must be present on the network. The process of configuring the DHCP settings via the F500-s website is described in the F500 e-View section. The RJ-45 connector complies with standard Ethernet RJ-45 connection scheme. Details are given in Table 2.

The Ethernet module has a bank of status LED's as shown in Image B. The statuses are explained in Table 3.

LED's 2 and 3 will flash together when the F500 is correctly initialized and connected to an Ethernet Switch. If only LED 2 is flashing, then the Ethernet module has not yet initialized or a connection has not yet been established.

The F500 is capable of providing data for up to 64 HOTBUS2 network nodes. Up to four T500 units can be connected to a single F500, providing that the total number of nodes does not exceed 64. Depending on the node type each node may hold different number of sensors. For example a TN4 node has 4 sensor inputs and an on-board node ambient temperature; SN2 however has two speed inputs. Please refer to the T500 manual for more information.

PIN #	NAME	DESCRIPTION
1	TD+	Positive Transmit Data
2	TD-	Negative Transmit Data
3	RD+	Positive Receive Data
4		No Connection
5		No Connection
6	RD-	Negative Receive Data
7		No Connection
8		No Connection
Casing	PE	Ground

Table 2 - Address Switch Settings

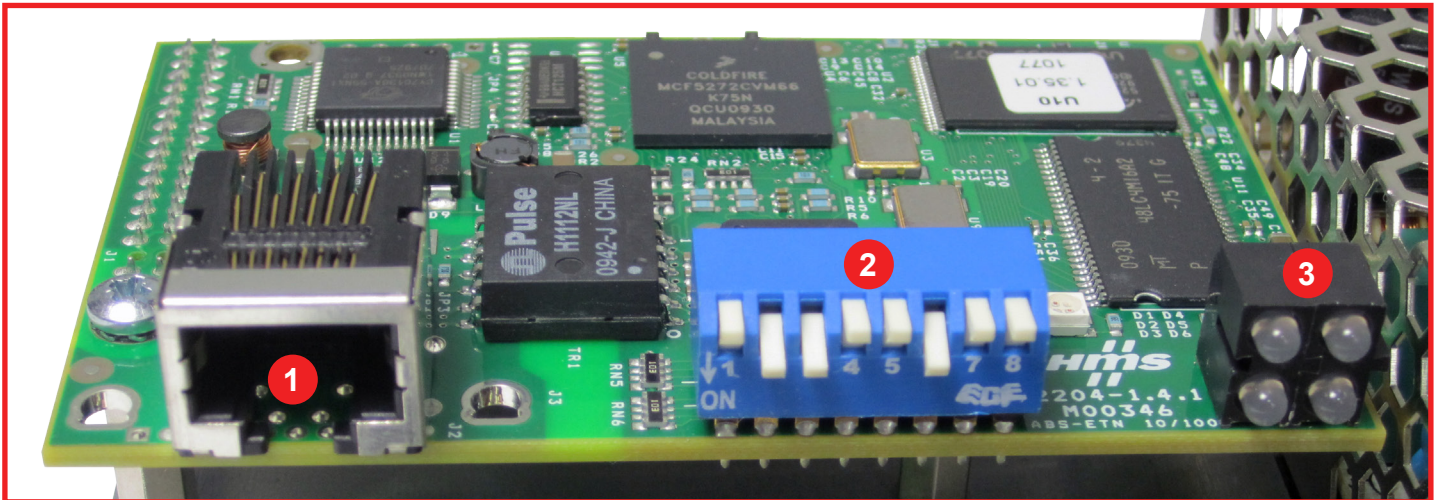
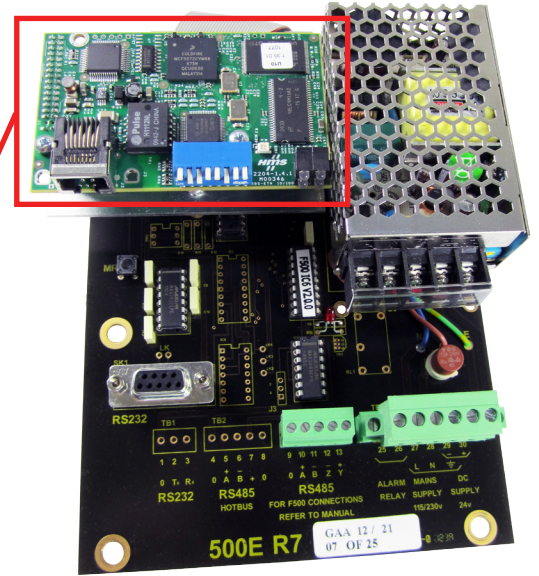
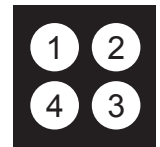

Image B

- Ethernet Module -**
1. Ethernet Connector
 2. Address Switch
 3. Status LED's



Status LED Numbers

STATUS LED NUMBERS	COLOR	DESCRIPTION
LED 1	Green - Solid	F500 Connected to Ethernet Network (Link)
LED 2	Green - Solid	Operating Normally
	Green - Flashing	Standby - Module Not Configured
	Red - Flashing	Minor Fault
	Red - Solid	Major Fault
	Red / Green - Flashing	Self Test in Progress
LED 3	Green - Flashing	Ethernet Connection Established
	Green - Solid	No Active Ethernet Connections
	Red - Flashing	Existing Ethernet Connection Timed Out, Power Cycle F500
	Red - Solid	Duplicate IP Address Detected, Change Address
	Red / Green - Flashing	Self Test in Progress
LED 4	Green - Flashing	Receiving & Transmitting Packets (Activity)

Table 3 - Status LED Descriptions

F500 eVIEW WEBSITE

Having configured the Ethernet connection the data can be extracted out of the F500. To read the data, type in the units IP address into an Internet browser on a PC that is on the same Ethernet network as the F500. The F500 eView webpage will load up and all the T500 system information will be displayed. An example is given below (Image C).





F500 eView -

Remote System Status Application for the
T500 Elite Hotbus™ Hazard Monitoring System

4B Components Ltd.
Morton, IL - USA



24 Hour Technical Support: (309) 698-5611

Live View
System Settings
Set Sensor Names
Network Settings
Set Email List
Support

F500 Unit Name: ANY PLANT USA

System State ⌵

Network #	Network Name	T500 Status	Number of Active Nodes / Blocks	Activity Counter
T500-1	LOAD OUT	Alarm	32 / 2	159
T500-2		Inactive	0 / 0	0
T500-3		Inactive	0 / 0	0
T500-4		Inactive	0 / 0	0

Detailed Node Information ⌵

Node #	Net #	Node Type	Sen #	T500 Sen#	Sensor Name	Sensor State	Sensor Value
▼ 1	T500-1	SN2					
○			1.1	1	WET LEG SPEED	Stopped	0 PPM
○			1.2	2	DRY LEG SPEED	Stopped	0 PPM
▼ 2	T500-1	TN4					
○			2.1	5	WETLEG HEAD W BRG	OK	82 °F
○			2.2	6	WETLEG HEAD E BRG	OK	82 °F
○			2.3	7	WETLEG HEAD W TS	OK	Contact Closed (ON)
○			2.4	8	WETLEG HEAD E TS	OK	Contact Closed (ON)
○			2.5		Ambient	OK	86 °F
▼ 3	T500-1	TN4					
○			3.1	9	WETLEG BOOT W BRG	Alarm	145 °F
○			2.2	6	WETLEG HEAD E BRG	OK	79 °F
○			2.3	7	WETLEG HEAD W TS	OK	Contact Closed (ON)
○			2.4	8	WETLEG HEAD E TS	Alarm	Contact Open (OFF)
○			2.5		Ambient	OK	86 °F
▼ 3	T500-1	TN4					
○			3.1	9	WETLEG BOOT W BRG	OK	86 °F
○			3.2	10	WETLEG BOOT E BRG	OK	82 °F
○			3.3	11	WETLEG BOOT W TS	OK	Contact Closed (ON)
○			3.4	12	WETLEG BOOT E TS	OK	Contact Closed (ON)
○			3.5		Ambient	OK	91 °F
▼ 4	T500-1	TN4					
○			4.1	13	DRYLEG HEAD W BRG	OK	77 °F
○			4.2	14	DRYLEG HEAD E BRG	OK	75 °F
○			4.3	15	DRYLEG HEAD W TS	OK	Contact Closed (ON)
○			4.4	16	DRYLEG HEAD E TS	OK	Contact Closed (ON)
○			4.5		Ambient	OK	84 °F
▼ 5	T500-1	TN4					
○			5.1	17	HMRMIL HEAD W BRG	OK	75 °F
○			5.2	18	HMRMIL HEAD E BRG	OK	73 °F
○			5.3	19		OK	Contact Open (OFF)
○			5.4	20		OK	Contact Open (OFF)
○			5.5		Ambient	OK	84 °F

Copyright 2012 4B Components Ltd. - All Rights Reserved

LIVE PAGE VIEW -

The eView Front Page is divided into a number of sections. At the top of the page there are the navigation buttons that allow the user to switch between the Live View page and other unit settings web pages which will be discussed later in the document.

The System State section gives a quick summary of how many T500 systems are connected to the F500 and how many nodes are active in each one. The system status of each T500 system is also displayed. The T500 statuses are displayed in the following manner, shown in Table 4.

STATUS DISPLAY	COLOR	DESCRIPTION
OK	Green	No Alarms Present on T500 Network
Alarm	Red	At Least One Sensor on T500 Network is in Alarm
Comms Lost!	Red	Communication Lost Between F500 and T500
Inactive	Grey	No T500 Found or T500 Address Set to Zero

Table 4 - T500 Status Descriptions

The system currently supports two types of nodes: TN4 (temperature node with four inputs) and SN2 (speed node with two inputs). This section is a drill through table type meaning that the information is displayed at two logical levels; the node level and the sensor level. The node level provides information about the node. The following information is available:

- Node Number – Node number within the T500 (1 to 64)
- Node Network – The T500 network that the node belongs to
- Node Type – TN4 or SN2

Depending on the node type the sensor level of that table is populated dynamically. The TN4 has four inputs and a node ambient temperature and therefore 5 rows are generated. The SN2 has only two inputs and so only two rows are generated. The following information is available for each sensor:

- Sen # – This is the system sensor number compiled by combining the node number with the input number, i.e. Input number 3 on node number 5 is displayed as 5.3
- T500 Sen # – This field is for backwards compatibility with the T500 on-module display. All sensors are listed as 1 to 256 within the T500. This is very helpful when cross-referencing between the two systems
- Sensor Name – This is a configurable field that allows you to name each sensor in the system, so that it can be easily cross-referenced to the plant documentation. Please see more information on this in *Set Sensor Names* section of this manual
- Sensor State – This field displays the current sensor state and is dependent on the node type that the sensor belongs to. This field is responsible for color coding the sensor row. Please see Table 5 for details.

TN4 NODE	STATE	COLOR	DESCRIPTION
	OK	Green	Sensor is Healthy
	Alarm	Red	Alarm Detected

SN2 NODE	STATE	COLOR	DESCRIPTION
	Stopped	Green	Machine Stopped
	Starting	Green	Machine Start Up Delay
	Running	Green	Machine Running Normally
	Interlock Off!	Green	Interlock Removed, Machine Still Running
	Calibrating	Green	SN2 Input Calibration in Progress
	Underspeed Alarm	Red	10% Underspeed Condition Detected
	Underspeed Stop	Red	20% Underspeed Condition Detected
	Comms Lost	Red	Lost Communication Between T500 and SN2 Node
Invalid	Green	Internal Fatal Error, Contact Technical Support	

Table 5 - TN4 & SN2 Node States

- Sensor Value – This field displays the currently sensed value. Depending on the node type and sensor configuration this may display different information. The TN4 and SN2 values are given in Table 6.

TN4 NODE	NTC SENSOR TYPE	
	Numerical Value	Current Sensor Temperature (°F or °C)
	NTC Open Circuit	Open Circuit - Temperature Sensor Failure
	NTC Short Circuit	Short Circuit - Temperature Sensor Failure
	NTC Over Range	Temperature Value Cannot be Calculated - Temperature Sensor Failure
	PTC SENSOR TYPE	
	PTC OK	PTC Sensor is OK (Cold)
	PTC Hot	PTC Sensor Tripped (Hot)
	CONTACT SENSOR TYPE	
	Contact Open (Off)	No Voltage Present on TN4 Input
	Contact Closed (On)	Voltage Present on TN4 Input
	COMMON VALUES	
	Comms Lost!	Lost Communication Between T500 and TN4 Node
Not Scanned	Node not Scanned by T500	
Invalid State	Internal Fatal Error, Contact Technical Support	
SN2 NODE	Numerical Value	Machine Speed in PPM (Pulses Per Minute)
	N/A	Machine Speed not Applicable

Table 6 - TN4 & SN2 Values

SYSTEM SETTINGS -

This part of the website allows the user to set a number of system parameters.

- F500 Unit/Location Name – This field allows the end user to give the unit a custom name. It is advisable to associate the unit name with its physical location
- T500-1 Network Name – These fields allow the end user to give custom names to the individual T500 networks (1 to 4)
- Temperature Display Units – This sets degree units for the display in the Live View page as well as in the email notification. However, it does not change the units on the T500.
- Time Zone Selection – This field allows the end user to select which time zone the unit is located in. This is very crucial for the email notifications to make sure the email server can use the correct time zone and correct time and date are displayed in the notification emails.
- Send Test Email – This link triggers the sending of a test email notification. This should be used to verify the email notification setup. Please see the *Email Notifications* section of this manual for more details.

For an example of the System Settings Page, see Image D.

F500 eView - Remote System Status Application for the T500 Elite Hotbus™ Hazard Monitoring System

4B Components Ltd. Morton, IL - USA
24 Hour Technical Support: (309) 698-5611

Powered by HazardMon.com

Live View System Settings Set Sensor Names Network Settings Set Email List Support

SYSTEM INFORMATION SETTINGS

Note: character ' : ' is not allowed in any fields!

F500 Unit/Location Name:

T500-1 Network Name:

T500-2 Network Name:

T500-3 Network Name:

T500-4 Network Name:

Temperature Display Units: Degrees C Degrees F

Time Zone Selection:

[Send a Test Email](#)

Copyright 2012 4B Components Ltd. - All Rights Reserved

Image D

SET SENSOR NAMES -

This page allows the end user to give custom names to the individual sensors on the system. The maximum allowed sensor name length is 16 characters. Sensor names for 8 nodes can be saved at one time. Please navigate through all the individual node ranges and save the appropriate sensor names page by page. Refer to Image E for an example of this page.

F500 eView -
Remote System Status Application for the
T500 Elite Hotbus™ Hazard Monitoring System

4B Components Ltd.
Morton, IL - USA
24 Hour Technical Support: (309) 698-5611

Live View System Settings **Set Sensor Names** Network Settings Set Email List Support

Select Sensor Range

1 to 8 9 to 16 17 to 24 25 to 32 33 to 40 41 to 48 49 to 56 57 to 64

SENSOR NAMES FOR NODES 1 to 8

Note: character ':' is not allowed in sensor names!

Sensor #	Sensor Name
1.1	<input type="text" value="sen_1"/>
1.2	<input type="text" value="sen_2"/>
1.3	<input type="text" value="sen_3"/>
1.4	<input type="text" value="sen_4"/>
2.1	<input type="text" value="sen_5"/>
2.2	<input type="text" value="sen_6"/>
2.3	<input type="text" value="sen_7"/>
2.4	<input type="text" value="sen_8"/>
3.1	<input type="text" value="sen_9"/>
3.2	<input type="text" value="sen_10"/>

Save Settings

Copyright 2012 4B Components Ltd. - All Rights Reserved

Image E

NETWORK SETTINGS -

This page provides in-depth diagnostics as well as allows setting advanced configuration parameters, see Image F. The information like the unit's serial number, F500 firmware version, eView website version and Ethernet interface information is available to view in the first section of this web page. This section can be very helpful when contacting 4B technical support.

The second section of this web page allows the user to change the Network Connection Settings. All the standard IP settings are given here, including the ability to enable the DHCP.

The third section of this web page provides the ability to change the email notification server settings. The unit is shipped with the following default settings which should not be changed unless problems arise during the installation.

- SMTP Server Address: **smtp.hazardmon.com**
- SMTP Port Number: **25** (The hazardmon.com server also supports port 3001, this can be used if port 25 is being blocked by your firewall or Internet service provider)
- SMTP User Name: **f500-plus**
- SMTP Password: **left blank**

These settings may be changed if the customer wishes to use their own email server to send the email notifications. This is an advanced feature and should only be used by IT professionals.

NOTE

Any changes to the data on the *Network Settings* page requires the unit to be power cycled before the new settings take effect. Make sure all the Ethernet IP address switches on the F500 module are set to OFF state before proceeding. Alternatively the switches will override these settings. Please refer to *Appendix 4 - Ethernet IP Address Switch Settings* for more information.



F500 eView - Remote System Status Application for the T500 Elite Hotbus™ Hazard Monitoring System

Powered by
azardMon.com

4B Components Ltd.
Morton, IL - USA



24 Hour Technical Support: (309) 698-5611

Live View

System Settings

Set Sensor Names

Network Settings

Set Email List

Support

NETWORK CONFIGURATION SETTINGS

Unit Information

F500 PLUS Serial Number:

F500 PLUS Firmware Version:

Website Version:

Ethernet Interface Serial Number:

Ethernet Interface Firmware Version:

Ethernet Interface Bootloader Version:

Network Connection Settings

Use DHCP:

IP Address:

Please make sure all the IP Address switches are in the OFF state on the F500 unit for the IP address and DHCP fields to become active. The switches override the settings above!

Subnet Mask:

Gateway Address:

DNS Address:

Alternative DNS Address:

Domain Name:

HOST Name:

Email Server Settings (used only for sending alarm change notification emails)

SMTP Server Address:

SMTP Port Number:

SMTP Server Username:

SMTP Server Password:

Please make sure that password field is not left blank if authentication is used! Leave blank otherwise.

Save Settings

Copyright 2012 4B Components Ltd. - All Rights Reserved

Image F

SET EMAIL LIST -

This page allows the end user to enter the email addresses that they require the email notifications to be sent to. Up to 10 email addresses are currently supported. At least one valid email address should be entered here for the notification system to become active.

This page also allows the end user to provide an external IP address for the system, so that the eView website could be accessed from the internet (outside the facility). This would usually be the Facility's main IP address with some custom port number. In order to use this feature a firewall rule will need to be created on the Facility's main internet router, that would allow the custom port to be routed to port 80 (HTTP) and internal IP address of the F500. As every router is different, it is impossible to provide step-by-step instructions for all the possible variations.

Please contact 4B technical support if more information is required.

SUPPORT LINK -

This button will open a new tab/window of the internet browser used and lead the user to additional support information on the manufacturer's website.

EMAIL NOTIFICATIONS -

The F500 unit comes with an in-built email notification engine. This feature allows keeping record of all the alarms that are raised by the sensors and also notifies the recipients in the email list instantly.

All that is needed to use email notifications is to make sure that the F500 has been given a valid IP Address, (see *Network Settings* page) and at least one email address in the *Set Email List* page (see *Set Email List* page). Once the system has been configured, generate a test email to verify the configuration. Please refer to the *System Settings* page for more information.

There are three notification types that the F500 is able to generate:

- Power Up Event – An email is sent out every time the F500 unit is powered up to notify the recipients that it has been powered down previously
- Test Email – A test email that is used to verify the F500 email notifications setup. More information is available on the *System Settings* Page.
- Alarm Change Event – An email is sent out every time a sensor either goes in or out of alarm. This email provides information on which sensors changed state, what the current state is and what the previous state was. It also has a table of all sensors that are in alarm, which is very useful for large systems with many sensors.

F500 PLC DATA ACCESS - MODBUS TCP / ETHERNET IP

The F500 Fieldbus Adapter supports two main PLC protocols - Modbus TCP and Ethernet IP. Only Modbus TCP is covered in this manual as it is most commonly used. For information on Ethernet IP protocol (mainly used with Rockwell PLCs) and more in-depth information on Modbus TCP as well application notes on how to configure the PLC, contact 4B.

MODBUS TCP CONNECTION SETTINGS -

The F500 unit supports the following Modbus connection settings:

NAME	VALUE	DESCRIPTION
Port Number	502	Standard Modbus TCP Port
Slave ID	1	----
Supported Functions	03 - Read Holding Registers	Allows PLC to Read Data from F500, see <i>F500 Data Storage Table</i>
Supported Address Range	0 to 220	Word Address Range for 03 Function Code (16 bit)
Alarm Acknowledge Words Addresses	1023, 1024	Alarm Acknowledge Words

Table 7

T500 BLOCKS -

When T500's are connected to the F500 it is necessary to set up the communication address and block number settings within the T500's beforehand (see T500 manual for details). Each T500 must have a unique non-zero communication address. The number of blocks field relates to the number of nodes each T500 reports to the F500. Each block contains 16 nodes. As the total number of nodes should not exceed 64, the total number of blocks within all the connected T500's should not exceed 4. Table 8 illustrates some of the possible configurations. The minimum system is one T500 connected to one F500 and monitoring one block of sensor data (16 nodes).

T500-1 BLOCKS	T500-2 BLOCKS	T500-3 BLOCKS	T500-4 BLOCKS	TOTAL NODES
1	0	0	0	16
1	1	0	0	32
1	1	1	0	48
1	1	1	1	64
1	2	1	0	64
2	2	0	0	64
2	1	1	0	64
1	1	2	0	64
0	1	0	1	32
0	0	1	1	32
0	0	0	1	16
4	0	0	0	64
0	4	0	0	64
3	1	0	0	64
1	0	3	0	64
0	0	0	4	64

Table 8

F500 DATA STORAGE TABLE -

MODBUS DATA WORD #	FIELD NAME	DESCRIPTION
0	T500 #1 Number of Active Blocks	Can Take Values of 0 to 4
1	T500 #1 Activity Counter	Increments Every Time T500 Data is Gathered
2	T500 #2 Number of Active Blocks	Can Take Values of 0 to 4
3	T500 #2 Activity Counter	Increments Every Time T500 Data is Gathered
4	T500 #3 Number of Active Blocks	Can Take Values of 0 to 4
5	T500 #3 Activity Counter	Increments Every Time T500 Data is Gathered
6	T500 #4 Number of Active Blocks	Can Take Values of 0 to 4
7	T500 #4 Activity Counter	Increments Every Time T500 Data is Gathered
8	F500 Fault Code	0 - No Faults Detected 1 - Total Blocks Detected is 0 2 - Total Blocks Greater Than 4 (Over 64 Nodes) 3 - One or More T500's Set to DeviceNet 4 to 255 - Not Used
9	Not Used	N/A
10	Block 1, Node 1, Bytes 1 and 2	Sensor Data (S1 – MSB; S2 – LSB)
11	Block 1, Node 1, Bytes 3 and 4	Sensor Data (S3 – MSB; S4 – LSB)
12	Block 1, Node 2, Bytes 1 and 2	Sensor Data (S1 – MSB; S2 – LSB)
13	Block 1, Node 2, Bytes 3 and 4	Sensor Data (S3 – MSB; S4 – LSB)
...
40	Block 1, Node 16 Bytes 1 and 2	Sensor Data (S1 – MSB; S2 – LSB)
41	Block 1, Node 16, Bytes 3 and 4	Sensor Data (S3 – MSB; S4 – LSB)
42	Block 2, Node 1, Bytes 1 and 2	Sensor Data (S1 – MSB; S2 – LSB)
43	Block 2, Node 1, Bytes 3 and 4	Sensor Data (S3 – MSB; S4 – LSB)
...
72	Block 2, Node 16, Bytes 1 and 2	Sensor Data (S1 – MSB; S2 – LSB)
73	Block 2, Node 16, Bytes 3 and 4	Sensor Data (S3 – MSB; S4 – LSB)
74	Block 3, Node 1, Bytes 1 and 2	Sensor Data (S1 – MSB; S2 – LSB)
75	Block 3, Node 1, Bytes 3 and 4	Sensor Data (S3 – MSB; S4 – LSB)
...
104	Block 3, Node 16, Bytes 1 and 2	Sensor Data (S1 – MSB; S2 – LSB)
105	Block 3, Node 16, Bytes 3 and 4	Sensor Data (S3 – MSB; S4 – LSB)
106	Block 4, Node 1, Bytes 1 and 2	Sensor Data (S1 – MSB; S2 – LSB)
107	Block 4, Node 1, Bytes 3 and 4	Sensor Data (S3 – MSB; S4 – LSB)
...
136	Block 4, Node 16, Bytes 1 and 2	Sensor Data (S1 – MSB; S2 – LSB)
137	Block 4, Node 16, Bytes 3 and 4	Sensor Data (S3 – MSB; S4 – LSB)
138	Not Used	N/A
139	Not Used	N/A
140	Block 1, Node 1 and Node 2 Status/ Ambient Temperature	Node Status Data (A1 – MSB; A2 – LSB)
...

MODBUS DATA WORD #	FIELD NAME	DESCRIPTION
147	Block 1, Node 15 and Node 16 Status/ Ambient Temperature	Node Status Data (A15 – MSB; A16 – LSB)
148	Block 2, Node 1 and Node 2 Status/ Ambient Temperature	Node Status Data (A1 – MSB; A2 – LSB)
...
155	Block 2, Node 15 and Node 16 Status / Ambient Temperature	Node Status Data (A15 – MSB; A16 – LSB)
156	Block 3, Node 1 and Node 2 Status/ Ambient Temperature	Node Status Data (A1 – MSB; A2 – LSB)
...
163	Block 3, Node 15 and Node 16 Status / Ambient Temperature	Node Status Data (A15 – MSB; A16 – LSB)
164	Block 4, Node 1 and Node 2 Status/ Ambient Temperature	Node Status Data (A1 – MSB; A2 – LSB)
...
171	Block 4, Node 15 and Node 16 Status / Ambient Temperature	Node Status Data (A15 – MSB; A16 – LSB)
172 - 178	Not Used	N/A
179	T500 #1 and T500 #2 Alarm	T500 Alarm (T500 #1 – MSB; T500 #2 – LSB)
180	T500 #3 and T500 #4 Alarm	T500 Alarm (T500 #3 – MSB; T500 #4 – LSB)
181 - 184	Not Used	N/A
185	Node Alarms Bytes 1 and 2	Individual Sensor Alarm Information
...
200	Node Alarms Bytes 31 and 32	Individual Sensor Alarm Information
201 - 204	Not Used	N/A
205	Node Type Bytes 1 and 2	Individual Sensor Type Information
...
220	Node Type Bytes 31 and 32	Individual Sensor Type Information

Table 9

Abbreviations:

Most Significant Byte (MSB)

Least Significant Byte (LSB)

SYSTEM INFORMATION (WORD 0 TO 9) -

- Number of Active Block (T500-1 to T500-4) - This field provides the information on the number of blocks configured within each of the four T500-s. It can take values of 0 to 4
- Activity Counter - This field provides means of checking if the communication between the F500 and each T500 is active. This field will increment by 1 every time new data has been successfully received from the T500. The value will increment from 0 to 255 and then roll over back to 0. Depending on the system size, it may take up to 8 seconds for this value to update. It is recommended that the operator be alerted if the value has not been updated for 15 seconds.
- F500 Fault Code - This field gives the current F500 Fault State. Please refer to Table 9 for more information

NODE TYPES (WORD 205 TO 220) -

The F500 and T500 support multiple types of communication nodes - TN4 and SN2. The sensor data is encoded differently depending on the node type. Therefore it is crucial to know what the current node type is before decoding the sensor data (Table 11).

The information for all 64 node types is stored in 16 Words or 32 Bytes. Each node requires 4 bits to store its type. This means that each word contains information for 4 nodes. Table 10 below describes the data alignment.

WORD 205			
Bits 15:12	Bits 11:8	Bits 7:4	Bits 3:0
Node 2	Node 1	Node 4	Node 3
WORD 206			
Bits 15:12	Bits 11:8	Bits 7:4	Bits 3:0
Node 6	Node 5	Node 8	Node 7
...			
WORD 220			
Bits 15:12	Bits 11:8	Bits 7:4	Bits 3:0
Node 62	Node 61	Node 64	Node 63

Table 10

Supported Node Types:

VALUE	NODE TYPE
0	Not Scanned
1	TN4
2	SN2

Table 11

SENSOR ALARMS (WORD 185 TO 200) -

This section provides information on whether each individual sensor is in alarm or not. This is the absolute minimum that is required by the PLC to successfully decode the sensor state to alarm or healthy.

The information for all 64 node alarms is stored in 16 words or 32 bytes. Each node can have up to 4 sensors and therefore requires 4 bits to store the alarms. This means that each word stored contains information for alarms on 4 nodes. Table 12 below describes the data alignment.

WORD 185			
Bits 15:12	Bits 11:8	Bits 7:4	Bits 3:0
Node 2	Node 1	Node 4	Node 3
WORD 186			
Bits 15:12	Bits 11:8	Bits 7:4	Bits 3:0
Node 6	Node 5	Node 8	Node 7
...			
WORD 200			
Bits 15:12	Bits 11:8	Bits 7:4	Bits 3:0
Node 62	Node 61	Node 64	Node 63

Table 12

The individual sensor alarm bits within each node have different meaning depending on the node type. The decoding is shown in Table 13. If the bit reads 1, then the input is in alarm. If the bit reads 0 then the input is not in alarm.

TN4			
Bit 3	Bit 2	Bit 1	Bit 0
Sensor 4	Sensor 3	Sensor 2	Sensor 1
SN2			
Bit 3	Bit 2	Bit 1	Bit 0
Input 2 - Underspeed Alarm	Input 2 - Underspeed Stop	Input 1 - Underspeed Alarm	Input 1 - Underspeed Stop

Table 13

SENSOR DATA (WORD 10 TO 137) -

Each node takes up two words of information. Depending on the node type, the meaning of the data in these two words changes. Having determined the node type (Table 11), it is possible to decode the data for individual sensors.

TN4 SENSOR DATA DECODING -

If the node type is TN4 then each node has four sensors. Each sensor occupies one byte and the data is aligned in the following manner shown in Table 14.

WORD 10		WORD 11	
Most Significant Byte	Least Significant Byte	Most Significant Byte	Least Significant Byte
Sensor 1	Sensor 2	Sensor 3	Sensor 4

Table 14

Each sensor byte should then be decoded as shown in Table 15.

VALUE (DECIMAL)	VALUE (HEX)	DESCRIPTION
0 to 110	0x00 to 0x6E	NTC Positive Temperature (0°C to 110°C)
127 to 158	0x7F to 0x9E	NTC Negative Temperature (-0°C to -31°C) *
238	0xEE	NTC Sensor Open Circuit
239	0xEF	Lost Communication Between T500 and Node
240	0xF0	PTC Sensor Healthy / Cold
241	0XF1	PTC Sensor Tripped / Hot
250	0xFA	Contact Sensor Open / OFF
251	0xFB	Contact Sensor Closed / ON
253	0XFD	Sensor Not Scanned by T500
254	0XFE	NTC Sensor Over Temperature Fault, Temperature Cannot be Measured Reliably
255	0XFF	NTC Sensor Short Circuit

Table 15

* For negative temperatures equation 1 should be used to convert values in the range of 127-158 to negative temperature:

- Equation 1: $t [^{\circ}\text{C}] = 127 - \text{Value (Decimal)}$

The temperatures are always reported in °C regardless of the display units on the T500. The PLC program has to convert the units into °F if required. Please use equation 2 for the conversion.

- Equation 2: $t [^{\circ}\text{F}] = (t [^{\circ}\text{C}] \times 1.8) + 32$

SN2 SENSOR DATA DECODING -

The SN2 node has two speed and two interlock inputs. The interlock inputs are used together with speed values to create SN2 input states which are described in the *Node State / Ambient Temperature Section (Word 140 to 171)*. The four bytes of sensor data is used for reporting the two machine speeds in pulses per minute (PPM). Two bytes are used for each speed input. The speed data decoding is illustrated below in Table 16.

WORD 10		WORD 11	
Most Significant Byte	Least Significant Byte	Most Significant Byte	Least Significant Byte
Speed Input 1	Speed Input 1	Speed Input 2	Speed Input 2

Table 16

NOTE: When using a four pulse Whirligig®, this will be four times the RPM. You can display RPM by dividing PPM by four.

NODE STATE / AMBIENT TEMPERATURE SECTION (WORD 140 TO 171) -

Depending on the node type this section of data should either be decoded as node ambient temperature for TN4 or Input Statuses for SN2. This section occupies 32 Words or 64 Bytes of data. This means that each node is allocated with a byte of data. See Table 17 for node allocation information.

WORD 140	
Most Significant Byte	Least Significant Byte
Node 1	Node 2
WORD 141	
Most Significant Byte	Least Significant Byte
Node 3	Node 4
...	
WORD 171	
Most Significant Byte	Least Significant Byte
Node 63	Node 64

Table 17

TN4 NODE AMBIENT DECODING -

For the TN4 node type the data in this section represents the node ambient temperature in °C. This data should be decoded as shown in Table 15, equations 1 and 2.

SN2 INPUT STATUS DECODING -

For the SN2 node type the data in this section represents detailed individual input statuses. Each byte contains information for two inputs. Each input status is 4 bits long. See Table 18 below for more information.

WORD 140			
Bits 15:12	Bits 11:8	Bits 7:4	Bits 3:0
Node 1, Input 2	Node 1, Input 1	Node 2, Input 2	Node 2, Input 1
WORD 141			
Bits 15:12	Bits 11:8	Bits 7:4	Bits 3:0
Node 3, Input 2	Node 3, Input 1	Node 4, Input 2	Node 4, Input 1
...			
WORD 171			
Bits 15:12	Bits 11:8	Bits 7:4	Bits 3:0
Node 63, Input 2	Node 63, Input 1	Node 64, Input 2	Node 64, Input 1

Table 18

Each input state should be decoded as stated below in Table 19.

VALUE (DECIMAL)	STATE	DESCRIPTION
0	Invalid	Invalid State
1	Stopped	Machine Stopped
2	Starting	Machine Start Up Delay
3	Running	Machine Running Normally
4	Interlock Off	Interlock Removed, Machine Still Running
5	Underspeed Alarm	10% Underspeed Condition Detected
6	Underspeed Stop	20% Underspeed Condition Detected
7	Calibrating	SN2 Input Calibration in Progress
8 - 14	Invalid	Reserved for Future Use
15	Comms Lost!	Lost Communication Between T500 and SN2 Node

Table 19

REMOTE ALARM ACKNOWLEDGEMENT -

The T500 has the ability to acknowledge the current alarm state by pressing the SET button on the T500 module. The warning relay is then turned back to the healthy state until either a relay re-activation time has elapsed or a new alarm has been detected. It may not always be convenient to go through the process if the T500 is mounted far away from the control room. Alternatively some PLC/SCADA programmers may want to achieve higher integration of the T500 system with their program. For these reasons the F500 supports the remote alarm acknowledgement functionality.

Words 179 and 180 as shown in Figure 19 contain T500 Unit alarm states for all the possible four T500-s that can be connected to the F500. The data allocation is shown below in Table 20.

WORD 179	
Most Significant Byte	Least Significant Byte
T500 #1 Alarm	T500 #2 Alarm
WORD 180	
Most Significant Byte	Least Significant Byte
T500 #3 Alarm	T500 #3 Alarm

Table 20

Each T500 field can contain two values (in hexadecimal):

- 0x00 - No alarms detected on this T500 network
- 0xFF - At least one alarm detected on this T500 network

Two alarm acknowledgement words (word 1023 and word 1024) are allocated in the F500 memory table that (unlike the rest of the data) are read/write, so that the user application can write into these locations as well as read from them. Write 0xFF into the appropriate byte to acknowledge the alarm. Once acknowledged, write 0x00 to return to normal operation. Table 21 displays the data allocation for alarm acknowledgement.

WORD 1023	
Most Significant Byte	Least Significant Byte
T500 #1 Alarm Acknowledge	T500 #2 Alarm Acknowledge
WORD 1024	
Most Significant Byte	Least Significant Byte
T500 #3 Alarm Acknowledge	T500 #3 Alarm Acknowledge

Table 21

THE ALARM ACKNOWLEDGEMENT PROCESS -

Below is a diagram that illustrates the steps that are required to adhere to in order to perform a remote alarm acknowledgement.

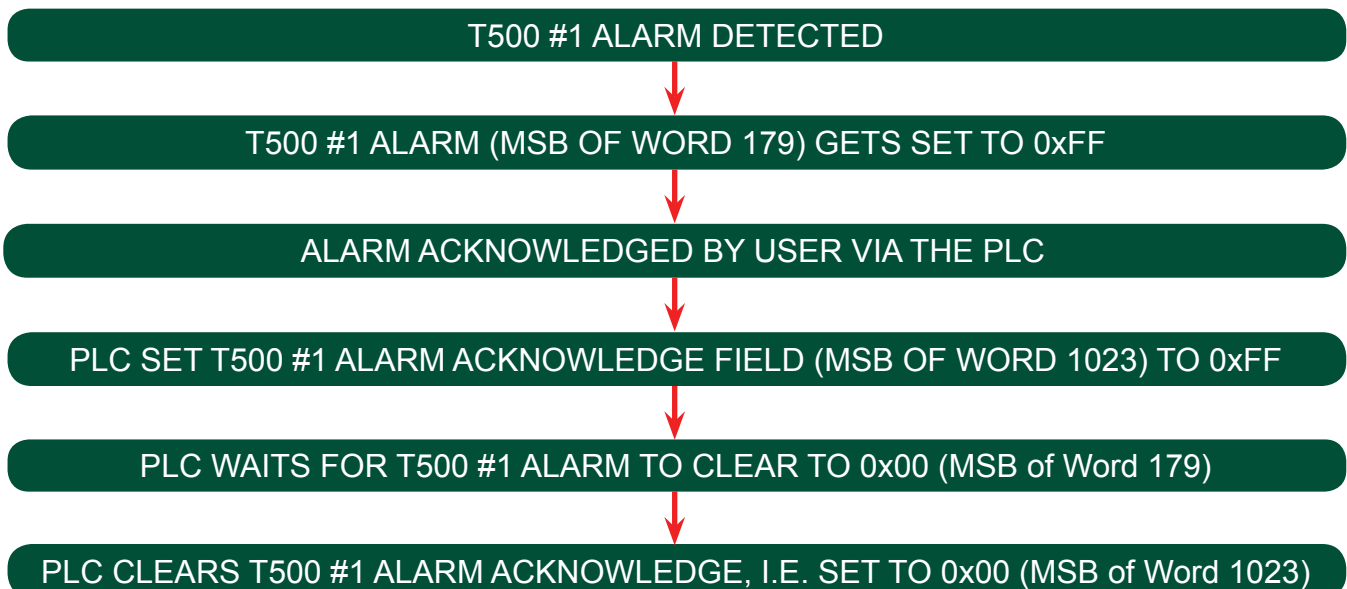

TROUBLESHOOTING GUIDE

FAULT	REMEDY
After Initial Start Up, F500 Status LED (Image A) is Flashing Red or Solid Red for Several Minutes	<ol style="list-style-type: none">1. Make sure wiring for F500 has been routed away from power cables.2. Make sure F500 is properly grounded.3. Check that high powered two-way radios are not being operated near the T500 or F500 as this will affect performance.4. Check that communications / power cable is connected correctly (Appendix 2 and 3).5. Ensure the T500 Fieldbus settings are correct.
Excessive Interference on Power Supply	Power conditioners and surge suppressors may have to be installed.
Control Unit is Overheating	Mount the unit in a temperature controlled room with a maximum temperature of 113° F (45°C).
T500 is not Responding or Intermittent Signals	Check that the 120 Ohm termination resistors are installed correctly.

NOTE

After any changes are made to the network or F500, you must re-start the F500 in order for the changes to be applied.

APPENDIX 1

SUPPLY VOLTAGE WIRING (120 to 240 VAC)

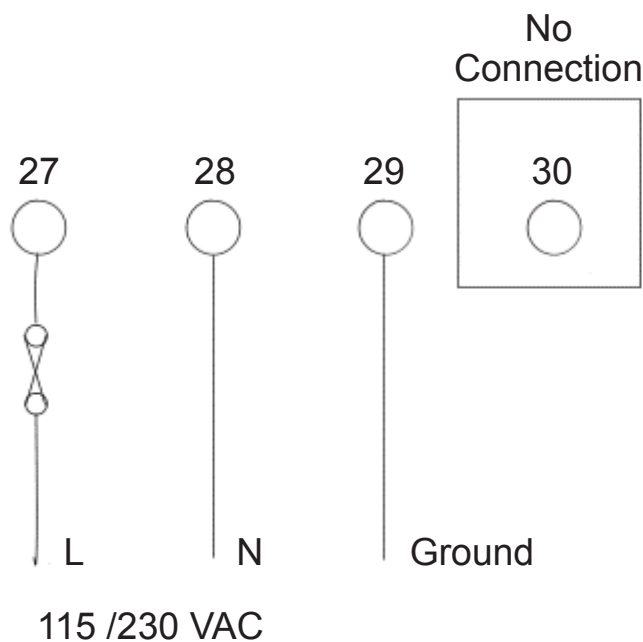

SUPPLY VOLTAGE WIRING (24 VDC)

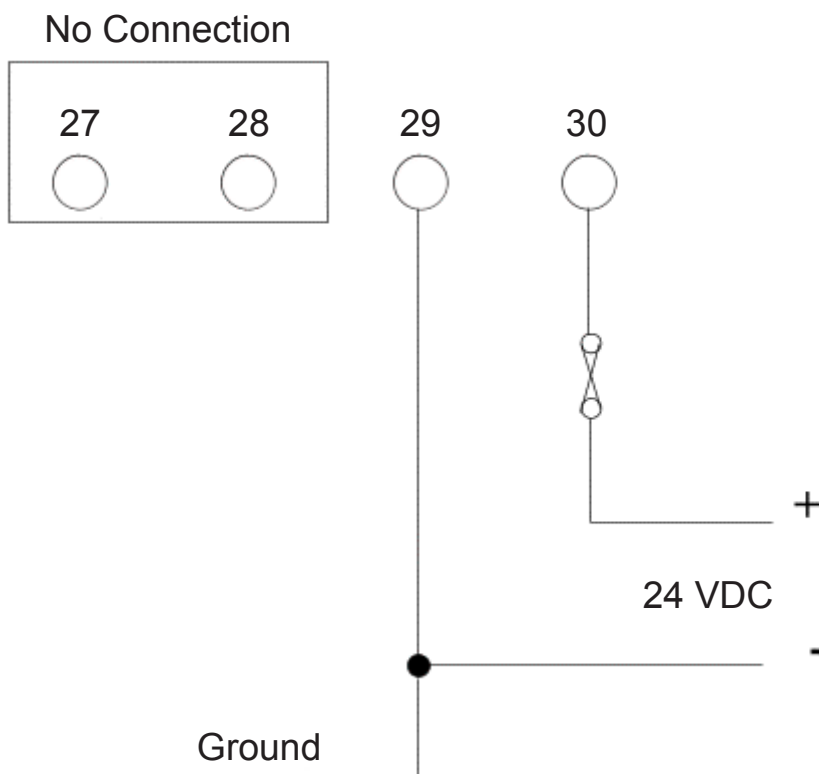

APPENDIX 2

T500 ELITE TO F500 ELITE CONNECTION DIAGRAM

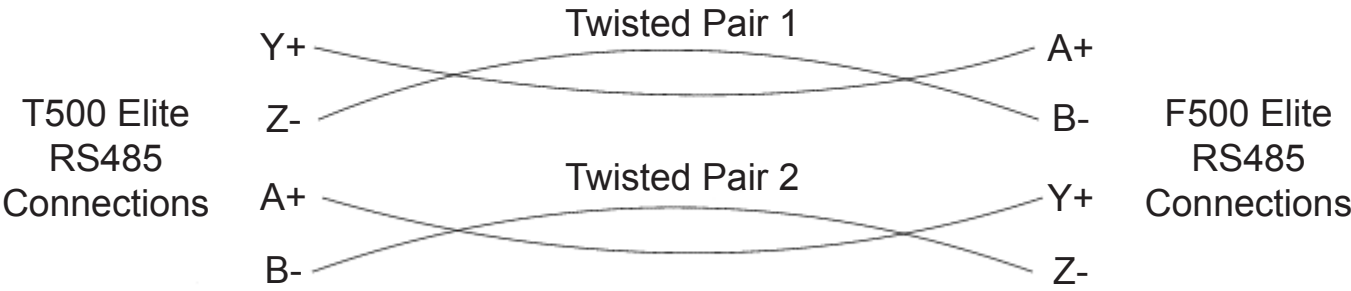
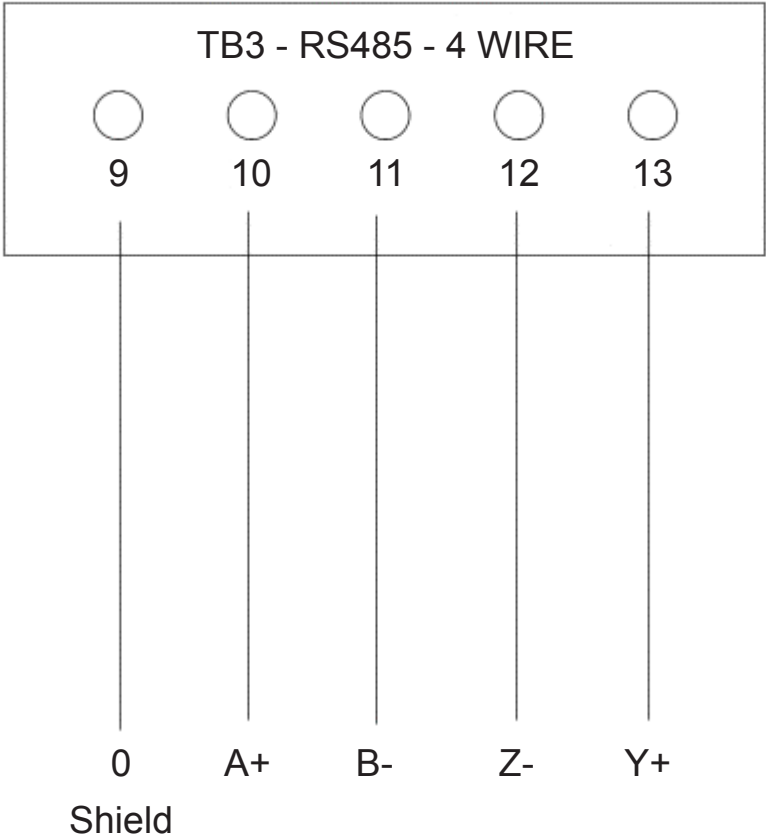

APPENDIX 3

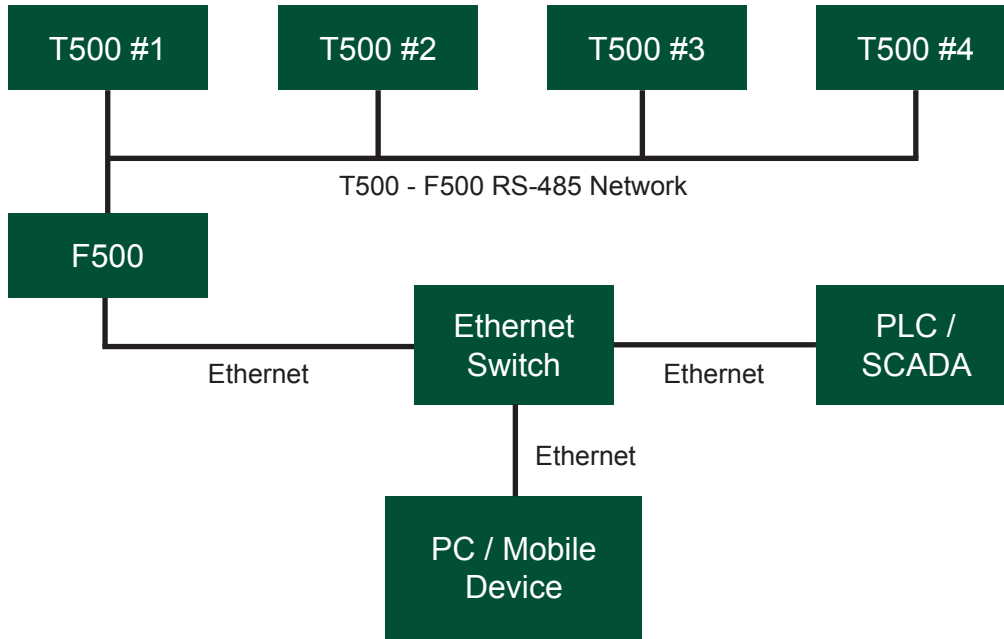

General Connection Detail For T500 Elite to F500 Elite

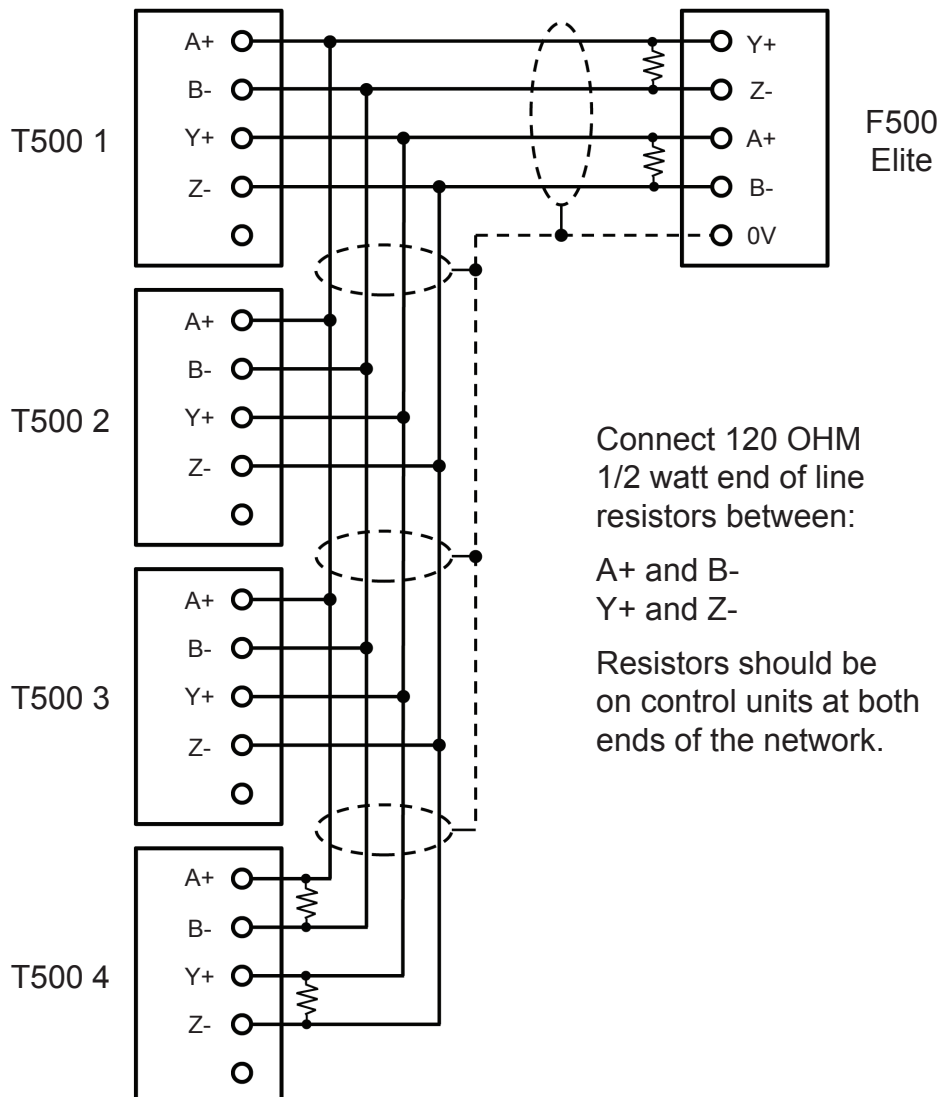

APPENDIX 4

ETHERNET IP ADDRESS SWITCH SETTINGS -

The table below represents the settings for the Ethernet address switches of the F500 as described in Table 2. The F500 is supplied with a default IP address of 192.168.0.100. The last three numbers of the address can be changed to give the F500 a unique address. The switches are numbered 1 to 8 left to right. Switch 8 represents the lowest binary number. In the table below a '0' represents the switch in the OFF or UP position and a '1' represents the switch in the DOWN or ON position. The table is made up in the following format:

ABC 12345678

Where ABC is the last part of the IP address 192.168.0.ABC and 12345678 represents the switch number from left to right.

NOTE

All switches must be up (off) to program the IP address from the web interface (see *Network Settings*).

The factory default setting is highlighted in yellow on the table below.

001	00000001	033	00100001	065	01000001	097	01100001
002	00000010	034	00100010	066	01000010	098	01100010
003	00000011	035	00100011	067	01000011	099	01100011
004	00000100	036	00100100	068	01000100	100	01100100
005	00000101	037	00100101	069	01000101	101	01100101
006	00000110	038	00100110	070	01000110	102	01100110
007	00000111	039	00100111	071	01000111	103	01100111
008	00001000	040	00101000	072	01001000	104	01101000
009	00001001	041	00101001	073	01001001	105	01101001
010	00001010	042	00101010	074	01001010	106	01101010
011	00001011	043	00101011	075	01001011	107	01101011
012	00001100	044	00101100	076	01001100	108	01101100
013	00001101	045	00101101	077	01001101	109	01101101
014	00001110	046	00101110	078	01001110	110	01101110
015	00001111	047	00101111	079	01001111	111	01101111
016	00010000	048	00110000	080	01010000	112	01110000
017	00010001	049	00110001	081	01010001	113	01110001
018	00010010	050	00110010	082	01010010	114	01110010
019	00010011	051	00110011	083	01010011	115	01110011
020	00010100	052	00110100	084	01010100	116	01110100
021	00010101	053	00110101	085	01010101	117	01110101
022	00010110	054	00110110	086	01010110	118	01110110
023	00010111	055	00110111	087	01010111	119	01110111
024	00011000	056	00111000	088	01011000	120	01111000
025	00011001	057	00111001	089	01011001	121	01111001
026	00011010	058	00111010	090	01011010	122	01111010
027	00011011	059	00111011	091	01011011	123	01111011
028	00011100	060	00111100	092	01011100	124	01111100

029	00011101	061	00111101	093	01011101	125	01111101
030	00011110	062	00111110	094	01011110	126	01111110
031	00011111	063	00111111	095	01011111	127	01111111
032	00100000	064	01000000	096	01100000	128	10000000
129	10000001	161	10100001	193	11000001	225	11100001
130	10000010	162	10100010	194	11000010	226	11100010
131	10000011	163	10100011	195	11000011	227	11100011
132	10000100	164	10100100	196	11000100	228	11100100
133	10000101	165	10100101	197	11000101	229	11100101
134	10000110	166	10100110	198	11000110	230	11100110
135	10000111	167	10100111	199	11000111	231	11100111
136	10001000	168	10101000	200	11001000	232	11101000
137	10001001	169	10101001	201	11001001	233	11101001
138	10001010	170	10101010	202	11001010	234	11101010
139	10001011	171	10101011	203	11001011	235	11101011
140	10001100	172	10101100	204	11001100	236	11101100
141	10001101	173	10101101	205	11001101	237	11101101
142	10001110	174	10101110	206	11001110	238	11101110
143	10001111	175	10101111	207	11001111	239	11101111
144	10010000	176	10110000	208	11010000	240	11110000
145	10010001	177	10110001	209	11010001	241	11110001
146	10010010	178	10110010	210	11010010	242	11110010
147	10010011	179	10110011	211	11010011	243	11110011
148	10010100	180	10110100	212	11010100	244	11110100
149	10010101	181	10110101	213	11010101	245	11110101
150	10010110	182	10110110	214	11010110	246	11110110
151	10010111	183	10110111	215	11010111	247	11110111
152	10011000	184	10111000	216	11011000	248	11111000
153	10011001	185	10111001	217	11011001	249	11111001
154	10011010	186	10111010	218	11011010	250	11111010
155	10011011	187	10111011	219	11011011	251	11111011
156	10011100	188	10111100	220	11011100	252	11111100
157	10011101	189	10111101	221	11011101	253	11111101
158	10011110	190	10111110	222	11011110	254	11111110
159	10011111	191	10111111	223	11011111	255	11111111
160	10100000	192	11000000	224	11100000		

PRODUCT WARRANTY

1. EXCLUSIVE WRITTEN LIMITED WARRANTY

ALL PRODUCTS SOLD ARE WARRANTED BY THE COMPANY (4B COMPONENTS LIMITED, (4B) BRAIME ELEVATOR COMPONENTS LIMITED, AND (4B) S.E.T.E.M. Srl) HEREIN AFTER REFERRED TO AS 4B TO THE ORIGINAL PURCHASER AGAINST DEFECTS IN WORKMANSHIP OR MATERIALS UNDER NORMAL USE FOR ONE (1) YEAR AFTER DATE OF PURCHASE FROM 4B. ANY PRODUCT DETERMINED BY 4B AT ITS SOLE DISCRETION TO BE DEFECTIVE IN MATERIAL OR WORKMANSHIP AND RETURNED TO A 4B BRANCH OR AUTHORIZED SERVICE LOCATION, AS 4B DESIGNATES, SHIPPING COSTS PREPAID, WILL BE, AS THE EXCLUSIVE REMEDY, REPAIRED OR REPLACED AT 4B'S OPTION.

2. DISCLAIMER OF IMPLIED WARRANTY

NO WARRANTY OR AFFIRMATION OF FACT, EXPRESSED OR IMPLIED, OTHER THAN AS SET FORTH IN THE EXCLUSIVE WRITTEN LIMITED WARRANTY STATEMENT ABOVE IS MADE OR AUTHORIZED BY 4B. 4B SPECIFICALLY DISCLAIMS ANY LIABILITY FOR PRODUCT DEFECT CLAIMS THAT ARE DUE TO PRODUCT MISUSE, ABUSE OR MISAPPLICATIONS, AS AUTHORIZED BY LAW, 4B SPECIFICALLY DISCLAIMS ALL WARRANTIES THAT THE PRODUCT IS FIT OR MERCHANTABLE FOR A PARTICULAR PURPOSE.

3. NO WARRANTY "BY SAMPLE OR EXAMPLE"

ALTHOUGH 4B HAS USED REASONABLE EFFORTS TO ACCURATELY ILLUSTRATE AND DESCRIBE THE PRODUCTS IN ITS CATALOGS, LITERATURE, AND WEBSITES, SUCH ILLUSTRATIONS AND DESCRIPTIONS ARE FOR THE SOLE PURPOSE OF PRODUCT IDENTIFICATION AND DO NOT EXPRESS OR IMPLY A WARRANTY AFFIRMATION OF FACT, OF ANY KIND OR A WARRANTY OR AFFIRMATION OF FACT THAT THE PRODUCTS WILL CONFORM TO THEIR RESPECTIVE ILLUSTRATIONS OR DESCRIPTIONS. 4B EXPRESSLY DISCLAIMS ANY WARRANTY OR AFFIRMATION OF FACT, EXPRESSED OR IMPLIED, OTHER THAN AS SET FORTH IN THE EXCLUSIVE WRITTEN LIMITED WARRANTY STATEMENT ABOVE, INCLUDING, WITHOUT LIMITATION, THE IMPLIED WARRANTIES OF MERCHANTABILITY AND FITNESS FOR A PARTICULAR PURPOSE.

4. LIMITATION OF DAMAGES

ANY LIABILITY FOR CONSEQUENTIAL, INCIDENTAL, SPECIAL, EXEMPLARY, OR PUNITIVE DAMAGES, OR FOR LOSS OF PROFIT WHETHER DIRECT OR INDIRECT, IS EXPRESSLY DISCLAIMED.

With subsidiaries in North America, Europe, Asia, Africa and Australia along with a worldwide network of distributors, 4B can provide practical solutions for all your applications no matter the location.



4B BRAIME ELEVATOR COMPONENTS

Hunslet Road
Leeds LS10 1JZ
UK
Tel: +44 (0) 113 246 1800
Fax: +44 (0) 113 243 5021

4B DEUTSCHLAND

9 Route de Corbie
Lamotte Warfusee
F-8080
France
Tel: +49 (0) 700 2242 4091
Fax: +49 (0) 700 2242 3733

4B ASIA PACIFIC

68/19 Moo 5
Tambol Bangmuangmai
Amphur Muang Samutprakarn
10270
Thailand
Tel: +66 (0) 2 758-3648
Fax: +66 (0) 2 758-2926

4B COMPONENTS LTD.

625 Erie Ave.
Morton, IL 61550
USA
Tel: 309-698-5611
Fax: 309-698-5615

4B SETEM SARL

9 Route de Corbie
80800 Lamotte Warfusee
France
Tel: +33 (0) 3 22 42 32 26
Fax: +33 (0) 3 22 42 37 33

4B AFRICA

PO Box 1489
Jukskei Park
2153 Johannesburg
South Africa
Tel: +27 (0) 11 708 6114
Fax: +27 (0) 11 708 1654

4B AUSTRALIA

Unit 1-18
Overlord Place, Acacia Ridge
Queensland 4110
Australia
Tel: +61 (0) 7 3711 2565
Fax: +61 (0) 7 3711 2574

www.go4b.com