



Industrial Ethernet Switch

Industrial Ethernet Switch



EN - FR - CN - RU



INSTALLATION INSTRUCTIONS

OPERATION MANUAL

Part No. ETH-SWITCH1V4C-5P

www.go4b.com

! **DANGER**

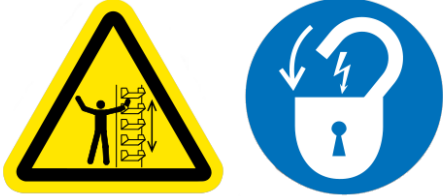

Exposed buckets and moving parts will cause severe injury or death.

Lockout power before removing cover or inspection door.

! **WARNING**



Moving parts can crush and cut.

Lockout power before removing guard or servicing.

Do NOT operate with guard removed

TABLE OF CONTENTS

1. CUSTOMER SAFETY RESPONSIBILITIES	Page 4 - 5
2. PRODUCT OVERVIEW	Page 6
3. SPECIFICATIONS	Page 6
4. DIMENSIONS	Page 6
5. INSTALLATION	Page 7
6. ELECTRICAL CONNECTION	Page 8
7. WIRING DIAGRAMS	Page 10
7.1 SUPPLY VOLTAGE WIRING (24 VDC)	Page 10
7.2 NETWORK BLOCK DIAGRAM	Page 10
8. IE-SWITCH OPERATION	Page 11
9. TROUBLESHOOTING GUIDE	Page 11
10. TESTING AND MAINTENANCE	Page 12
11. WARNINGS PRESENT ON PRODUCT	Page 12
12. PRODUCT WARRANTY	Page 15

1. CUSTOMER SAFETY RESPONSIBILITIES

4B appreciates your business and is pleased you have chosen our products to meet your needs.

Please read in its entirety and understand the literature accompanying the product before you place the product into service. Please read the safety precautions carefully before operating the product. With each product you purchase from 4B, there are some basic but important safety considerations you must follow to be sure your purchase is permitted to perform its design function and operate properly and safely, giving you many years of reliable service. Please read and understand the Customer Safety Responsibilities listed below. Failure to follow this safety directive and the Operation Manuals and other material furnished or referenced, may result in serious injury or death.

SAFETY NOTICE TO OUR CUSTOMERS

- A. In order to maximize efficiency and safety, selecting the right equipment for each operation is vital. The proper installation of the equipment, and regular maintenance and inspection is equally important in continuing the proper operation and safety of the product. The proper installation and maintenance of all our products is the responsibility of the user unless you have asked 4B to perform these tasks.
- B. All installation and wiring must be in accordance with Local and National Electrical Codes and other standards applicable to your industry. (Please see the article “Hazard Monitoring Equipment Selection, Installation and Maintenance” at www.go4b.com.) The installation of the wiring should be undertaken by an experienced and qualified professional electrician. Failure to correctly wire any product and/or machinery can result in the product or machine failing to operate as intended, and can defeat its design function.
- C. Periodic inspection by a qualified person will help assure your 4B product is performing properly. 4B recommends a documented inspection at least annually and more frequently under high use conditions.
- D. Please see the last page of this manual for all warranty information regarding this product.

CUSTOMER SAFETY RESPONSIBILITIES

1. READ ALL LITERATURE PROVIDED WITH YOUR PRODUCT

Please read all user, instruction and safety manuals to ensure that you understand your product operation and are able to safely and effectively use this product. If the equipment is used in a manner not specified in this manual, the protection provided by the equipment may be impaired.

2. YOU BEST UNDERSTAND YOUR NEEDS

Every customer and operation is unique, and only you best know the specific needs and capabilities of your operation. Please call the 24-hour hotline at 309-698-5611 for assistance with any questions about the performance of products purchased from 4B. 4B is happy to discuss product performance with you at any time.

3. SELECT A QUALIFIED AND COMPETENT INSTALLER

Correct installation of the product is important for safety and performance. If you have not asked 4B to perform the installation of the unit on your behalf, it is critical for the safety of your operation and those who may perform work on your operation that you select a qualified and competent electrical installer to undertake the installation. The product must be installed properly to perform its designed functions. The installer should be qualified, trained, and competent to perform the installation in accordance with Local and National Electrical Codes, all relevant OSHA Regulations, as well as any of your own standards and preventive maintenance requirements, and other product installation information supplied with the product. You should be prepared to provide the installer with all necessary installation information to assist in the installation.

4. ESTABLISH AND FOLLOW A REGULAR MAINTENANCE AND INSPECTION SCHEDULE FOR YOUR 4B PRODUCTS

You should develop a proper maintenance and inspection program to confirm that your system is in good working order at all times. You will be in the best position to determine the appropriate frequency for inspection. Many different factors known to the user will assist you in deciding the frequency of inspection. These factors may include but are not limited to weather conditions; construction work at the facility; hours of operation; animal or insect infestation; and the real-world experience of knowing how your employees perform their jobs. The personnel or person you select to install, operate, maintain, inspect or perform any work whatsoever, should be trained and qualified to perform these important functions. Complete and accurate records of the maintenance and inspection process should be created and retained by you at all times.

5. RETAIN AND REFER TO THE OPERATION MANUAL FOR 4B'S SUGGESTED MAINTENANCE AND INSPECTION RECOMMENDATIONS

As all operations are different, please understand that your specific operation may require additional adjustments in the maintenance and inspection process essential to permit the monitoring device to perform its intended function. Retain the Operation Manual and other important maintenance and service documents provided by 4B and have them readily available for people servicing your 4B equipment. Should you have any questions, please call the free 24-hour hotline number (309-698-5611).

6. SERVICE REQUEST

If you have questions or comments about the operation of your unit or require the unit to be serviced please contact the 4B location who supplied the product or send your request via fax (309-698-5615) or call us via our 24-hour hotline number in the USA (309-698-5611). Please have available product part numbers, serial numbers, and approximate date of installation. In order to assist you, after the product has been placed into service, complete the online product registration section which is accessed via our website www.go4b.com/usa.

WARNING

- Rotating machinery can cause serious injury or death
- Always lockout and tagout the machine prior to installation

2. PRODUCT OVERVIEW

The Industrial Ethernet Switch is an unmanaged switch with 5x RJ45 Ethernet sockets for 10/100 Mbps Ethernet Communications. It is designed to work with 4B's Industrial Ethernet Nodes (IE-NODEs) or any other devices requiring 10/100 Mbps Ethernet communications.

3. SPECIFICATIONS

Supply Voltage -	24 VDC
Power Dissipation -	12 Watts Maximum
Power Terminals -	14 AWG / 2.5 mm ²
Communication Protocols -	PROFINET, EtherNet/IP, Modbus TCP/IP or any other Ethernet protocol
Inputs	5x RJ-45 10/100 Mbps
Width -	7.4 in. (188 mm)
Depth -	4 in. (102 mm)
Height -	9.7 in. (246 mm)
Fixing Centers -	8.75 x 4 in. (222 x 102 mm)
Cable Entry -	2 Holes - 1-1/8 in. (28 mm) Diameter - 3/4 in. Conduit
Weight -	2.5 lbs / 1.1 kg
Protection -	IP66
Approvals -	<p>ATEX / IECEx/UKEX - V4 Ex tb IIIC T125° Db IP66 TAMB -20°C to +50°C IECEx BAS05.0026X CE 0598 UK CA 1180 Ex II 2D Ex tb IIIC T125° Db IP66 TAMB -20°C to +50°C Baseefa04ATEX0131X BAS21UKEX0306X</p> <p>ATEX / IECEx/UKEX - V46 Ex tc IIIC T125°Dc IP66 TAMB -20°C to +45°C IECEx BAS11.0018X CE 0598 UK CA 1180 Ex II 3D Ex tc IIIC T125°Dc IP66 TAMB -20°C to +45°C Baseefa II ATEX 0033X BAS21UKEX0309X</p> <p>CSA - V4 Ex tb IIIC T125°C Db IP66 Tamb -20°C to +50°C Zone 21 AEx tb IIIC T125°C Db IP66 Tamb -20°C to +50°C Class II Division 1, Groups E, F and G T125°C (When used with a Class2 power supply)</p> <p>CSA - V46 Ex tc IIIC T125°C Dc IP66 Tamb -20°C to +45°C Zone 22 AEx tc IIIC T125°C Dc IP66 Tamb -20°C to +45°C Class II Division 2, Groups F and G T125°C</p> <p>IP66</p>

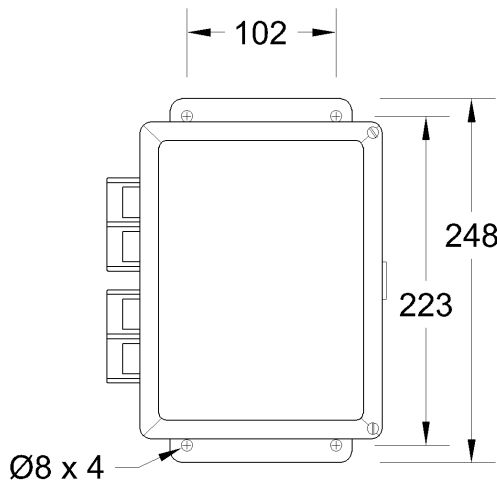

NOTE:

ALL DIMENSIONS IN MM

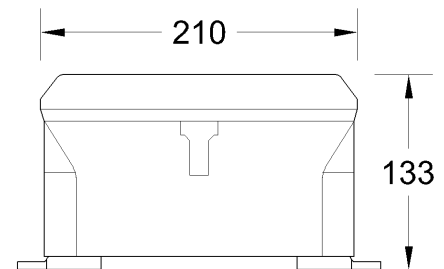
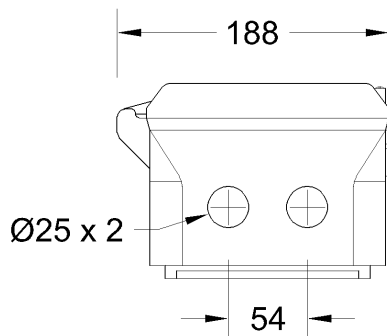

5. INSTALLATION

ENCLOSURE INSTALLATION -

1. Use the correct cable, glands and sealing arrangement in accordance to local installation codes.
2. Where other certified components are used as part of the assembly or installation procedure, the user must take in to account any limitations which might be listed on the relevant certificates.
3. The box is supplied with 2 x 1-1/8 inch (28 mm) pre drilled holes in the bottom face. All unused entry apertures must be sealed using component certified stopping plugs.

NOTE: Special Consideration when installed in a Class II environment: In order to connect conduit to the control unit enclosure, use a CSA and/or UL certified Class II conduit hub (for example, a Myers™ hub) with a suitable bonding (grounding) connection that is rated for the installation environment.

4. The enclosure must not be modified in any way, as this will invalidate the certification.
5. All wiring must be carried out in accordance with relevant codes of practice and / or instructions.

NOTE: Special Consideration when installed in a Class II environment: Power input and output (I/O) wiring shall be in accordance with Class II wiring methods per the National Electrical Code (NFPA70) for installations within the US and per the Canadian Electrical Code (CEC) for installations in Canada.

6. The voltage, current and maximum power dissipation on the units label must not be exceeded.
7. The wiring installation must extend to within 1 mm of the metal face of the terminal, and all leads must be insulated for the appropriate voltage.
8. Not more than one or multiple strand cable is to be connected to any terminal unless multiple conductors have previously been joined in a suitable manner (e.g. boot lace ferrule) such that they present a single connection point to the terminal.
9. The power terminals use a screwless push in spring design, a small flat-head or straight screwdriver can be used to gently push in the tab to terminate the power wires.
10. The equipment shall be earth bonded via earth bonded screw marked with the Earth label inside the equipment.

ENVIRONMENTAL CONDITIONS -

Unit can be used in outdoor locations, Ambient temperature and IP NEMA ratings should be considered. Product altitude is limited to 2000m above sea level. Humidity 0-100% RH, non-condensing.

WARNING

The Control Unit is susceptible to static voltage, static handling precautions should be taken. Connection of a clean ground to the Earth terminal is essential for optimum performance.

Static Hazard – Clean Only With A Damp Cloth

Remove Power Before Opening Cover – Do Not Apply Power When Cover Is Open.

6. ELECTRICAL CONNECTION

All wiring must be in accordance with local and national electrical codes and should be undertaken by an experienced and qualified electrician. All equipment should be properly grounded prior to operation.

Additional wire used during the installation must have a temperature rating of 158° F (70° C) or above, and be at least 24 AWG. 4B recommends using shielded cable to reduce electromagnetic interference (EMI) to maintain signal integrity. Never run low voltage cables in the same conduit as three phase motor cables.

Use rigid metal conduit to protect the cables coming into the Ethernet Switch. Conduit systems can channel water due to ingress and condensation which over time will adversely affect the performance of the system. As such, the installation of low point conduit drains is recommended.

All electrical connections are shown in image 1.

FUSE RATINGS -

In order to maintain the product certification, all fuses **MUST** be replaced with equivalent fuses at the same rating. Failure to do so will invalidate the certification and any warranties which may exist.

Model ETH-SWITCH1V4C-5P

- F5 200 mA.

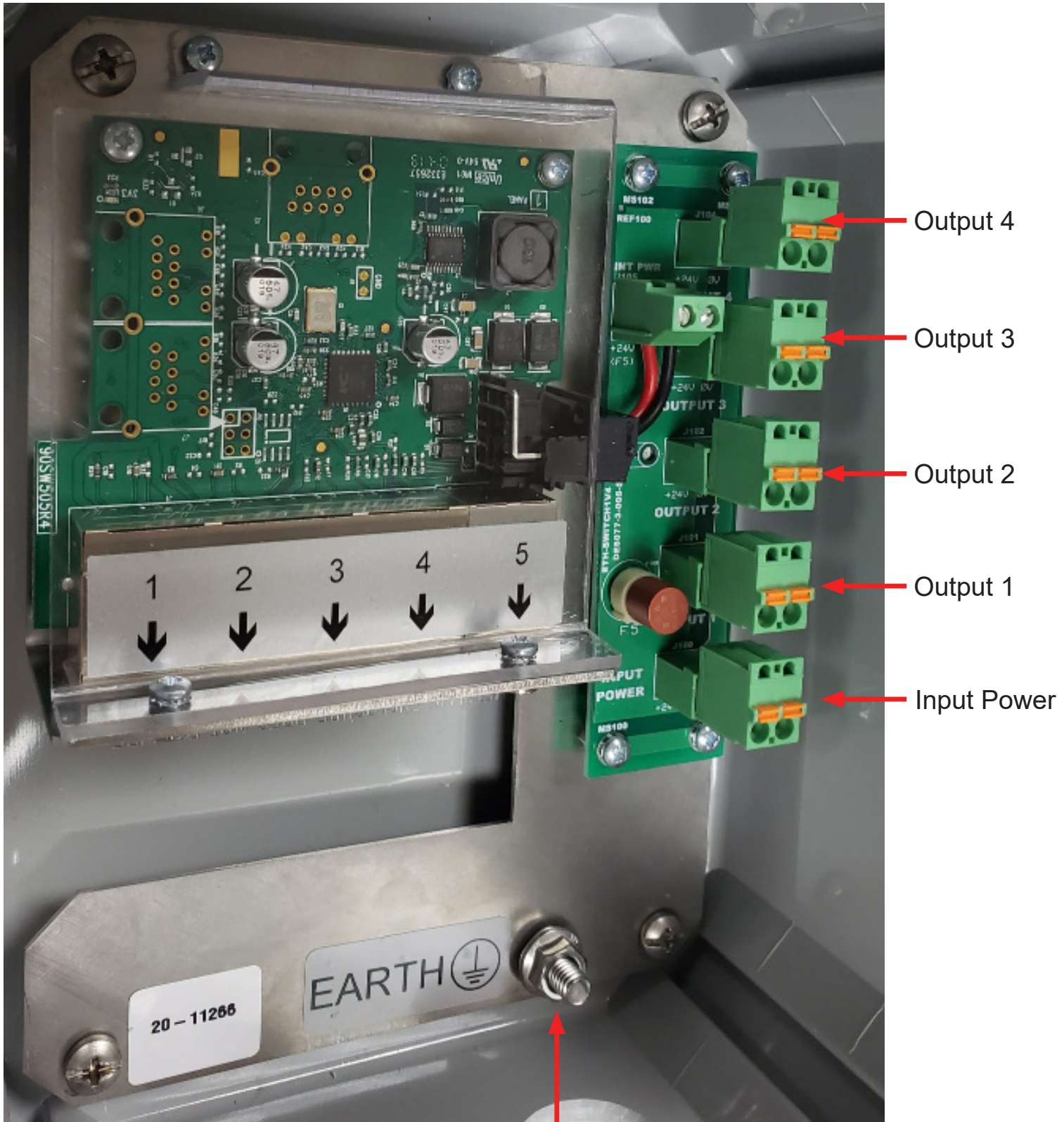
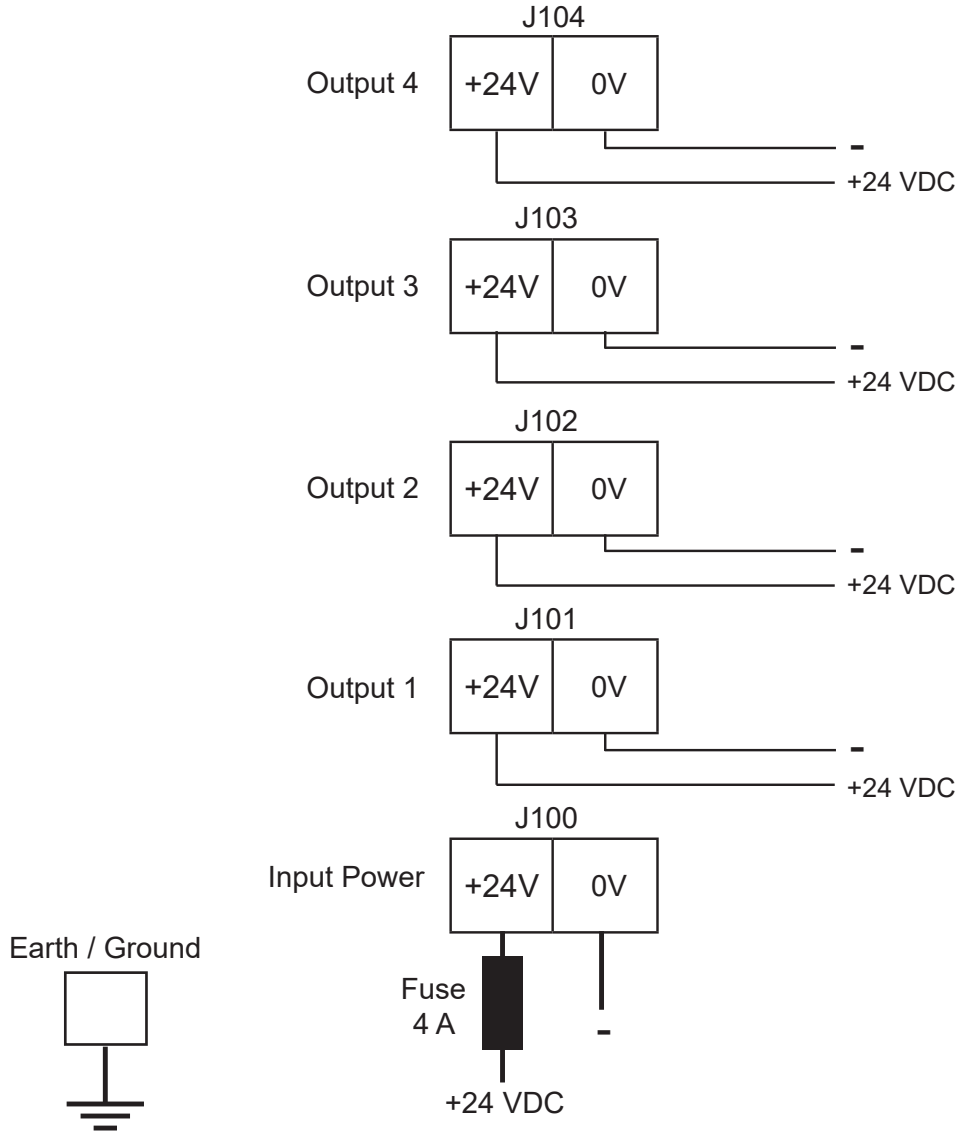

Image 1

Earth / Ground

7. WIRING DIAGRAMS

7.1 SUPPLY VOLTAGE WIRING (24 VDC)



7.2 NETWORK BLOCK DIAGRAM

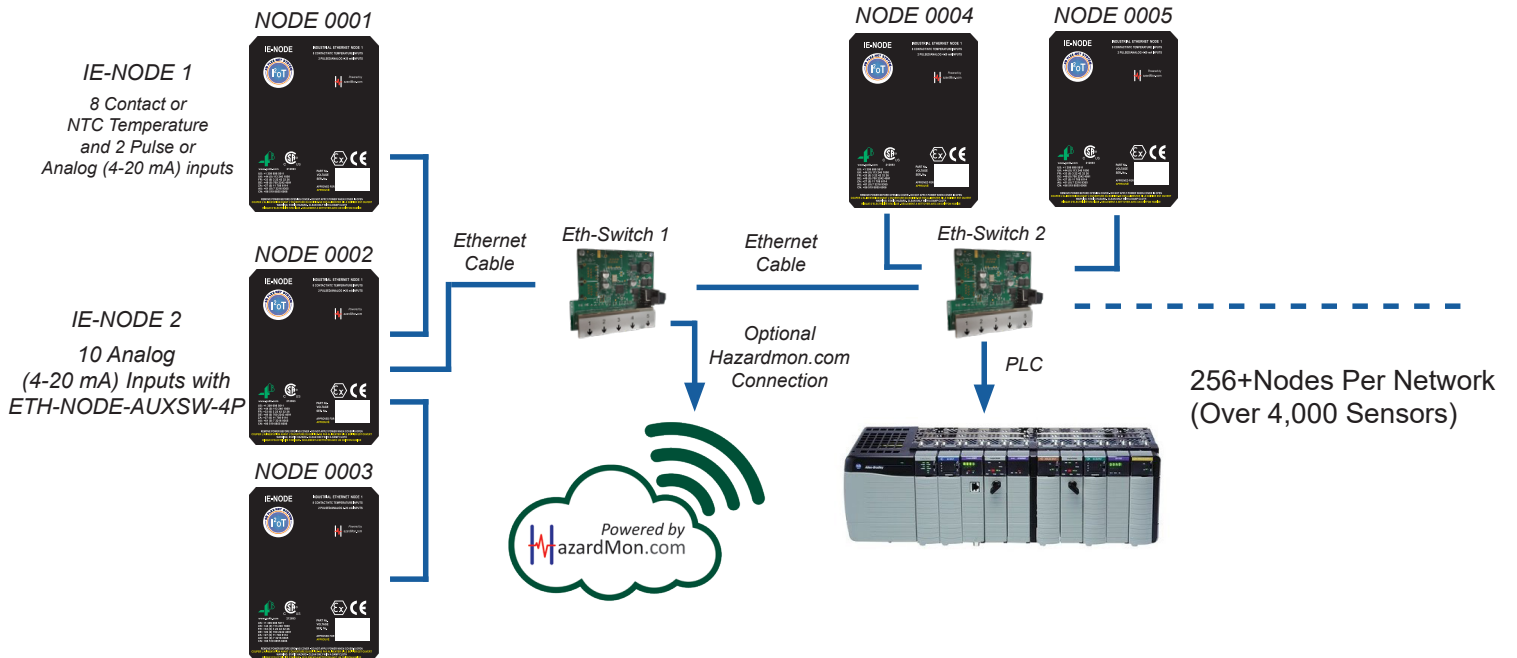

8. IE-SWITCH OPERATION

When the ETH-SWITCH has power, the POWER LED will illuminate red. Each Port on the switch has a green LED. When a cable is plugged into the port, the LED will illuminate solid green. When there is Ethernet activity on the port, the LED will flash green.

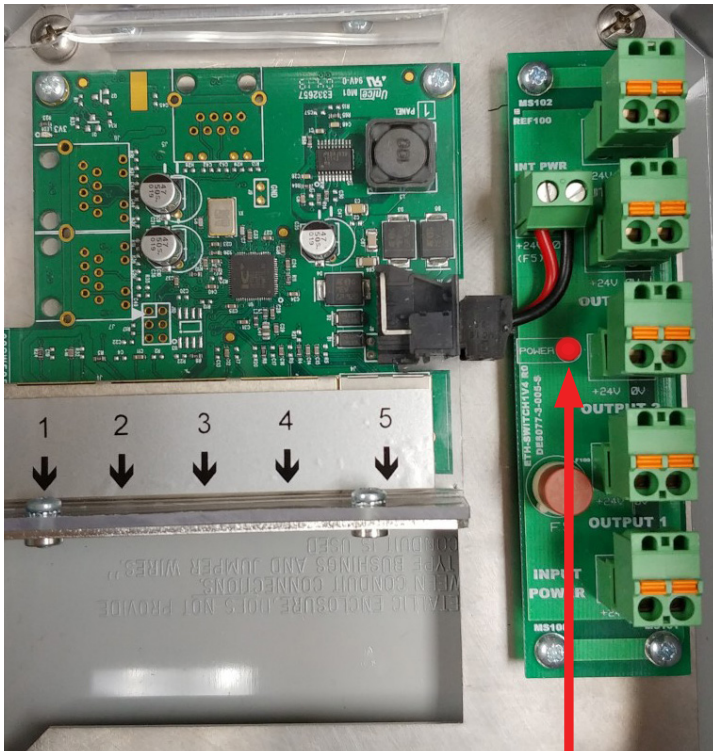

Red Power LED - On } Image 2

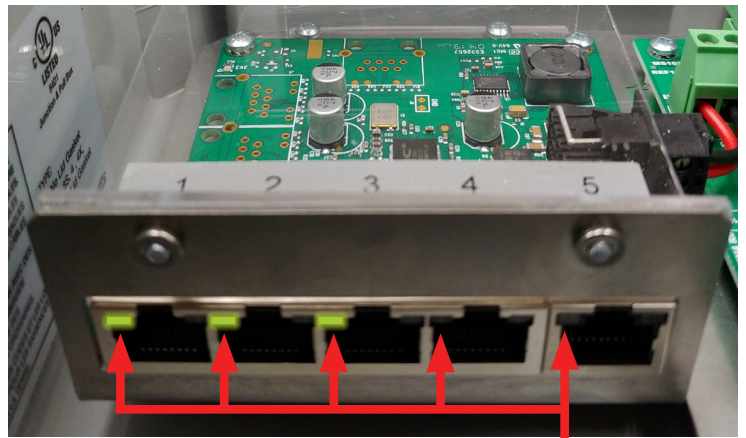

Image 3

Green Port LED On - Cable Is Plugged Into The Port
 Green Port LED Flashing - Ethernet Activity On The Port
 Port LED Off – Cable Unplugged From The Port

9. TROUBLESHOOTING GUIDE

CONDITION	SOLUTION
Power LED is Off	<ol style="list-style-type: none"> 1. Check that power is applied to the input terminal and polarity is correct. 2. Check that the fuse F5 is not damaged
Network Communications is not working	<ol style="list-style-type: none"> 1. Check that the Power LED is on 2. Check that the activity LED is on / flashing 3. Check IP configuration of devices
Activity LED is off	<ol style="list-style-type: none"> 1. Check that the Power LED is on 2. Check that the RJ-45 connector is fully seated in the socket 3. Check that the CAT5/CAT6 cable is following the T568A or T568B standard

10. TESTING AND MAINTENANCE

Below is the procedure that the end user must adhere to in order to maintain the system in a safe state.

1. Inspect that all the cabling is in good state and that all the electrical connections, including the terminal blocks in the junction boxes are secure and in good order.
2. Make sure there is no water damage to the inside of the enclosure or any junction boxes used.
3. Verify that the LED marked POWER is illuminated red.

WARNING

If the system does not immediately shutdown as expected or alarm as required, then remove the machine from service until the problem has been diagnosed and corrected.

11. WARNINGS PRESENT ON PRODUCT

WARNING – EXPLOSION HAZARD – Do not connect or disconnect while circuit is live unless area is known to be non-hazardous

AVERTISSEMENT - RISQUE D'EXPLOSION – Ne pas debrancher tant que le circuit est sous tension, a moins qu'il ne s'agisse d'un emplacement non dangereux

POTENTIAL ELECTROSTATIC CHARGING HAZARD –CLEAN ONLY WITH A DAMP CLOTH
RISQUE DE CHARGE ÉLECTROSTATIQUE POTENTIEL - NETTOYAGE AVEC UN CHIFFON HUMIDE SEULEMENT

DO NOT OPEN WHEN ENERGIZED
NE PAS OUVRIR LORSQU'IL EST ÉNERGISÉ

Manufactured by Don Electronics Limited, Westfield Industrial Estate, Kirk Lane, Yeadon, Leeds, LS19 7LX, United Kingdom

12. PRODUCT WARRANTY

1. EXCLUSIVE WRITTEN LIMITED WARRANTY

ALL PRODUCTS SOLD ARE WARRANTED BY THE COMPANY 4B COMPONENTS LIMITED AND 4B BRAIME COMPONENTS LIMITED HEREIN AFTER REFERRED TO AS 4B TO THE ORIGINAL PURCHASER AGAINST DEFECTS IN WORKMANSHIP OR MATERIALS UNDER NORMAL USE FOR ONE (1) YEAR AFTER DATE OF PURCHASE FROM 4B. ANY PRODUCT DETERMINED BY 4B AT ITS SOLE DISCRETION TO BE DEFECTIVE IN MATERIAL OR WORKMANSHIP AND RETURNED TO A 4B BRANCH OR AUTHORIZED SERVICE LOCATION, AS 4B DESIGNATES, SHIPPING COSTS PREPAID, WILL BE, AS THE EXCLUSIVE REMEDY, REPAIRED OR REPLACED AT 4B'S OPTION.

2. DISCLAIMER OF IMPLIED WARRANTY

NO WARRANTY OR AFFIRMATION OF FACT, EXPRESSED OR IMPLIED, OTHER THAN AS SET FORTH IN THE EXCLUSIVE WRITTEN LIMITED WARRANTY STATEMENT ABOVE IS MADE OR AUTHORIZED BY 4B. 4B SPECIFICALLY DISCLAIMS ANY LIABILITY FOR PRODUCT DEFECT CLAIMS THAT ARE DUE TO PRODUCT MISUSE, ABUSE OR MISAPPLICATIONS, AS AUTHORIZED BY LAW, 4B SPECIFICALLY DISCLAIMS ALL WARRANTIES THAT THE PRODUCT IS FIT OR MERCHANTABLE FOR A PARTICULAR PURPOSE.

3. NO WARRANTY "BY SAMPLE OR EXAMPLE"

ALTHOUGH 4B HAS USED REASONABLE EFFORTS TO ACCURATELY ILLUSTRATE AND DESCRIBE THE PRODUCTS IN ITS CATALOGS, LITERATURE, AND WEBSITES, SUCH ILLUSTRATIONS AND DESCRIPTIONS ARE FOR THE SOLE PURPOSE OF PRODUCT IDENTIFICATION AND DO NOT EXPRESS OR IMPLY A WARRANTY AFFIRMATION OF FACT, OF ANY KIND OR A WARRANTY OR AFFIRMATION OF FACT THAT THE PRODUCTS WILL CONFORM TO THEIR RESPECTIVE ILLUSTRATIONS OR DESCRIPTIONS. 4B EXPRESSLY DISCLAIMS ANY WARRANTY OR AFFIRMATION OF FACT, EXPRESSED OR IMPLIED, OTHER THAN AS SET FORTH IN THE EXCLUSIVE WRITTEN LIMITED WARRANTY STATEMENT ABOVE, INCLUDING, WITHOUT LIMITATION, THE IMPLIED WARRANTIES OF MERCHANTABILITY AND FITNESS FOR A PARTICULAR PURPOSE.

4. LIMITATION OF DAMAGES

ANY LIABILITY FOR CONSEQUENTIAL, INCIDENTAL, SPECIAL, EXEMPLARY, OR PUNITIVE DAMAGES, OR FOR LOSS OF PROFIT WHETHER DIRECT OR INDIRECT, IS EXPRESSLY DISCLAIMED.

With subsidiaries in North America, Europe, China, Asia, Africa and Australia along with a worldwide network of distributors, 4B can provide practical solutions for all your applications no matter the location.



4B BRAIME COMPONENTS LTD.

Hunslet Road
Leeds
LS10 1JZ
United Kingdom
Tel: +44 (0) 113 246 1800
Email: 4b-uk@go4b.com

4B DEUTSCHLAND

35 Bis Rue Du 8 Mai 1945
80800 Villers, Bretonneux
France
Tel: +49 (0) 2333 601681
Email: 4b-deutschland@go4b.com

4B AFRICA

14 Newport Business Park
Mica Drive, Kya Sand
2163 Johannesburg
South Africa
Tel: +27 (0) 11 708 6114
Email: 4b-africa@go4b.com

4B FRANCE

35 Bis Rue Du 8 Mai 1945
80800 Villers, Bretonneux
France
Tel: +33 (0) 3 22 42 32 26
Email: 4b-france@go4b.com

4B COMPONENTS LTD.

625 Erie Avenue
Morton, IL 61550
USA
Tel: 309-698-5611
Fax: 309-698-5615

4B ASIA PACIFIC

Build No. 899/1 Moo 20
Soi Chongsiri, Bangplee-Tam
Ru Road, Tanbon Bangpleeyai,
Amphur Bangplee,
Samutprakarn 10540
Thailand
Tel: +66 (0) 2 173-4339
Email: 4b-asiapacific@go4b.com

4B China

F1, Building 5A,
Jintong Industrial Park,
8 West Lake Road,
Wujin High & New TDZ,
Changzhou, Jiangsu, PRC
Tel: +86-519-88556006
Email: 4b-china@go4b.com

4B AUSTRALIA

Building 1, 41 Bellrick Street
Acacia Ridge
Queensland 4110
Australia
Tel: +61 (0)7 3216 9365
Email: 4b-australia@go4b.com



www.go4b.com