

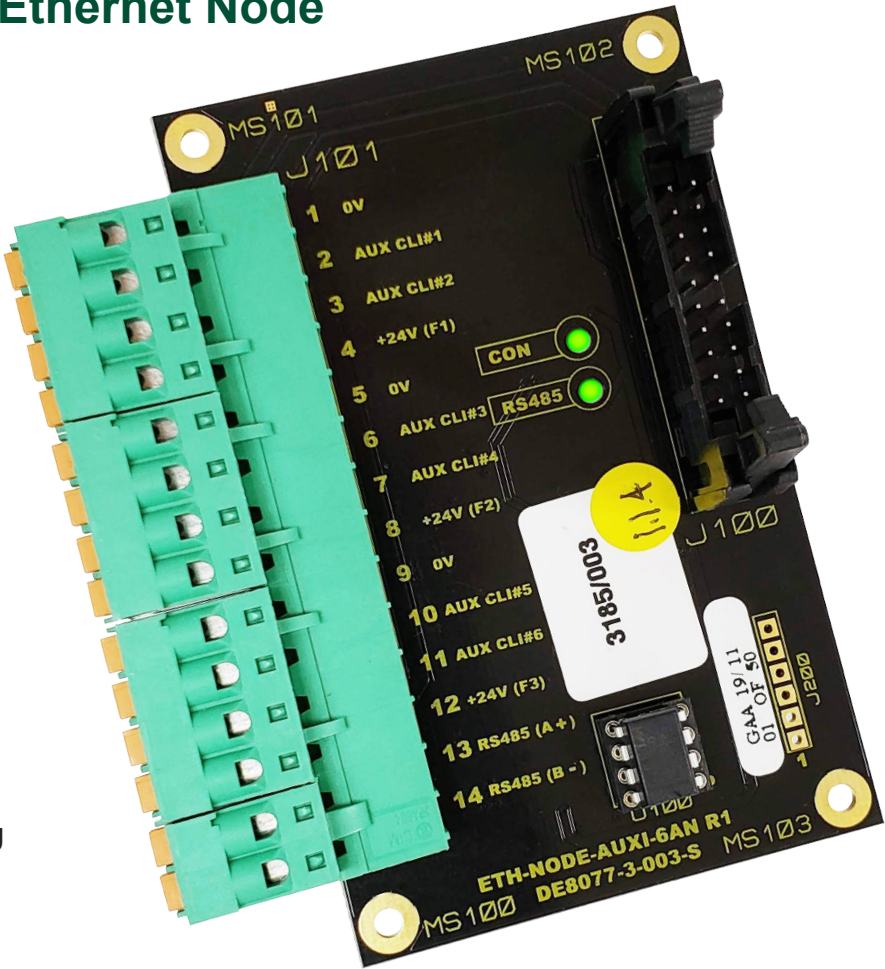

# 4-20 mA Expansion Board CURRENT LOOP SENSORS

**IE-NODE**  
Industrial Ethernet Node



EN - FR - CN - RU



**INSTALLATION INSTRUCTIONS**

# OPERATION MANUAL

Part No. ETH-NODE-AUXI-6AN

[www.go4b.com](http://www.go4b.com)



# TABLE OF CONTENTS

CUSTOMER SAFETY RESPONSIBILITIES	Page 4 - 5
PRODUCT OVERVIEW	Page 6
SPECIFICATIONS	Page 6
INSTALLATION	Page 7 - 8
ELECTRICAL CONNECTION	Page 9 - 12
OPERATION	Page 13
TROUBLESHOOTING GUIDE	Page 13
PRODUCT WARRANTY	Page 15

# CUSTOMER SAFETY RESPONSIBILITIES

4B appreciates your business and is pleased you have chosen our products to meet your needs.

Please read in its entirety and understand the literature accompanying the product before you place the product into service. Please read the safety precautions carefully before operating the product. With each product you purchase from 4B, there are some basic but important safety considerations you must follow to be sure your purchase is permitted to perform its design function and operate properly and safely, giving you many years of reliable service. Please read and understand the Customer Safety Responsibilities listed below. Failure to follow this safety directive and the Operation Manuals and other material furnished or referenced, may result in serious injury or death.

## ***SAFETY NOTICE TO OUR CUSTOMERS***

- A. In order to maximize efficiency and safety, selecting the right equipment for each operation is vital. The proper installation of the equipment, and regular maintenance and inspection is equally important in continuing the proper operation and safety of the product. The proper installation and maintenance of all our products is the responsibility of the user unless you have asked 4B to perform these tasks.
- B. All installation and wiring must be in accordance with Local and National Electrical Codes and other standards applicable to your industry. (Please see the article “Hazard Monitoring Equipment Selection, Installation and Maintenance” at [www.go4b.com](http://www.go4b.com).) The installation of the wiring should be undertaken by an experienced and qualified professional electrician. Failure to correctly wire any product and/or machinery can result in the product or machine failing to operate as intended, and can defeat its design function.
- C. Periodic inspection by a qualified person will help assure your 4B product is performing properly. 4B recommends a documented inspection at least annually and more frequently under high use conditions.
- D. Please see the last page of this manual for all warranty information regarding this product.

## ***CUSTOMER SAFETY RESPONSIBILITIES***

### **1. READ ALL LITERATURE PROVIDED WITH YOUR PRODUCT**

Please read all user, instruction and safety manuals to ensure that you understand your product operation and are able to safely and effectively use this product. If the equipment is used in a manner not specified in this manual, the protection provided by the equipment may be impaired.

### **2. YOU BEST UNDERSTAND YOUR NEEDS**

Every customer and operation is unique, and only you best know the specific needs and capabilities of your operation. Please call the 24-hour hotline at 309-698-5611 for assistance with any questions about the performance of products purchased from 4B. 4B is happy to discuss product performance with you at any time.

### **3. SELECT A QUALIFIED AND COMPETENT INSTALLER**

Correct installation of the product is important for safety and performance. If you have not asked 4B to perform the installation of the unit on your behalf, it is critical for the safety of your operation and those who may perform work on your operation that you select a qualified and competent electrical installer to undertake the installation. The product must be installed properly to perform its designed functions. The installer should be qualified, trained, and competent to perform the installation in accordance with Local and National Electrical Codes, all relevant OSHA Regulations, as well as any of your own standards and preventive maintenance requirements, and other product installation information supplied with the product. You should be prepared to provide the installer with all necessary installation information to assist in the installation.

### **4. ESTABLISH AND FOLLOW A REGULAR MAINTENANCE AND INSPECTION SCHEDULE FOR YOUR 4B PRODUCTS**

You should develop a proper maintenance and inspection program to confirm that your system is in good working order at all times. You will be in the best position to determine the appropriate frequency for inspection. Many different factors known to the user will assist you in deciding the frequency of inspection. These factors may include but are not limited to weather conditions; construction work at the facility; hours of operation; animal or insect infestation; and the real-world experience of knowing how your employees perform their jobs. The personnel or person you select to install, operate, maintain, inspect or perform any work whatsoever, should be trained and qualified to perform these important functions. Complete and accurate records of the maintenance and inspection process should be created and retained by you at all times.

### **5. RETAIN AND REFER TO THE OPERATION MANUAL FOR 4B'S SUGGESTED MAINTENANCE AND INSPECTION RECOMMENDATIONS**

As all operations are different, please understand that your specific operation may require additional adjustments in the maintenance and inspection process essential to permit the monitoring device to perform its intended function. Retain the Operation Manual and other important maintenance and service documents provided by 4B and have them readily available for people servicing your 4B equipment. Should you have any questions, please call the free 24-hour hotline number (309-698-5611).

### **6. SERVICE REQUEST**

If you have questions or comments about the operation of your unit or require the unit to be serviced please contact the 4B location who supplied the product or call us via our 24-hour hotline number in the USA (309-698-5611). Please have available product part numbers, serial numbers, and approximate date of installation. In order to assist you, after the product has been placed into service, complete the online product registration section which is accessed via our website [www.go4b.com](http://www.go4b.com).

## ! WARNING

- Rotating machinery can cause serious injury or death
- Always lockout and tagout the machine prior to installation

## PRODUCT OVERVIEW

The 4-20 mA expansion board provides the ability to connect 6 additional 4-20 mA (current loop) sensors to the IE-Node. The board also adds the capability to allow for a half duplex RS485 Modbus RTU connection to be made to the device to access all onboard sensor information.

## SPECIFICATIONS

Inputs -	<ul style="list-style-type: none"><li>• 4-20 mA (Current Loop)</li><li>• 3 Sensor Power Supply (24 VDC)</li><li>• 1 Half Duplex Modbus RTU Communications</li></ul>
Contact Input Range -	0 to 24 VDC
Dimensions -	95 mm x 77 mm x 30 mm ( L x W x H)
Approvals - (When Installed in IE-Node)	<ul style="list-style-type: none"><li>• CSA (Master Contract Ref: 212693)</li><li>• CSA Class II Div 1 Groups E, F &amp; G (ETH-NODE1V4C and ETH-NODE2V4C)</li><li>• ATEX &amp; CE (Versions Available)</li><li>• For all approval requirements please refer to the ETH-NODE manual.</li></ul>

## EXPANSION BOARD KIT CONTENTS

1. 4-20 mA Board (1)
2. Extra Large Hex Pillar (1)
3. Large Hex Pillar A (1)
4. Large Hex Pillar B (1)
5. Small Hex Pillars (3)
6. Mounting Plate (1)

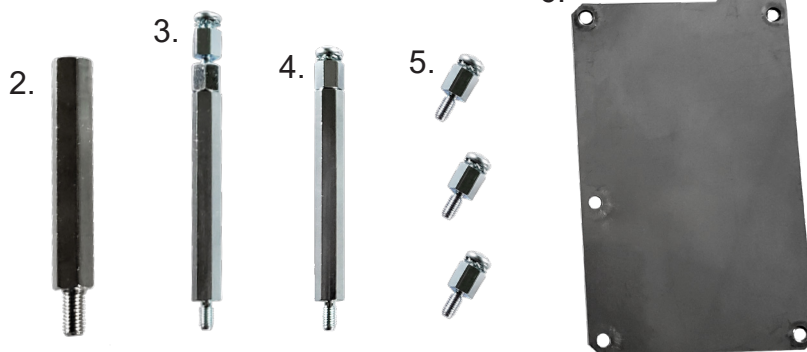
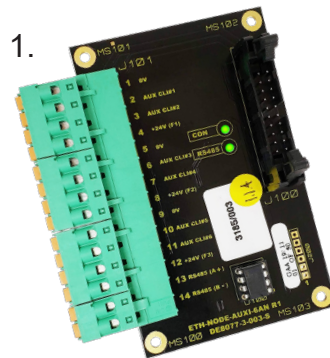

## ! WARNING

Expansion board is NOT suitable for HOT INSTALL. Never install expansion board while the IE-Node is powered or damage will occur. Always remove power from the IE-Node prior to board installation.

## INSTALLATION

For factory pre-installed boards, skip to *Electrical Connection* on page 9.

Step 1 - Remove power from the IE-Node before proceeding with the expansion board installation.

Step 2 (Image A) - Remove the large Phillips screw on the top right corner of the control units board and be sure to keep it for step 4. Note the two locations for hex pillar installation.

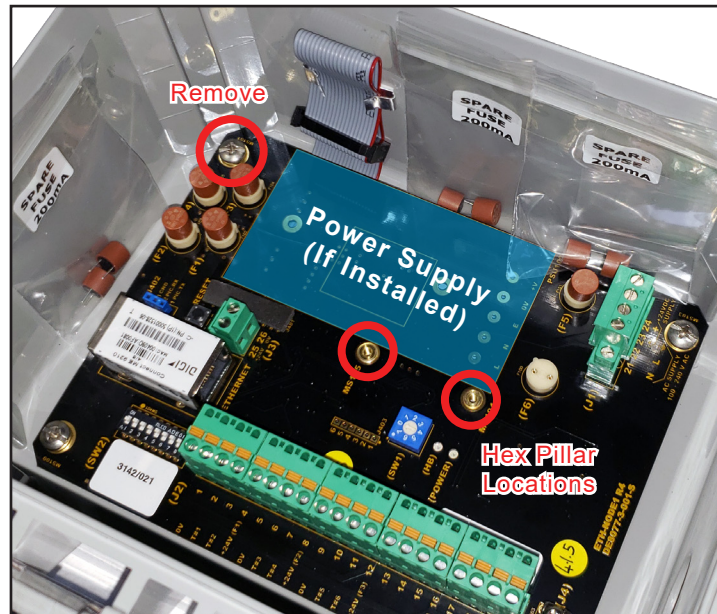

Image A

Step 3 (Image B) - Install the extra large hex pillar into the location from where the Phillips screw was removed. Install two of the large hex pillars into the open locations on the control units board. Note that there should be a small hex pillar installed on top of both large hex pillars.

Loosen the ribbon cable retention clip and place the cable end out of the way of the installation. The cable will be attached to the expansion board after installation has been completed.

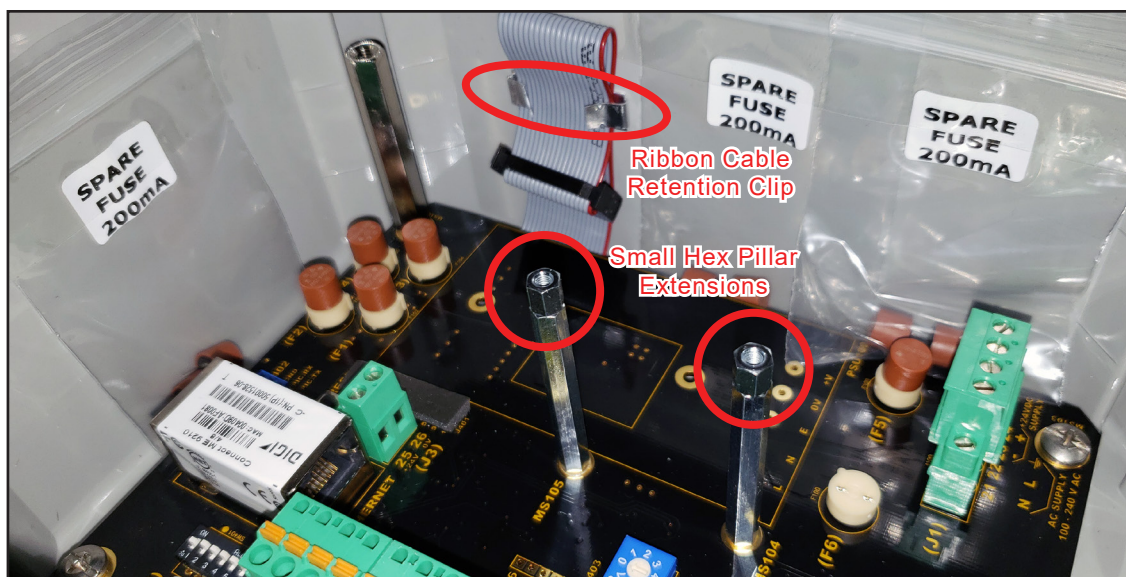
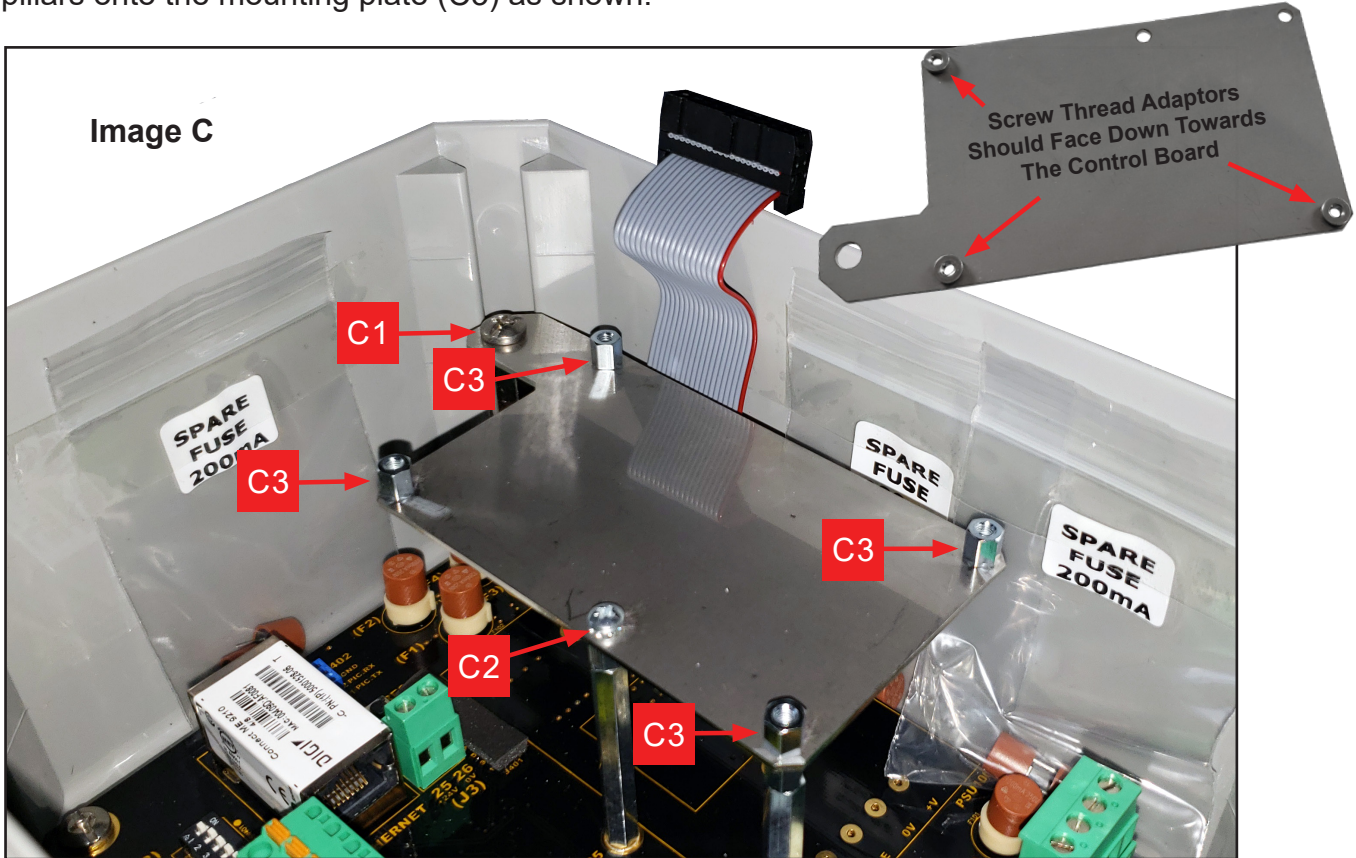

Image B

Step 4 (Image C) - Install mounting plate as shown. The smooth side of the mounting plate will face up, the screw thread adaptor side should be facing towards the control board.

The control board screw removed from step 2 will be used to secure the extra large hex pillar (C1). Use one of the included small screws to attach the middle large hex pillar (C2). Finally, install the four small hex pillars onto the mounting plate (C3) as shown.



Step 5 (Image D) - Using the remaining four small screws, attach the 4-20 mA expansion board to the mounting plate (D1 - D4) using the four small hex pillars from step 4.

Install the ribbon cable to the expansion board and make sure the cable locking clamps are engaged and the cable is secured to the expansion board.

Installation of the 4-20 mA expansion board is now complete. Proceed to the ELECTRICAL CONNECTION section for sensor wiring information.

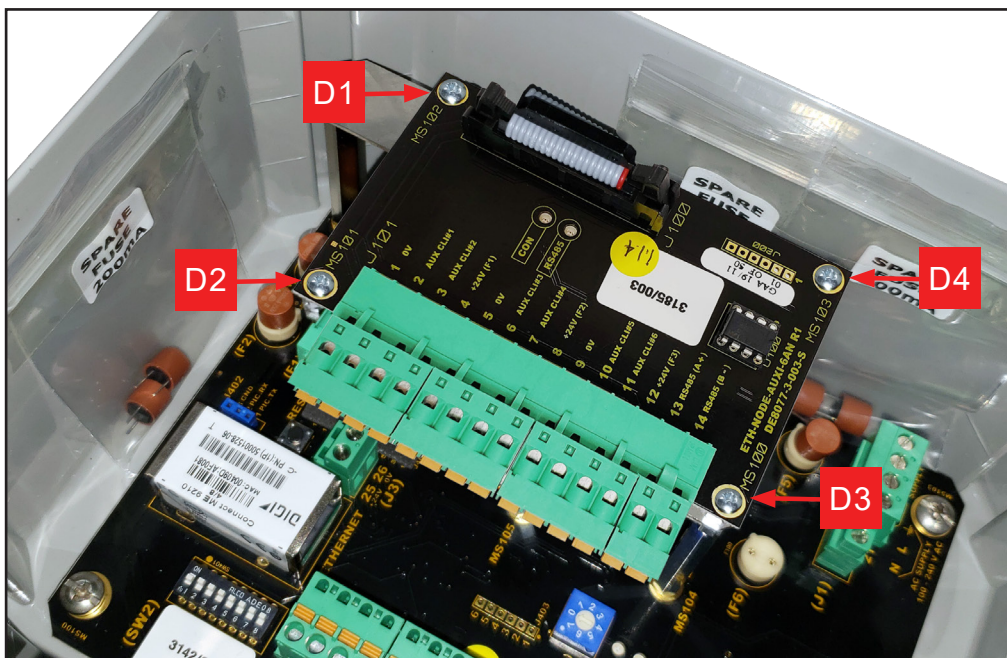

Image D



# ELECTRICAL CONNECTION

All wiring must be in accordance with local and national electrical codes and should be undertaken by an experienced and qualified electrician.

Always use dust/liquid tight flexible metal conduit with approved fittings to protect the sensor cables. Use rigid metal conduit to protect the cables from the sensors to the control unit. Conduit systems can channel water due to ingress and condensation directly to sensors and sensor connections which over time will adversely affect the performance of the system. As such, the installation of low point conduit drains is recommended for all sensors.

For more information regarding IE-Node wiring, refer to the IE-Node manual, or contact 4B.

## WARNING

Expansion board is NOT suitable for HOT INSTALL. Never install expansion board while the IE-Node is powered or damage will occur. Always remove power from the IE-Node prior to board installation.

The 4-20 mA expansion board has the following connections available -

Terminal	Description
1	Ground (0V)
2	4-20 mA Current Loop Input #1
3	4-20 mA Current Loop Input #2
4	+24 VDC (F1)
5	Ground (0V)
6	4-20 mA Current Loop Input #3
7	4-20 mA Current Loop Input #4
8	+24 VDC (F2)
9	Ground (0V)
10	4-20 mA Current Loop Input #5
11	4-20 mA Current Loop Input #6
12	+24 VDC (F3)
13	RS485 (A+)
14	RS485 (B-)

## NOTE

Recommended cable type is Belden 5508FE with 10 conductors each 22 AWG, shielded. Overall outer diameter is 0.23 inches.

# MILLI-TEMP TEMPERATURE SENSOR WIRING -

4-20 mA temperature sensors are non-polarity sensitive, however 4B recommends wiring the sensors as outlined below.

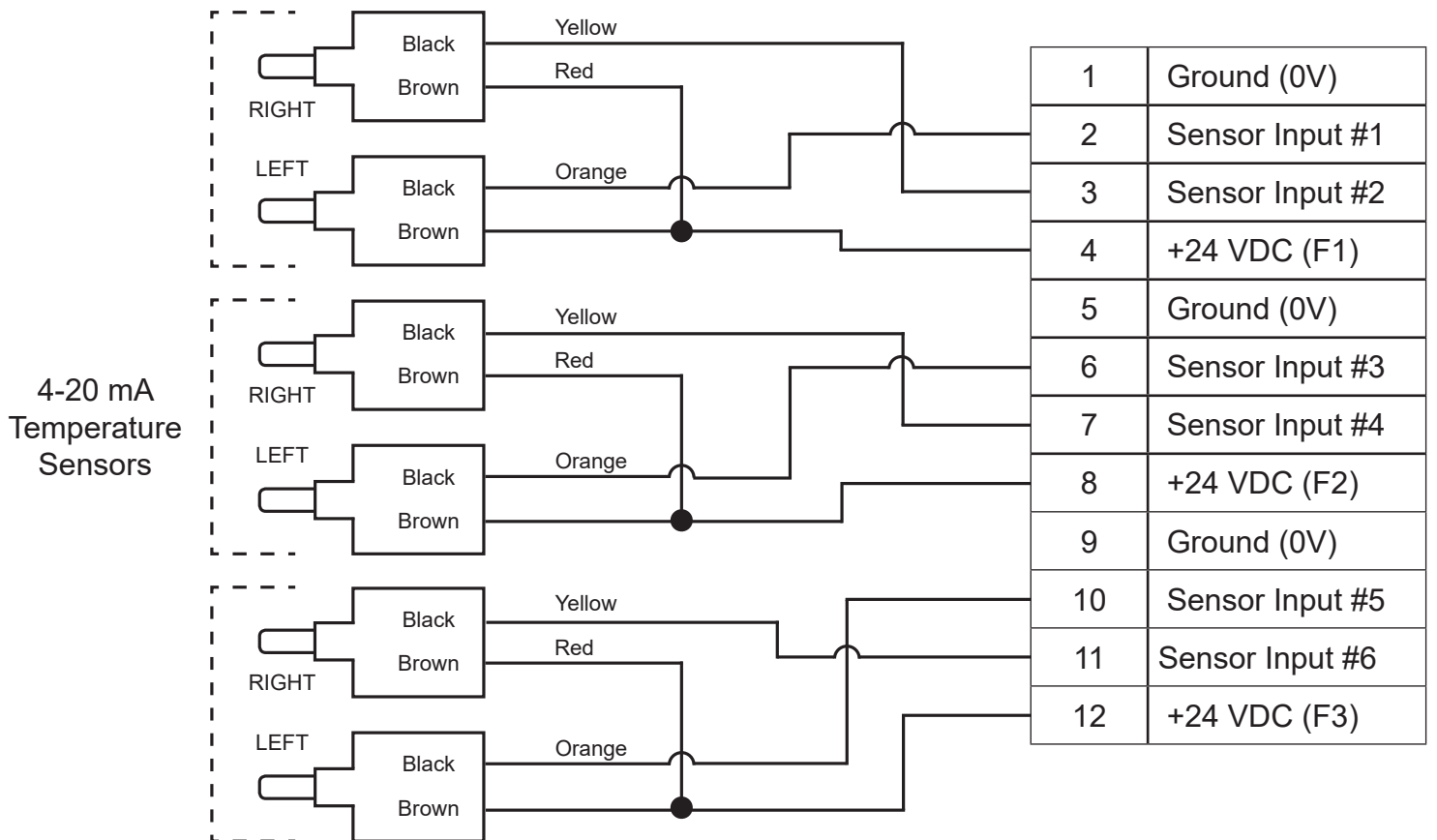
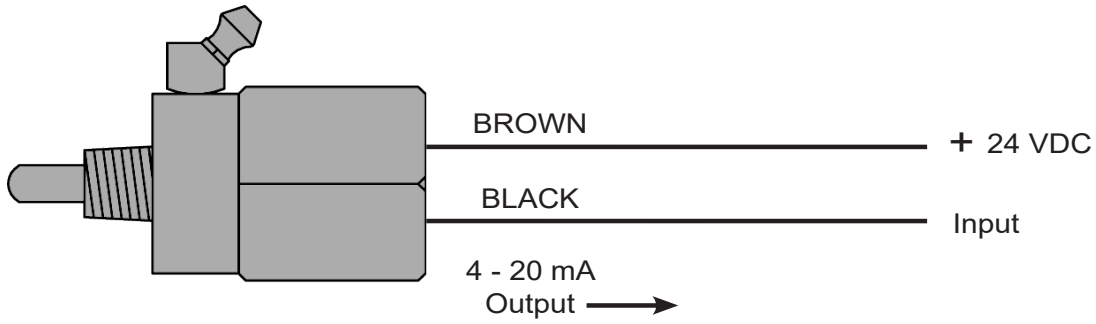

# MILLI-SPEED SENSOR WIRING -

Supply polarity to the Milli-Speed is not important and the load can be connected to either wire.

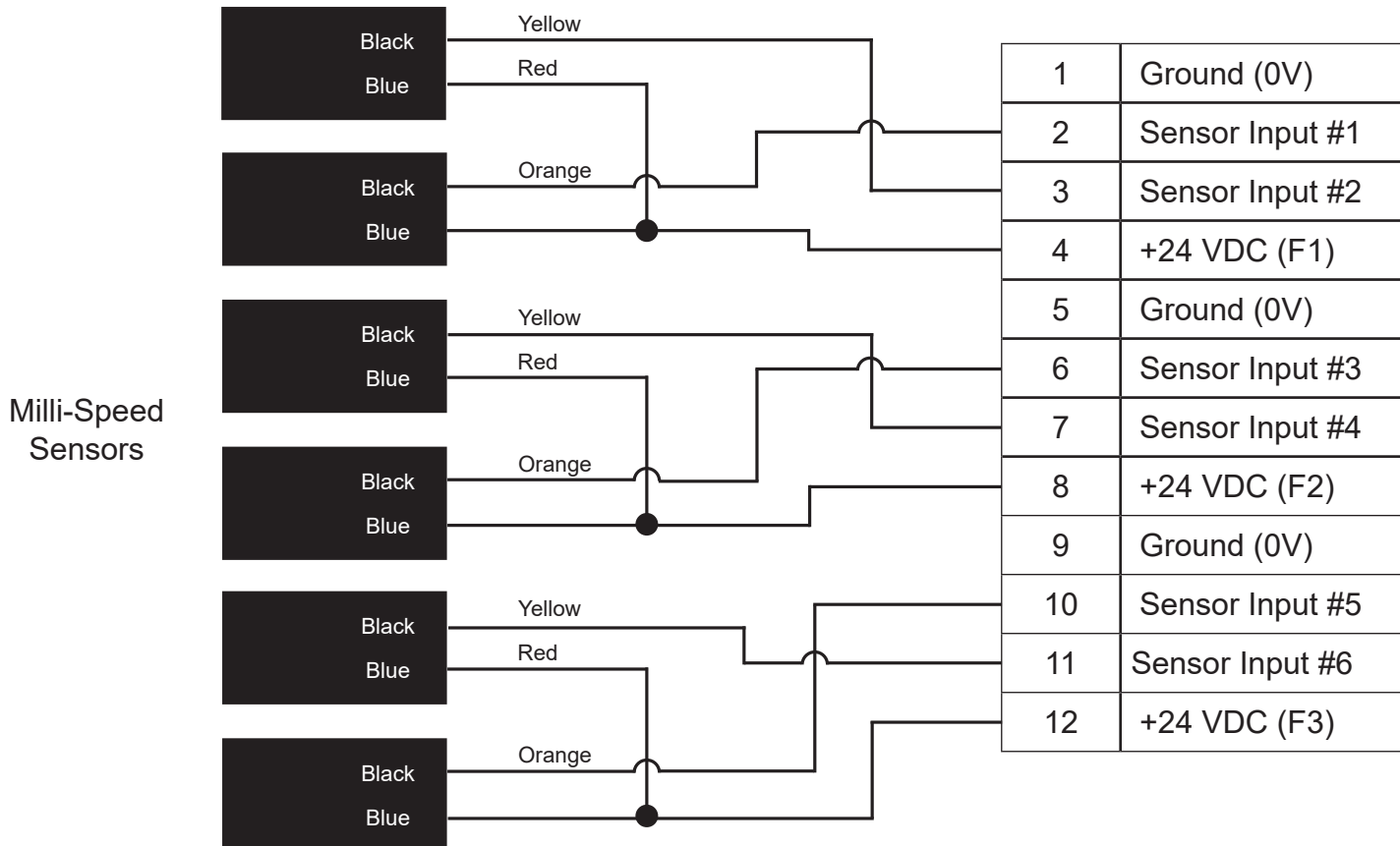
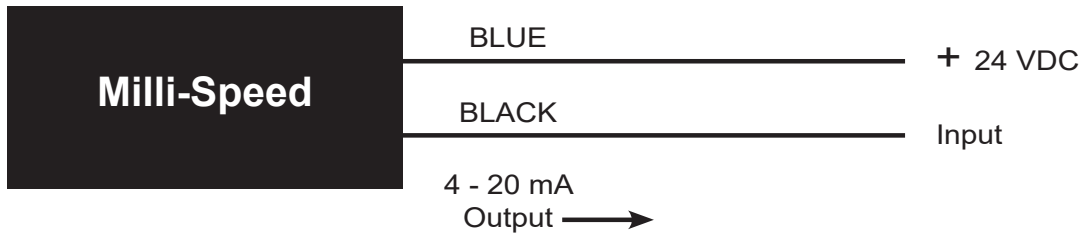

## RS485 MODBUS RTU -

The RS485 connection uses a half duplex connection, see table below for details. For information on configuring Modbus RTU addresses, see the IE-Node manual.

Property	Value
Baud Rate	115200
Data Bits	8
Parity	None
Stop Bits	1

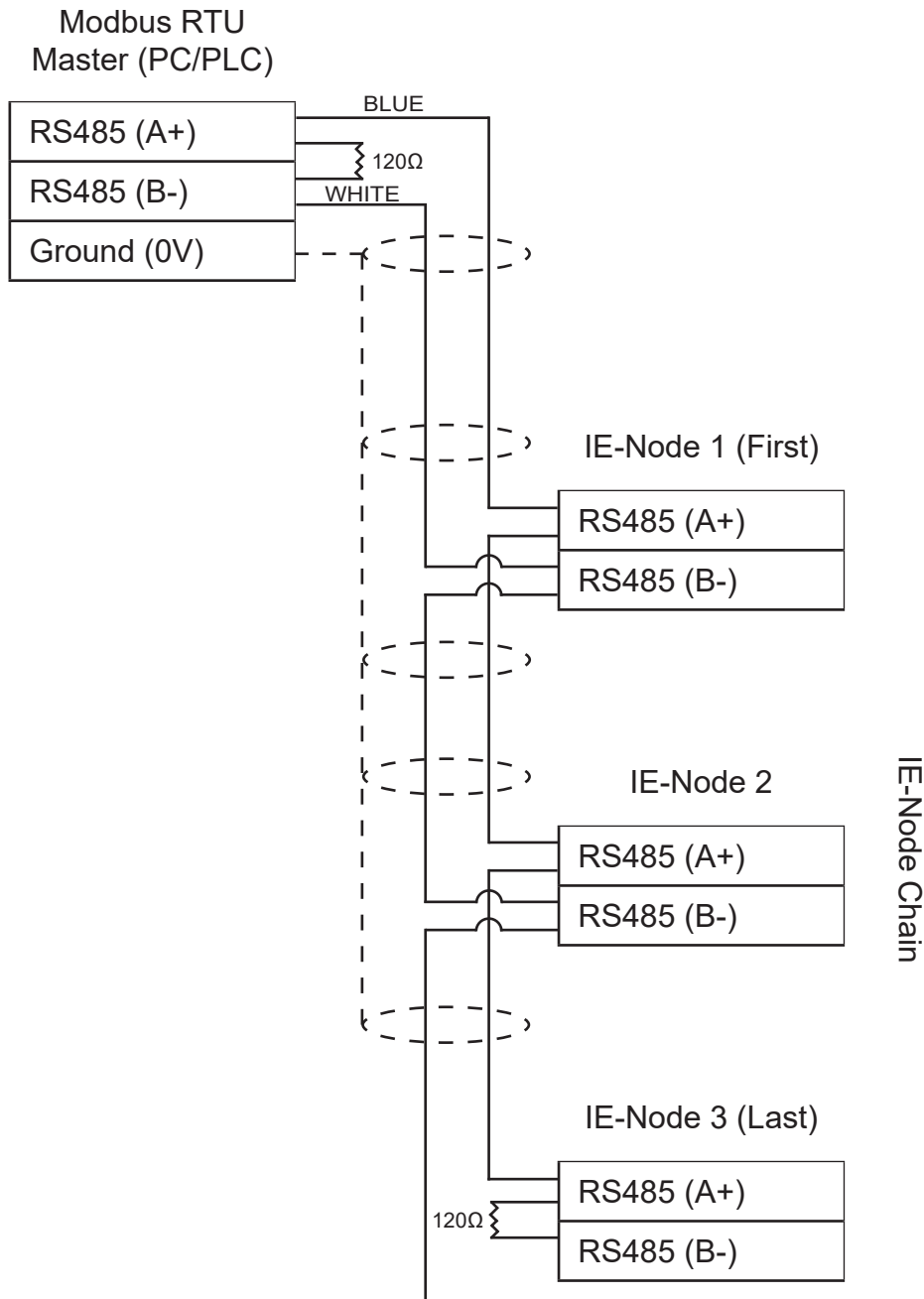

## NOTE

Recommended cable type is Belden 9841 or Equivalent.

# OPERATION

At startup, the CON LED should flash several times and may pause briefly before communication is established with the main Ethernet Node Board. When communication is established, the CON LED should then continue flashing at a consistent rate. If the LED is not flashing, the connection with the main board has been lost.

LED Behavior	CON	RS485
Off	No Connection with Main Board	No Modbus Comms
Flashing	Normal Operation	Modbus Comms Active
Fading	Bootloader Mode	Bootloader Mode

Each flash of the RS485 LED indicates a successful receipt of a single Modbus RTU message. It should be off if there is no activity via the RS485 port.

In order to utilise the Modbus RTU connection, the Node ID for the device has to be configured. This can be done in one of two ways, via the rotary switch on the main board or via an internal register that can be set via command.

### NODE ID VIA ROTARY SWITCH -

Ensure that the main IE-Node board dipswitch 8 (RTU Node ID Source) is set to the LEFT position (OFF). The rotary switch will then select the Node ID.

Note that 0 is not a permissible address for a Modbus RTU slave. If the rotary switch is set to 0, the node ID will be set to 100 by default.

### NODE ID VIA INTERNAL REGISTER -

Ensure that the main IE-Node board dipswitch 8 (RTU Node ID Source) is set to the RIGHT position (ON). An internal register will then be used to hold and store a Node ID which can be set via the Modbus TCP connection through the Digi module on the main board.

In order to set the ID, please use the Ethernet Node Network Configurator software. The new address can be in the range 1 – 247.

# TROUBLESHOOTING GUIDE

CONDITION	SOLUTION
CON LED not flashing	Check that the ribbon cable is attached and power is applied.
RS485 LED not flashing / no Modbus RTU connectivity	<ol style="list-style-type: none"> <li>1. Check that CON LED is flashing.</li> <li>2. Check that the master and IE-Node comms are properly wired by matching the comms + and -. Note that A and B may not be consistent between different manufacturers, so always match + and -.</li> </ol>
No power to the sensors	<ol style="list-style-type: none"> <li>1. Check that the field power fuses (F1 - F3) are not damaged.</li> <li>2. Check the field wiring to make sure +24 VDC supply is delivered to the sensors.</li> <li>3. Replace faulty fuses and sensors as necessary.</li> </ol>



# PRODUCT WARRANTY

## 1. EXCLUSIVE WRITTEN LIMITED WARRANTY

ALL PRODUCTS SOLD ARE WARRANTED BY THE COMPANY 4B COMPONENTS LIMITED AND 4B BRAIME COMPONENTS LIMITED HEREIN AFTER REFERRED TO AS 4B TO THE ORIGINAL PURCHASER AGAINST DEFECTS IN WORKMANSHIP OR MATERIALS UNDER NORMAL USE FOR ONE (1) YEAR AFTER DATE OF PURCHASE FROM 4B. ANY PRODUCT DETERMINED BY 4B AT ITS SOLE DISCRETION TO BE DEFECTIVE IN MATERIAL OR WORKMANSHIP AND RETURNED TO A 4B BRANCH OR AUTHORIZED SERVICE LOCATION, AS 4B DESIGNATES, SHIPPING COSTS PREPAID, WILL BE, AS THE EXCLUSIVE REMEDY, REPAIRED OR REPLACED AT 4B'S OPTION.

## 2. DISCLAIMER OF IMPLIED WARRANTY

NO WARRANTY OR AFFIRMATION OF FACT, EXPRESSED OR IMPLIED, OTHER THAN AS SET FORTH IN THE EXCLUSIVE WRITTEN LIMITED WARRANTY STATEMENT ABOVE IS MADE OR AUTHORIZED BY 4B. 4B SPECIFICALLY DISCLAIMS ANY LIABILITY FOR PRODUCT DEFECT CLAIMS THAT ARE DUE TO PRODUCT MISUSE, ABUSE OR MISAPPLICATIONS, AS AUTHORIZED BY LAW, 4B SPECIFICALLY DISCLAIMS ALL WARRANTIES THAT THE PRODUCT IS FIT OR MERCHANTABLE FOR A PARTICULAR PURPOSE.

## 3. NO WARRANTY "BY SAMPLE OR EXAMPLE"

ALTHOUGH 4B HAS USED REASONABLE EFFORTS TO ACCURATELY ILLUSTRATE AND DESCRIBE THE PRODUCTS IN ITS CATALOGS, LITERATURE, AND WEBSITES, SUCH ILLUSTRATIONS AND DESCRIPTIONS ARE FOR THE SOLE PURPOSE OF PRODUCT IDENTIFICATION AND DO NOT EXPRESS OR IMPLY A WARRANTY AFFIRMATION OF FACT, OF ANY KIND OR A WARRANTY OR AFFIRMATION OF FACT THAT THE PRODUCTS WILL CONFORM TO THEIR RESPECTIVE ILLUSTRATIONS OR DESCRIPTIONS. 4B EXPRESSLY DISCLAIMS ANY WARRANTY OR AFFIRMATION OF FACT, EXPRESSED OR IMPLIED, OTHER THAN AS SET FORTH IN THE EXCLUSIVE WRITTEN LIMITED WARRANTY STATEMENT ABOVE, INCLUDING, WITHOUT LIMITATION, THE IMPLIED WARRANTIES OF MERCHANTABILITY AND FITNESS FOR A PARTICULAR PURPOSE.

## 4. LIMITATION OF DAMAGES

ANY LIABILITY FOR CONSEQUENTIAL, INCIDENTAL, SPECIAL, EXEMPLARY, OR PUNITIVE DAMAGES, OR FOR LOSS OF PROFIT WHETHER DIRECT OR INDIRECT, IS EXPRESSLY DISCLAIMED.

With subsidiaries in North America, Europe, China, Asia, Africa and Australia along with a worldwide network of distributors, 4B can provide practical solutions for all your applications no matter the location.



**4B BRAIME COMPONENTS LTD.**

Hunslet Road  
Leeds  
LS10 1JZ  
United Kingdom  
Tel: +44 (0) 113 246 1800  
Email: 4b-uk@go4b.com

**4B DEUTSCHLAND**

35 Bis Rue Du 8 Mai 1945  
80800 Villers, Bretonneux  
France  
Tel: +49 (0) 700 2242 4091  
Email: 4b-deutschland@go4b.com

**4B AFRICA**

14 Newport Business Park  
Mica Drive, Kya Sand  
2163 Johannesburg  
South Africa  
Tel: +27 (0) 11 708 6114  
Email: 4b-africa@go4b.com

**4B FRANCE**

35 Bis Rue Du 8 Mai 1945  
80800 Villers, Bretonneux  
France  
Tel: +33 (0) 3 22 42 32 26  
Email: 4b-france@go4b.com

**4B COMPONENTS LTD.**

625 Erie Avenue  
Morton, IL 61550  
USA  
Tel: 309-698-5611  
Fax: 309-698-5615

**4B ASIA PACIFIC**

Build No. 899/1 Moo 20  
Soi Chongsiri, Bangplee-Tam  
Ru Road, Tanbon Bangpleeyai,  
Amphur Bangplee,  
Samutprakarn 10540  
Thailand  
Tel: +66 (0) 2 173-4339  
Email: 4b-asiapacific@go4b.com

**4B China**

F1, Building 5A,  
Jintong Industrial Park,  
8 West Lake Road,  
Wujin High & New TDZ,  
Changzhou, Jiangsu, PRC  
Tel: +86-519-88556006  
Email: 4b-china@go4b.com

**4B AUSTRALIA**

Building 1, 41 Bellrick Street  
Acacia Ridge  
Queensland 4110  
Australia  
Tel: +61 (0)7 3216 9365  
Email: 4b-australia@go4b.com



[www.go4b.com](http://www.go4b.com)