

WDB1 Series

Bearing Temperature Sensors

**This Product is No Longer Stocked
(Available on Request only)**

Alternative Replacement: **WDB8 Series**

APPLICATION

For use on any application where bearing temperature monitoring is required.

METHOD OF OPERATION

The WDB 1 series bearing sensors are designed to screw directly into a bearing housing. Each sensor is fitted with a grease zerk to allow lubrication of the bearing without the need for removal of the sensor. The WDB1 series have a 1/8" NPT thread.

Three versions are available; an NTC thermistor or platinum RTD type for continuous temperature monitoring, and a PTC thermistor model with the following trip points (specify when ordering): 50°C, 60°C, 70°C, 80°C, 90°C.

The sensor is supplied with a three meter attached cable and can be connected to a PLC or to a hazard monitoring system, such as 4B's T500 Hotbus Elite, Watchdog Elite, or T400 Elite.

The connections are not polarity sensitive therefore special connection requirements are eliminated, and the cable can be extended in the field.

FEATURES

- ▶ Screw in Positive Mount Installation
- ▶ Grease Zerk for Bearing Lubrication
- ▶ NTC Version - Continuous Temperature
- ▶ PT100 Version - Platinum RTD
- ▶ PTC Version - Trip Points from 50°C to 90°C
- ▶ ATEX and IECEx Zone 20 Approved



WDB1 Series Bearing Sensor
(ATEX / IECEx Approved)



Part Number	Description	Thermistor Type	Thread	ATEX Zone	IECEx
WDB10V3AI	Continuous Temperature Monitoring	NTC	1/8" NTP	20	✓
WDB19V3AI	Continuous Temperature Monitoring	PT100	1/8" NTP	20	✓
WDB11V3AI	50°C Trip Point	PTC	1/8" NTP	20	✓
WDB12V3AI	60°C Trip Point	PTC	1/8" NTP	20	✓
WDB13V3AI	70°C Trip Point	PTC	1/8" NTP	20	✓
WDB14V3AI	80°C Trip Point	PTC	1/8" NTP	20	✓
WDB15V3AI	90°C Trip Point	PTC	1/8" NTP	20	✓

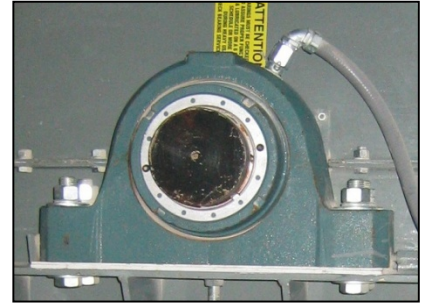
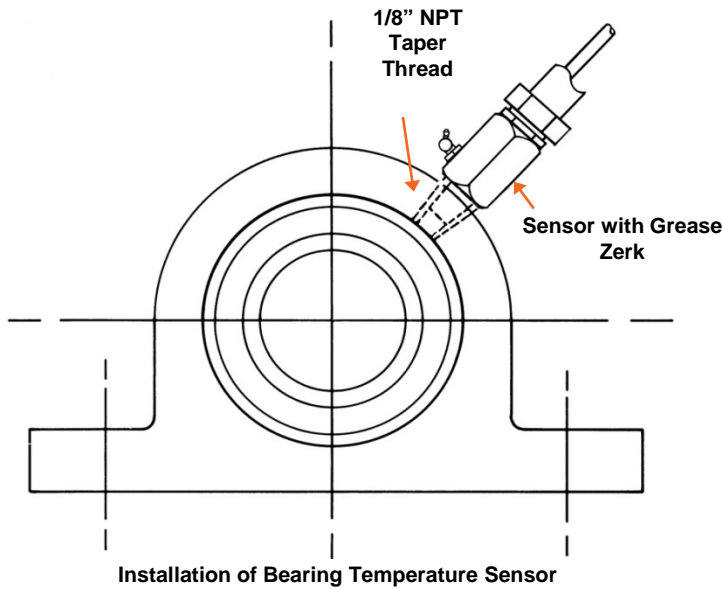

Sensor Installed on Conveyor Bearing



Example of Bearing Failure

TECHNICAL SPECIFICATIONS

WDB1 Series Bearing Temperature Sensors

NTC Sensors	
Resistance at 25°C:	10,000 Ohms
Resistance at 60°C:	2,487 Ohms
Resistance at 90°C:	916 Ohms
Sensing Voltage:	5 to 24 VDC
Current Draw:	1 mA

PTC Sensors	
Resistance at 60°C:	≤ 250 Ohms
Resistance at Trip Point:	≥ 2,000 Ohms
Sensing Voltage:	5 to 25 VDC
Current Draw:	20 mA

PT100 Sensors	
Resistance at 0°C:	100 Ohms
Resistance at 100°C:	138.4 Ohms
Sensing Voltage:	Via Transducer
Current Limit:	1 mA

NOTE: WDB Series 1 sensors have brass bodies and do not have conduit entries.

Temperature Sensors can be used with the following 4B Hazard Monitoring Systems



T500 Hotbus Elite



Watchdog Elite



T400 Elite

Detailed specification, wiring diagrams and installation/operating instructions available upon request.