

## Watchdog™ Elite

### Bucket Elevator & Conveyor Hazard Monitor



#### APPLICATION

Combined belt alignment, belt speed, continuous bearing temperature, pulley alignment and plug condition monitor for bucket elevators and conveyors.

#### METHOD OF OPERATION

The Watchdog Elite system incorporates the latest dual PIC microprocessors and non-volatile (EEPROM) memory chips. An LCD screen displays elevator status messages (available in 4 different languages) and a super-bright LED display shows belt speed. Calibration and set-up parameters are accessed via a password and front panel touch buttons.

#### FEATURES

- ▶ **Belt Speed Monitoring**
- ▶ **Belt Alignment Monitoring**
- ▶ **Bearing Temperature Monitoring**
- ▶ **Pulley Alignment Monitoring**
- ▶ **Plug Condition Monitoring**
- ▶ **Acceleration Monitoring**
- ▶ **LED Displays**
- ▶ **RS485 Serial Communication (Standard)**
- ▶ **PLC Interface (Optional)**

#### WATCHDOG PART NUMBERS

- ▶ WDC3NV46CAI Multi-Voltage Model  
(110Vac/240Vac 50/60Hz and 24Vdc)
- ▶ WDC3NV4CAI 24Vdc only Model

#### ACCESSORIES

- ▶ TS1V4AI Touchswitch - Belt Alignment
- ▶ BS15V10AI Binswitch - Level/Plug
- ▶ ATS6V0FC-FP Autoset Flush Probe - Level/Plug
- ▶ WDA3V34CAI WDA Motion Alignment Sensor
- ▶ HTAS1V34 WDA Motion Alignment Sensor (High Temp.)
- ▶ P300V34AI P300 - Proxswitch
- ▶ WDB810V3AI NTC Bearing Temperature Sensor
- ▶ WDB70V3AI Surface Mount Temperature Sensor
- ▶ ADB810V3AI NTC Adjustable Depth Bearing Temp. Sensor - 4 Inch Probe
- ▶ ADB810V3AI/D2 NTC Adjustable Depth Bearing Temp. Sensor - 2 Inch Probe
- ▶ ADB810V3AI/D8 NTC Adjustable Depth Bearing Temp. Sensor - 8 Inch Probe
- ▶ WDPLCB2V4C PLC Alarm Relay Interface
- ▶ F5004V46CAI F500 Fieldbus Gateway\*



\* Available Gateways (Must Specify) - Ethernet, DeviceNet, Profibus, Modbus

## Bucket Elevator Application A (Plastic Or Steel Elevator Buckets)

### Belt Misalignment



#### Touchswitch -

Contact type electro-mechanical limit-switch with no moving parts, which detects tracking and misalignment problems.

6

### Plug Condition



#### Binswitch -

Capacitance style sensor that can detect plugged spouts, inlets and outlets.

3

#### Autoset Flush Probe -

Heavy duty capacitance style sensor with automatic material build up compensator that can detect plugged spouts, inlets and outlets.



8

### Bearing & Surface Temperature



#### ADB & WDB Series -

1. Grease through, positive mounting, NTC thermistor with user adjustable trip points. ADB series has adjustable depth probes.

2. Surface mount NTC thermistor designed to bolt onto a bearing or gearbox housing.

1

### Speed Monitoring



#### Proxswitch -

Industry standard inductive sensor for detecting belt slip conditions. Shown on boot shaft with the optional Whirligig target/bracket/guard for easy installation.

7

#### Rotech Encoder -

Heavy duty option for monitoring underspeed and belt slip conditions. Made from cast aluminum, the Rotech is used in the most severe industrial environments.



9

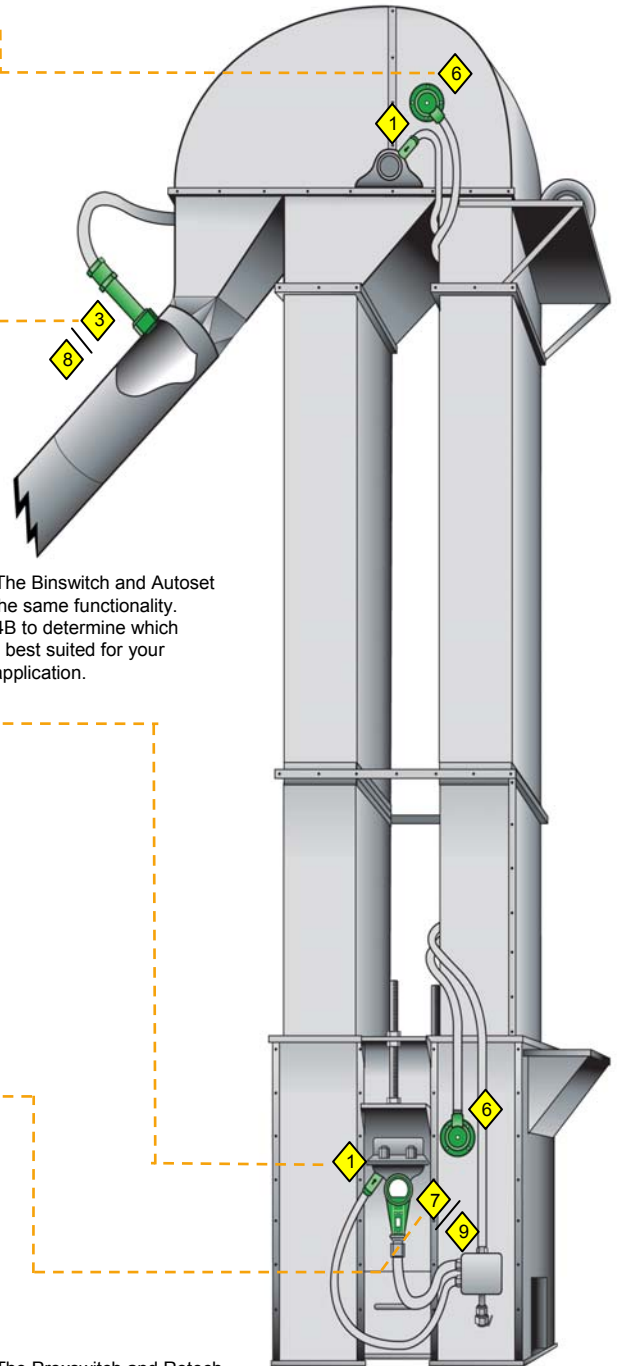

**NOTE:** The Binswitch and Autoset provide the same functionality. Consult 4B to determine which sensor is best suited for your specific application.

**NOTE:** The Proxswitch and Rotech Encoder provide the same functionality. Consult 4B to determine which sensor is best suited for your specific application.

Please refer to instruction manual for correct installation. Information subject to change or correction. April 2013

# Watchdog Elite

BETTER BY DESIGN

## Bucket Elevator Application B (Steel Elevator Buckets)

### Motion (Speed) & Alignment



#### WDA Sensor -

Non-contacting extended range sensor used to detect targets which are up to 4 inches from the sensor. High temperature version available (302°F continuous, 356°F max.).

5

### Plug Condition



#### Binswitch -

Capacitance style sensor that can detect plugged spouts, inlets and outlets.

3

#### Autoset Flush Probe -

Heavy duty capacitance style sensor with automatic material build up compensator that can detect plugged spouts, inlets and outlets.



8

### Bearing & Surface Temperature



#### ADB & WDB Series -

- Grease through, positive mounting, NTC thermistor with user adjustable trip points. ADB series has adjustable depth probes.
- Surface mount NTC thermistor designed to bolt onto a bearing or gearbox housing.

1

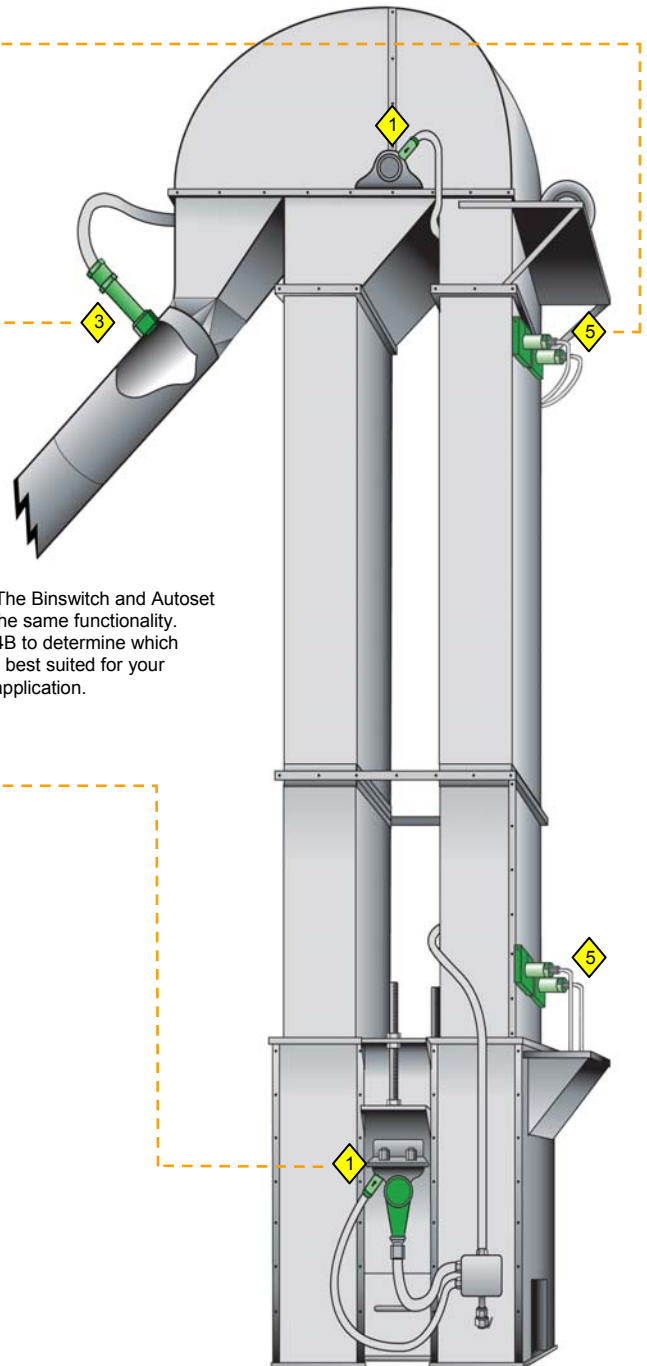

**NOTE:** The Binswitch and Autoset provide the same functionality. Consult 4B to determine which sensor is best suited for your specific application.

## Standard Conveyor Application (Open & Enclosed)

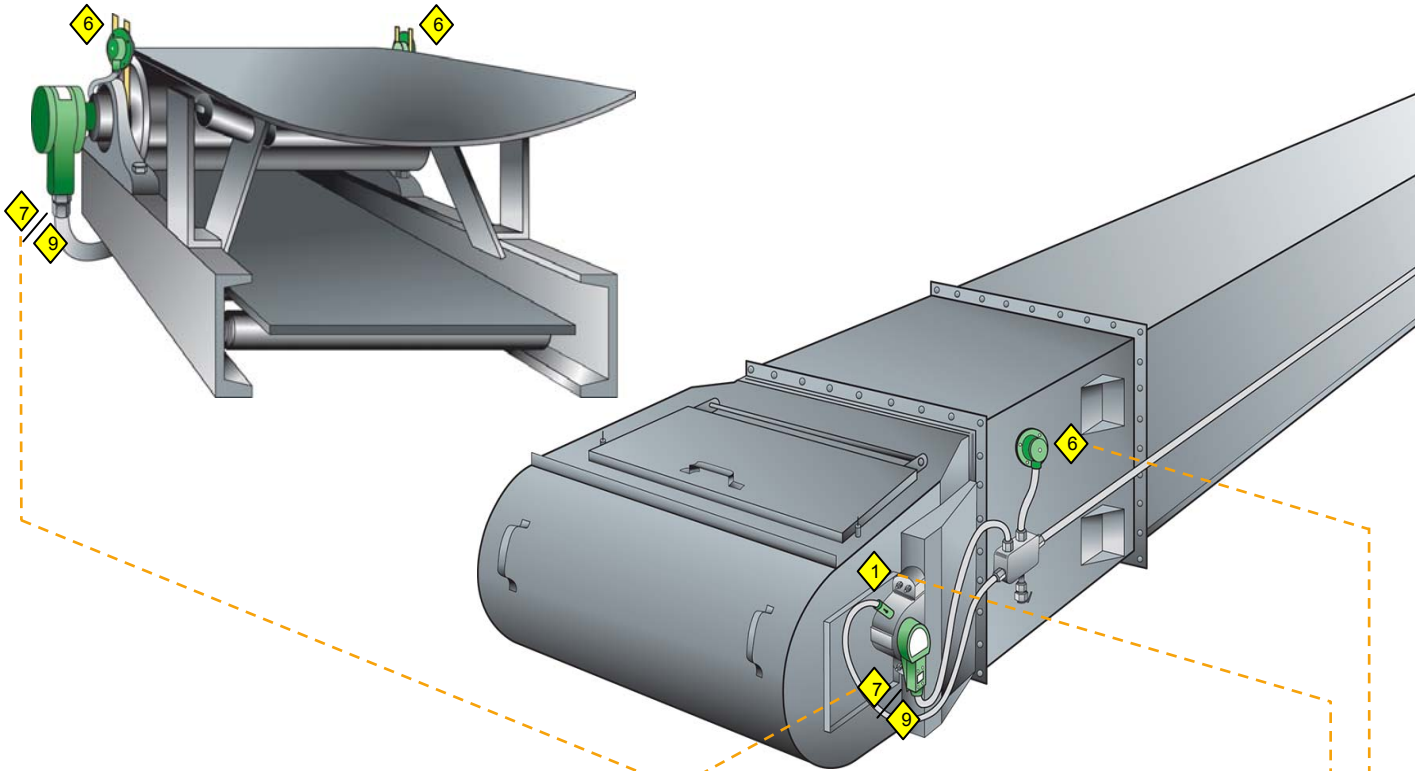

### Speed Monitoring

#### Rotech Encoder -

Heavy duty option for monitoring underspeed and belt slip conditions. Made from cast aluminum, the Rotech is used in the most severe industrial environments.



#### Proxswitch -

Industry standard inductive sensor for detecting belt slip conditions. Shown on boot shaft with the optional Whirligig target/bracket/guard for easy installation.



**NOTE:** The Proxswitch and Rotech Encoder provide the same functionality. Consult 4B to determine which sensor is best suited for your specific application.

### Bearing & Surface Temperature

#### ADB & WDB Series -



1. Grease through, positive mounting, NTC thermistor with user adjustable trip points. ADB series has adjustable depth probes.
2. Surface mount NTC thermistor designed to bolt onto a bearing or gearbox housing.

### Belt Misalignment

#### Touchswitch -

Contact type electro-mechanical limit-switch with no moving parts, which detects tracking and misalignment problems.



Please refer to instruction manual for correct installation. Information subject to change or correction. April 2013

## TECHNICAL SPECIFICATIONS



Watchdog Control Unit	
<b>Power Supply:</b>	WDC3NV46CAI - 110 VAC, 240 VAC (50/60 Hz) or 24 VDC WDC3NV4CAI - 24VDC ONLY
<b>Power Consumption:</b>	18 VA
<b>Alarm &amp; Stop Relay:</b>	2x Voltage Free Relay Contact (Changeover) Max 10A / 240 VAC
<b>Sensor Inputs:</b>	4 x 24 VDC Digital (Alignment + Speed) 6 x 24 VDC Analog (NTC Temperatures) 1 x RS485 Com. Port (F500 Connection)
<b>Sensor Supply:</b>	24 VDC, 100 mA Available
<b>Speed Range:</b>	20 - 4,000 Pulses/Minute
<b>Construction:</b>	Polycarbonate Enclosure w ith IP66 / NEMA 4X
<b>Dimensions:</b>	11" x 10" x 5" (28cm x 25cm x 13cm)
<b>Conduit Entries:</b>	2 x 25mm DIA.
<b>Approval:</b>	A TEX and IECEx Zone 21 (WDC3NV4CAI) A TEX and IECEx Zone 22 (WDC3NV46CAI) CSA Class II, Division 2 - F, G (USA) CSA Class II, Division 1 - E, F, G (Canada) GOST-R (Russia and CIS Countries)