

Encoder-Flex 1024

Rotary Shaft Encoder and Gate Position Monitor

APPLICATION

The Encoder-Flex 1024 is a rotary shaft encoder that monitors slide gate position, shaft position, or shaft speed. Examples include position of rack and pinion gates, valves, distributors, and shaft speed on rotating shafts such as slow moving conveyors, mixers, and dryers.

METHOD OF OPERATION

The Encoder-Flex 1024 uses innovative technology to monitor gate position or shaft speed. The resolution is programmable from 1-1024 pulses per revolution and it consists of 4-20 mA output as well as quadrature pulsed output for directional speed, and a Modbus RTU communications for advanced configuration and diagnostics.

There are two status LEDs for easy identification of operational mode and target detection. The unit is quickly calibrated with the touch of a magnet for shaft speed, angular shaft position, or gate position. The sealed body is constructed from stainless steel.

Output signals can be wired to a PLC, SCADA system, or other controller for accurate display and control of shaft position and speed.



FEATURES

- ▶ Monitors shaft speed, angle, or position
- ▶ Outputs: 4-20 mA, Quadrature Pulse (Speed/Relative Rotation), and RS485 Modbus RTU
- ▶ Programmable resolution from 1 to 1024 Pulses per Revolution
- ▶ Compatible with gates with up to 500,000 rotations between closed and open positions
- ▶ Connects directly to control systems (PLC, SCADA, Watchdog, IE-Node, etc)
- ▶ Memorizes shaft position in the case of a power loss
- ▶ Simple magnetic calibration
- ▶ Comprehensive software for access to advanced programming and visualization
- ▶ Sealed stainless steel enclosure
- ▶ LED Status Indicators
- ▶ ATEX, IECEx, UKEx Zone 20 Approved
- ▶ Class II Div 1 Approved

PART NUMBERS/ACCESSORIES

- | | |
|----------------------|--|
| ▶ EFLEX10242V34CAI/0 | Encoder-Flex 1024 – M12 Shaft |
| ▶ EFLEX10242V34CAI/1 | Encoder-Flex 1024 – ½" UNC Shaft |
| ▶ EFLEX10242V34CAI/2 | Encoder-Flex 1024 – D-Type Shaft |
| ▶ PTD110V6 | Process Tech Display 100-240 VAC with 24VDC sensor power |
| ▶ PTD100V4 | Process Tech Display 24 VDC Display Only |
| ▶ USB-RS485-1 | USB To RS485 1' Long Converter |



PTD110V6

ENCODER-FLEX 1024

WIRE DESCRIPTION



BLACK	OV
RED	+V
GREEN	CL OUT
BROWN	PULSE +V
WHITE	PULSE X
BLUE	PULSE Y
YELLOW	RS485 A (DATA +)
ORANGE	RS485 B (DATA -)
BARE COPPER	GROUND DRAIN WIRE

DIMENSIONS

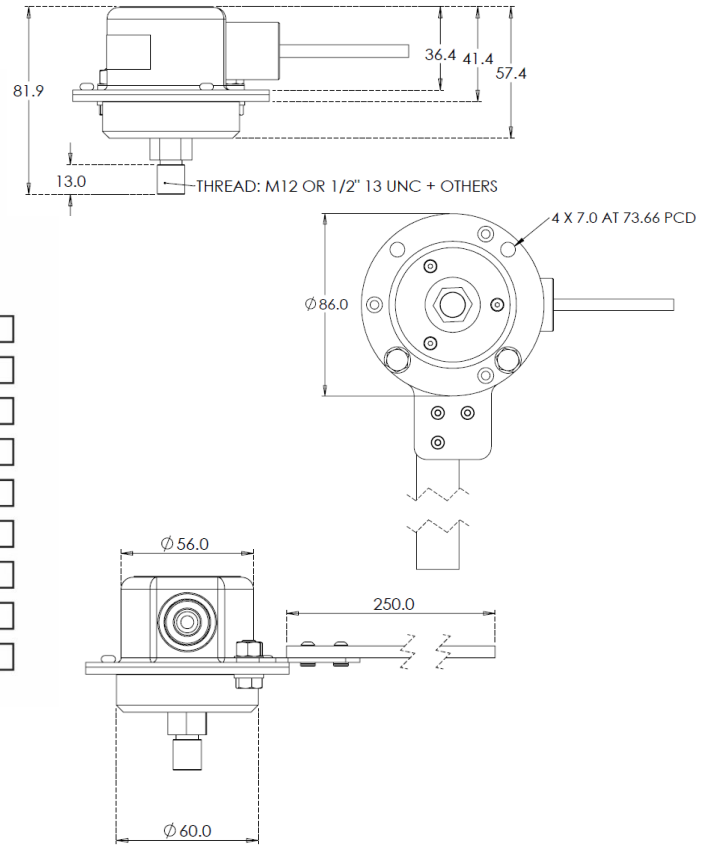

NOTE: Dimensions are in mm

TECHNICAL SPECIFICATIONS

Power Supply	12-24 VDC
Speed Range	0-2,000 RPM (Max Frequency 500 Hz)
Outputs	4-20mA
	Quadrature Pulsed (24VDC Max)
	Modbus RTU
Resolution	Adjustable 1 to 1024 Pulses Per Revolution
Enclosure	304 Stainless Steel
Thread Size	M12 (Other Sizes Available)
Operating Temperature	-30°C (-22°F) to 50°C (122°F)
Cable	3m (9 ft.) – 8 Conductor
Approvals	ATEX, IECEx, UKEx Zone 20 Class II Div 1 Groups E, F & G (US & Canada)
Calibration	Magnetic or PC Software
Conduit Entry	1/2" NPT

Copyright © 2023 4B Group. All rights reserved. Information is subject to change or modification without notice. Refer to instruction manual for installation information. CRD021523