



## Bolt-N-Go™ Drop Forged Chain Assembly Guide for Links and Flights

### HARDWARE SPECIFICATIONS -

The table below lists all of the hardware required to assemble Bolt-N-Go chain in 102NA, 142NA, and 142HA sizes. Torque ranges for the bolts are also provided to ensure proper clamping force.

#	102NA LINK	142NA LINK	142HA LINK
1	4B102BNA	4B142BNA	4B142BHA
2	Nylon Flight	Nylon Flight	Nylon Flight
3	1/4 x 1-3/4 Hex Bolt (Gr. 8) - No Flight	M10 x 65 Hex Bolt (Gr. 10.9) - No Flight	M10 x 85 Hex Bolt (Gr. 10.9) - No Flight
	1/4 x 3-1/2 Hex Bolt (Gr. 8) - Flight	M10 x 120 Hex Bolt (Gr. 10.9) - Flight	M10 x 140 Hex Bolt (Gr. 10.9) - Flight
4	Small Flat Washer (2) - No Flight	Small Flat Washer (2) - No Flight	Small Flat Washer (2) - No Flight
5	Fender Washer (2)	Fender Washer (2)	Fender Washer (2)
6	Wedge Lock Washer (2)	Wedge Lock Washer (2)	Wedge Lock Washer (2)
7	Nylon Insert Lock Nut	Nylon Insert Lock Nut	Nylon Insert Lock Nut
8	Hollow Pin	Hollow Pin	Hollow Pin
---	Torque Bolt to 5 to 6 ft-lb.	Torque Bolt to 20 to 25 ft-lb.	Torque Bolt to 20 to 25 ft-lb.

### ASSEMBLY DIAGRAM -

The diagram below illustrates the assembly for both flighted and non-flighted links. Note that the hollow pin (#8) keeps the chain tensioned when adding or removing flights.

#### FLIGHTED LINKS -

- » Align flight slot to engage with the link lug to prevent rotation.
- » Bolt (3) → Wedge Lock (6) → Flight (2) → Hollow Pin (8) → Flight (2) → Wedge Lock (6) → Lock Nut (7)
- » After tightening, ensure that the connected links articulate freely.

#### NON-FLIGHTED LINKS -

- » Bolt (3) → Fender (5) → Flat Washer (4) → Hollow Pin (8) → Flat Washer (4) → Fender (5) → Lock Nut (7)

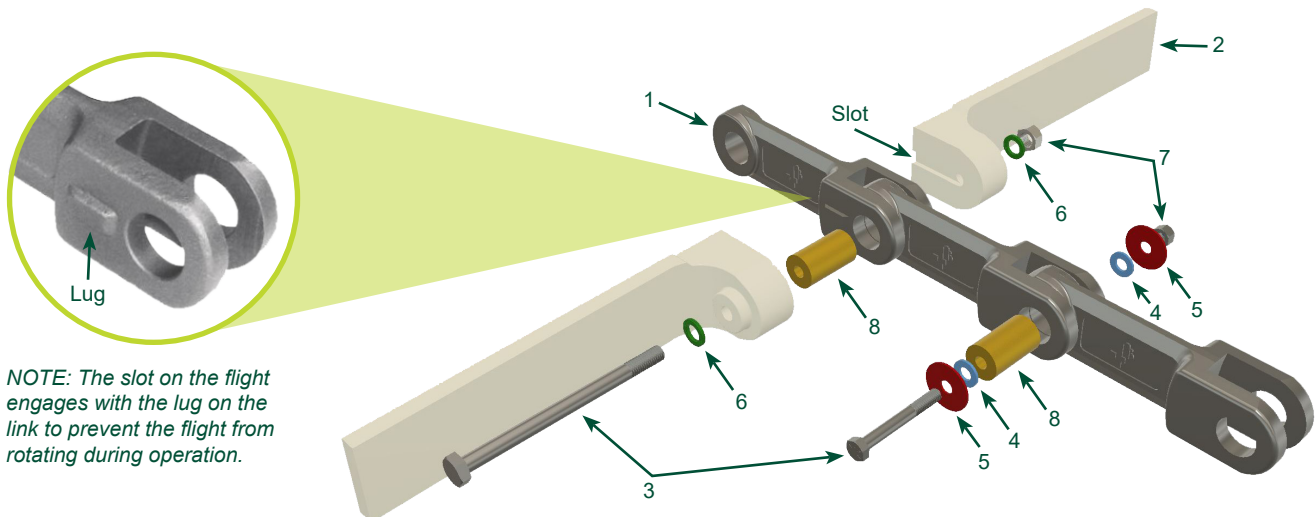

*NOTE: The slot on the flight engages with the lug on the link to prevent the flight from rotating during operation.*



## Bolt-N-Go™ Drop Forged Chain Assembly Guide for Links and Flights

### INSTALLATION AND MAINTENANCE -

- » Always follow proper safety procedures for chain installation.
- » After installation, run the conveyor without product for several revolutions. Check that the chain and flights are secure.
- » If no issues are found, run the conveyor with material for 3 hours. Check the chain and flights again to make sure they are secure.
- » Periodically inspect the chain, flights and bolt torque settings.
- » For installation questions or assistance, contact 4B.



*Example of Bolt-N-Go Chain Assembly  
with Flights on Every 2nd Pitch*

<b>⚠ DANGER</b>
Exposed moving parts will cause severe injury or death. Lockout power before removing cover or inspection door.

<b>⚠ WARNING</b>
Moving parts can crush and cut. Lockout power before removing guard or servicing. Do NOT operate with guard removed