



# **ELEVATOR BELT & BELT SPLICE INSTALLATION GUIDE**

**Textile & Steel Web Belting  
(Revision 3)**

[www.go4b.com](http://www.go4b.com) —

## TABLE OF CONTENTS

Textile Elevator Belt Installation	
- General Information.....	Page 3
- Tools & Equipment Required.....	Page 3
- Installation.....	Page 3 - 5
Installation of Light Narrow Belts.....	Page 6
Installing the Buckets.....	Page 6
Monitoring System.....	Page 6
Steel Web Core Elevator Belt Installation	
- General Information.....	Page 7
- Tools & Equipment Required.....	Page 7
- Installation.....	Page 7 - 11
Installing the Buckets.....	Page 11
Monitoring System.....	Page 11
Appendix - A	
- 550 & 800 Wide Belts.....	Page 12
Appendix - B	
- Gripwell & Supergrip 1 Splices.....	Page 13
Appendix - C	
- Supergrip 2 Splice.....	Page 14
Appendix - D	
- Supergrip 3 Splice.....	Page 15
Appendix - E	
- Supergrip 4 Splice.....	Page 16
Appendix - F	
- 4B Vise Splice Installation.....	Page 17

## TEXTILE ELEVATOR BELT INSTALLATION WITH BRAIME CLAMP AND SUPERGRIP SPLICES & FASTENERS

This guide is intended to assist with the correct installation of Braime Clamp (style #1) and Supergrip (style #2, #3 and #4) belt splices and fasteners.

**Before commencing any work, advice should be sought from your safety advisor and relevant personal. Only skilled fitters should assemble the belt and belt connectors.**

**All safety instructions must be followed explicitly and protective equipment should be worn at all times. Lock out and tag out procedures must be strictly enforced.**

### GENERAL INFORMATION

The elevator belt is in a roll and should be treated with care. The roll should not be unloaded by dropping onto rough ground and should not be rolled on rough ground. Storage should be in a dry environment away from sunlight, UV lighting, ozone, oils, acids and solvents.

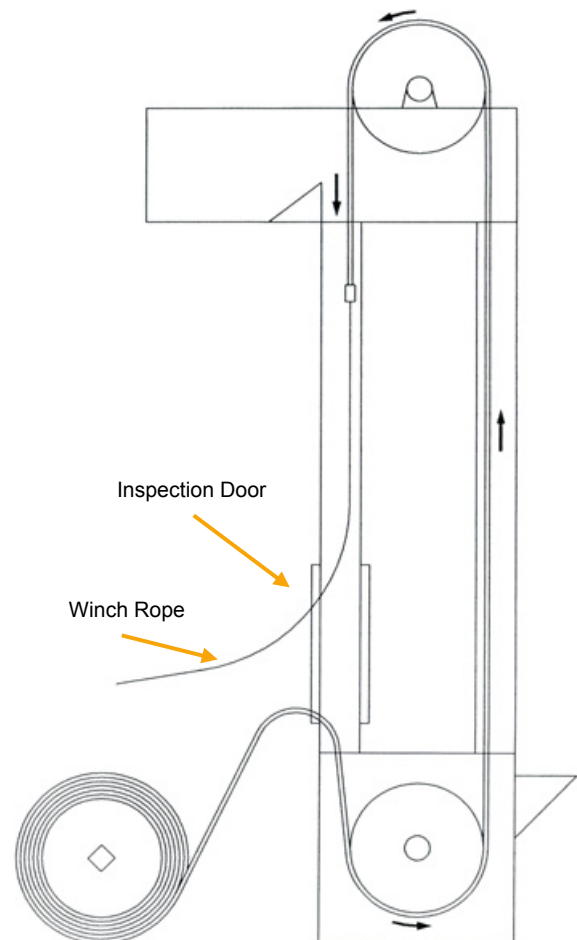
### TOOLS & EQUIPMENT REQUIRED

- Belting cross beams with D shackle location holes positioned 50 mm wider than the belt
- 2 x 1.5 ton chain blocks or 2 adequately strong screw turnbuckles
- Electric or pneumatic drill with 14 mm and 16 mm diameter bits
- D shackles
- M14 and M16 threaded rods - 300 mm long with a nut welded to one end of each rod
- M14 and M16 sockets, ring spanners, and torque wrench

### INSTALLATION

Remove the head cover and the inspection doors immediately above the boot. The inspection doors should be about 70 mm wider than the belt for ease of access. Lift the elevator boot pulley to its highest position. Isolate the elevator drive and electric power in the elevator. Position the elevator belt in front of the down side inspection doors above the boot.

Prepare one end of the elevator belt about 400 mm from the end to accept the Braime Clamp 1 sections or either the no. 2 and no. 3 belt fasteners at 50 mm each shoulder to shoulder. If using no. 4 belt fasteners, 80 mm shoulder to shoulder. Start from the middle by using



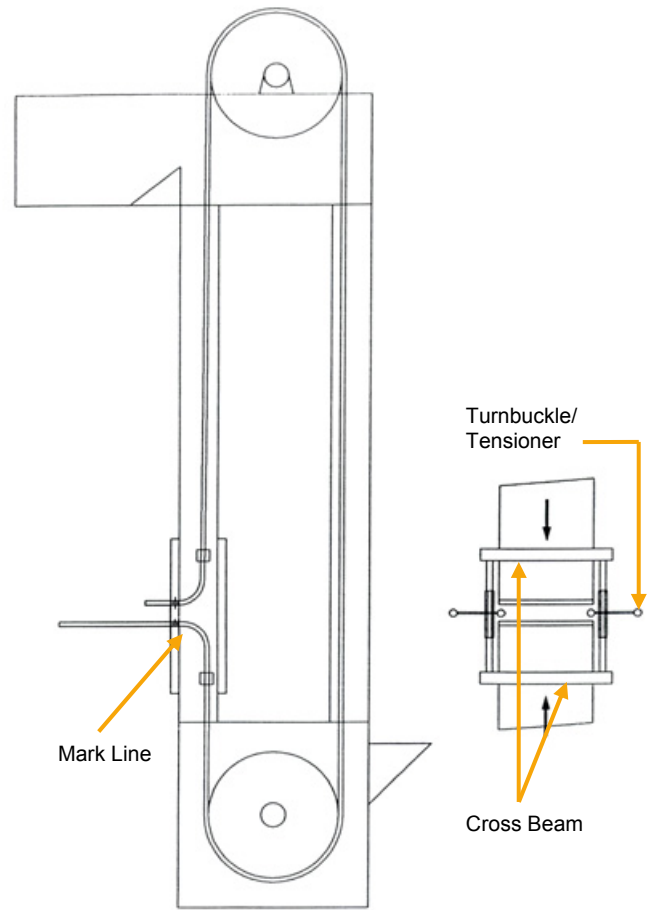
**Figure 1**

a 3 mm thick steel template with pre-drilled holes as required for the belt fastener. The template must be at an exact right angle to the belt side. When correctly positioned, drill the mounting holes through the template in the belt end.

Lift the belt by means of cross beams and shackles into the elevator by means of a winch, threading the belt under the boot pulley, up over the head pulley and down the down side to the inspection door. Or use a crane, lowering the belt down from the head pulley (**figure 1**). Ensure that the prepared end is uppermost at the inspection door.

Position both ends of the belt within close proximity to the inspection door.

Fasten a cross beam, by means of bucket belts, to the both the upper and lower belt ends about one meter away from the proposed joint. With either a chain block or turnbuckle on each side of the cross beam, pull the prepared end and the loose end together, taking up the slack. Then just through the inspection door, bend the prepared end and the lower end together. Mark a line across and at right angles to the side of the lower belt opposite the center line of the upper fastener mounting holes (**figure 2**).



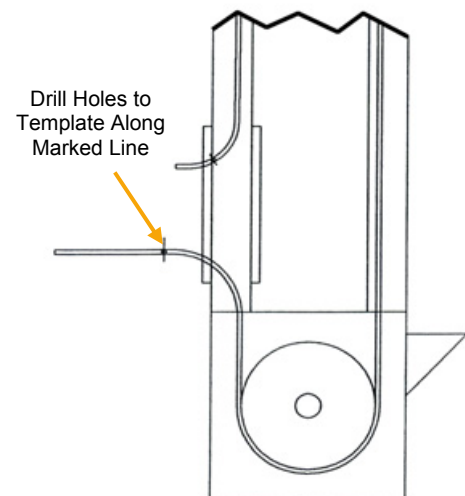
**Figure 2**

Loosen the turnbuckles a small amount and bend out the lower belt end through the inspection door (**figure 3**). With the template at right angles to the belt side, drill the fastener mounting holes. Use an engineers square to accurately set the template (**figure 3**).

Secure the two ends of the belt together by tightening up the chain blocks or turnbuckles. Ensure that when pulling the two ends of the belt together, an even tension on each side of the belt is applied (**figure 2**).

Fold out the belt ends and assemble to the Braime Clamp 1 and Supergrip belt fastener blocks or the No. 4 fastener segments to the belt ends with the tongue part between the belts. Starting with the center, use the 300 mm threaded rods to initially pull the parts together (**figure 4**).

Check that all the fastener blocks are in line and installed. Tighten all the bolts and nuts into the fasteners. Then remove the threaded rods and replace with bolts and nuts.



**Figure 3**

## Braille Clamp 1

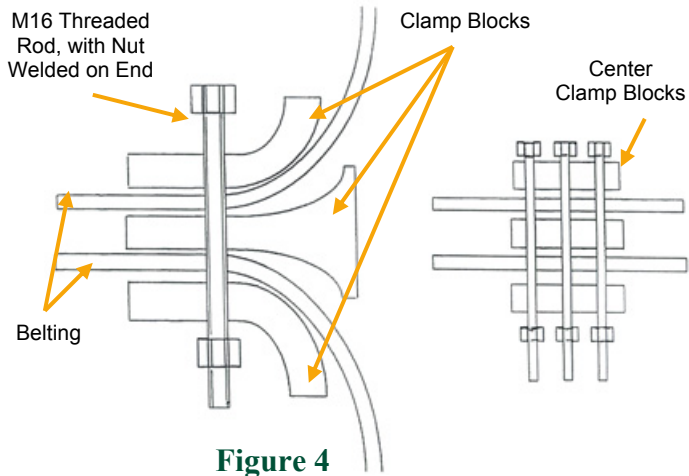


Figure 4

View the side of the fasteners and check that all are square. Re-tighten all the bolts, starting from the center outwards. For 16mm bolts torque to 252 nm. For 14 mm bolts torque to 162 nm.

Cut off the spare loose ends of the belt about 50 mm from the belt fasteners (Figure 5 & 6).

Remove the tension on the chain blocks or turn buckles and remove the belt cross beams. Then apply tension to the belt by adjusting the belt take up device as fitted to the elevator.

Run the belt round with the inching or pony slow drive, tracking and tension the belt accordingly.

Once the belt has been tensioned and tracked centrally, run the belt at full speed for 30 minutes. At the end of this period stop the belt and with the inching drive, position the belt fastener within the inspection doors. After locking out and tagging out the elevator and undertaking additional safety precautions, re-check the bolt tensions with a torque wrench starting from the center bolts and working alternatively towards the outside of the belt.

The belt fasteners should be checked every month to ensure the correct torque.

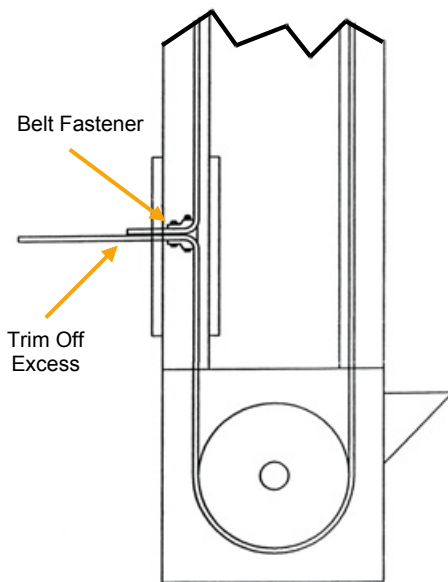


Figure 5

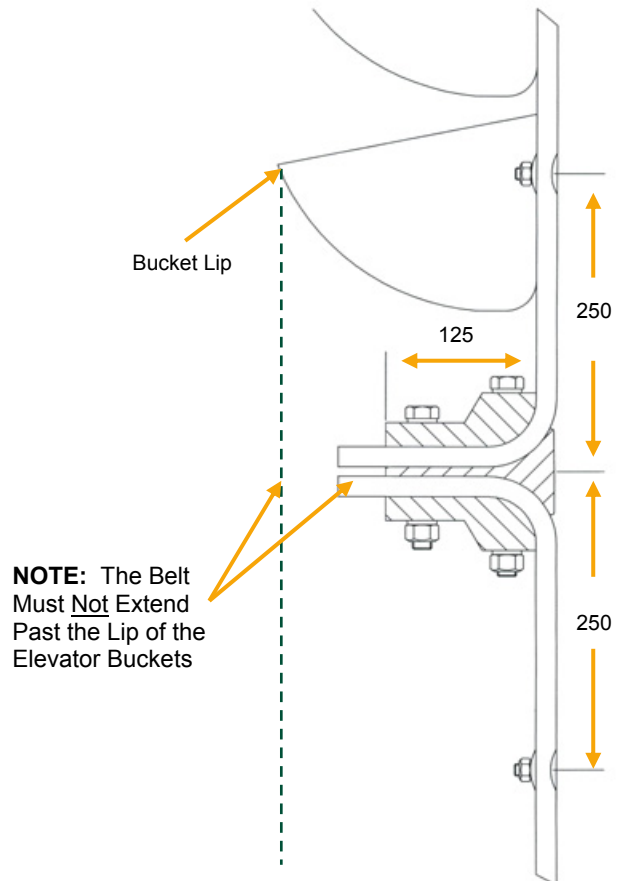


Figure 6

## **INSTALLATION OF LIGHT NARROW BELTS**

Lift the boot pulley up to its highest point in the boot; prepare one belt end with the holes for the fasteners.

Install the belt into the elevator with the two belt ends situated at the lower inspection doors. Overlap the two ends and attach two cross beams about 150 mm apart, make sure the cross beams are secure. Attach chain blocks or adjustable turn buckles to the cross beams, one on the top part of the belt and one on the bottom part of the belt. Tighten the blocks or turn buckles until the belt is tight and the two ends are easy to fold out to work on.

Bend out the prepared belt end and bend out the other end immediately under the prepared end. Mark out and drill the lower belt fastener holes at right angles to the top belt side. It is essential that the fasteners are at right angles to the belt, other wise the belt will not track correctly. Clamp the belt fasteners to the belt with the tongue part in between the belts. Then using the 300 mm screwed rods, install the bolts starting at the middle of the belt. Fasten and torque all of the bolts, starting from the center outwards. For 16mm bolts torque to 252 nm. For 14 mm bolts torque to 162 nm.

## **INSTALLING THE BUCKETS**

Install the buckets to the belt in sections, so as not to unbalance the whole assembly. Make sure to torque the bucket bolts to the required tension. When all the buckets are installed, operate the elevator on full load for about 12 hours, and then check that the belt is running centrally on the pulleys. Make sure to double check and re-tighten all the bucket bolts.

Check the bucket bolt torque once a month.

## **MONITORING SYSTEM**

The installation of a bucket elevator monitoring system is recommended. A system such as a Watchdog Elite will monitor for belt slippage, belt misalignment, hot bearings, head pulley misalignment and plugged chute conditions. The system should be installed to automatically shutdown the bucket elevator when a hazardous condition is detected.

## **STEEL WEB ELEVATOR BELT INSTALLATION WITH BRAIME CLAMP 1, 2 AND 3 BELT SPLICES & FASTENERS**

This guide is intended to assist with the correct installation of steel web belts using Braime Clamp (style #1, #2 or #3) belt splices and fasteners.

**Before commencing any work, advice should be sought from your safety advisor and relevant personal. Only skilled fitters should assemble the belt and belt connectors.**

**All safety instructions must be followed explicitly and protective equipment should be worn at all times. Lock out and tag out procedures must be strictly enforced.**

### **GENERAL INFORMATION**

The elevator belt is in a roll and should be treated with care. The roll should not be unloaded by dropping onto rough ground and should not be rolled on rough ground. Storage should be in a dry environment away from sunlight, UV lighting, ozone, oils, acids and solvents.

### **TOOLS & EQUIPMENT REQUIRED**

- Belting cross beams with D shackle location holes positioned 50 mm wider than the belt
- 2 x 1.5 ton chain blocks or 2 adequately strong screw turnbuckles
- Electric or pneumatic drill with 14 mm and 16 mm diameter bits
- D shackles
- M14 and M16 threaded rods - 300 mm long with a nut welded to one end of each rod
- M14 and M16 sockets, ring spanners, and torque wrench

### **INSTALLATION**

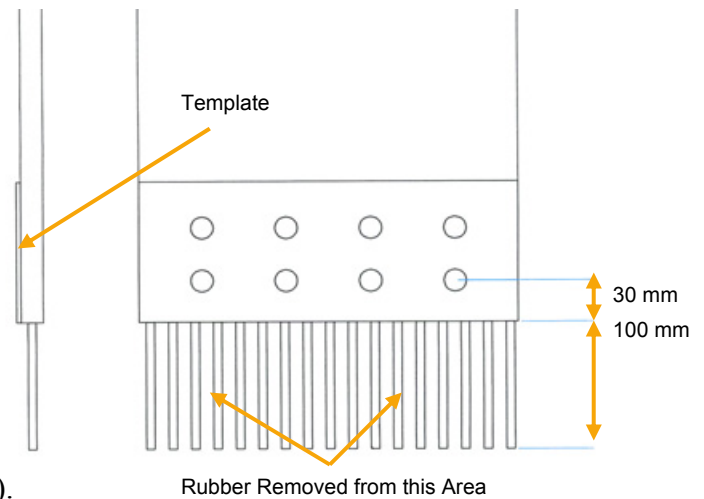
Remove the head cover and the inspection doors immediately above the boot. The inspection doors should be about 70 mm wider than the belt for ease of access. Lift the elevator boot pulley to its highest position. Isolate the elevator drive and electric power in the elevator. Put the belt on an axle and on jacks, select a suitable axle thickness conforming to the roll weight. Check correct height of jacks conforming to roll diameter. The belt is best uncoiled from underneath rather than over the top. This offers less risk of the coil being dragged off the jacks. Position the elevator belt in front of the down side inspection doors above the boot. Make sure the belt is fed into the elevator in the correct running direction and make sure the pulley side is running over the pulley face. The belts are marked with a running direction arrow and an indication of pulley face and bucket face.

Before the belt is pulled in the elevator, the quality and condition of the rubber lagging on the drive pulley, as well as the condition of the tail pulley will have to be inspected and approved. In the case of older elevators, check that the pulley crown is still correct and in the case of flat pulleys, check that the pulley face has not worn hollow.

Please consult our technical department for recommendations of the height of the pulley crown. Make sure that all equipment used is capable of handling the belt weight.

Prepare one end of the elevator belt about 400 mm from the belt end to accept either the Braime Clamp 1, 2 or 3 belt fastener sections shoulder to shoulder starting from the middle. Drill the bolt holes by using a steel template with pre-drilled holes as required for the aluminum part of the fasteners. The template must be at an exact right angle to the belt side and positioned at 150 mm for the belt end.

Starting at 30 mm from the rear most holes of the template, carefully bare 100mm of rubber from each face of the wire core using a sander or a sharp knife, cutting off the rubber in strips (**figure A**). A RC-400 rubbercut electrical groover (as used to re-cut grooves in car tires) can also be used. Damage to the steel cables must be avoided.



**Figure A**

Then remove the weft cables carefully (these are the cables in the width of the belt). These weft cables are laying on top and underneath the warp (length) cables and are positioned at 6.67 mm pitch.

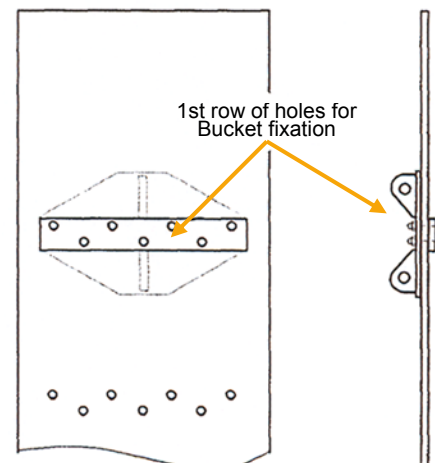
Weft and warp cables are locked together by a polyester thread, which can be split together with the binding rubber by using a sharp knife. Preferably use a knife shaped like a pointing trowel or a RC-400 rubbercut electrical groover. Grinding is possible but high speeds produce unpleasant vapors and may cut too deeply into the belt body damaging the cables. This must be avoided.

Do not damage the warp (length) cables! Leave a thin rubber layer visible on the warp (length) cables and avoid red or copper colored spots on the cables. Do not take too much rubber off and take care that the warp (length) cables are still bonded together by a layer of rubber.

It is recommended to fit traction eyes and cross beams to both belt ends as aids for dragging the belt into the elevator and for securing the belt into a fixed position. Fit the plate assembly through the bucket holes (**figure B**).

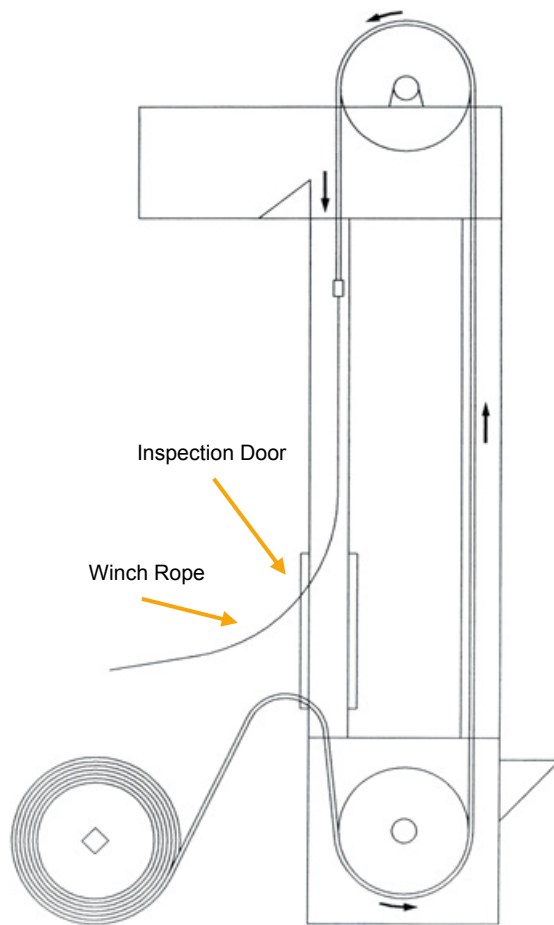
Lift the belt by means of cross beams and shackles into the elevator by means of a winch, threading the belt under the boot pulley, up over the head pulley and down the down side to the inspection door (**figure C**). Or use a crane, lowering the belt down from the head pulley. Ensure that the prepared end is uppermost at the inspection door.

Position both ends of the belt within close proximity to the inspection door.

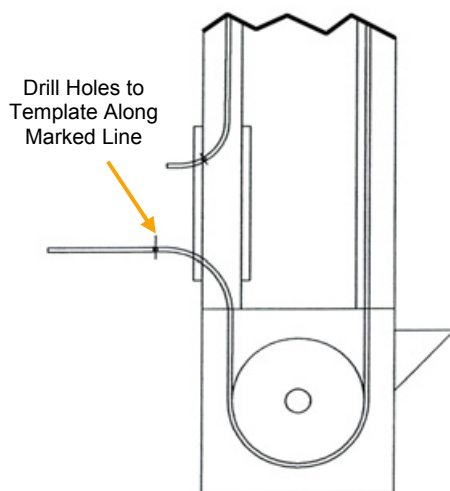


**Figure B**





**Figure C**



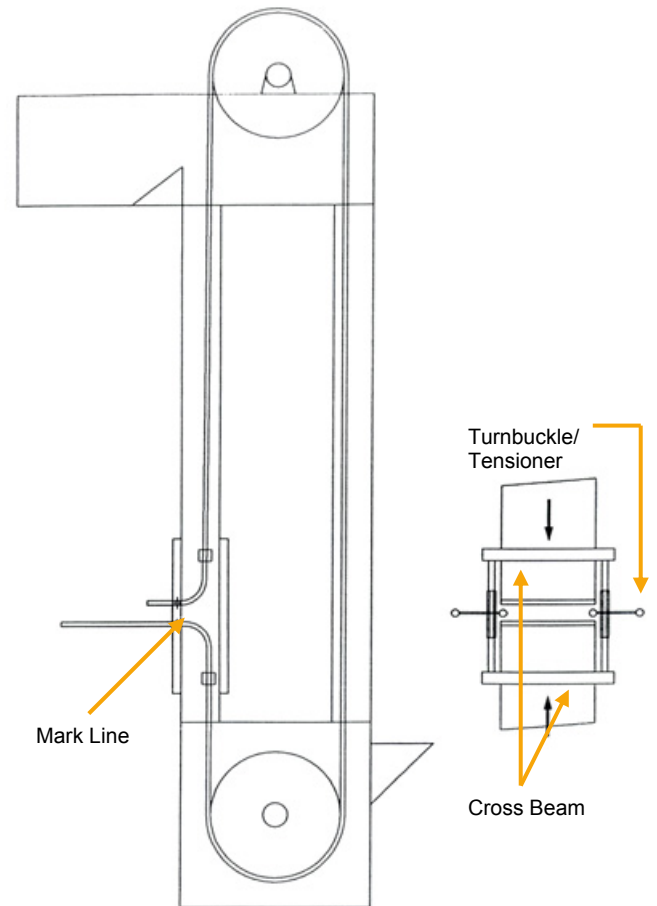
**Figure E**

Fasten a cross beam, if not already done, to the both the upper and lower belt ends about one meter away from the proposed joint. With either a chain block or turnbuckle on each side of the cross beam, pull the prepared end and the loose end together, taking up the slack. Then just through the inspection door, bend the prepared end and the lower end together. Mark a line across and at right angles to the side of the lower belt opposite the center line of the upper fastener mounting holes (**figure D**).

Loosen the turnbuckles a small amount and bend out the lower belt end through the inspection door (**figure E**).

With the template at right angles to the belt side, drill the fastener mounting holes. Use an engineers square to accurately set the template (**figure E**).

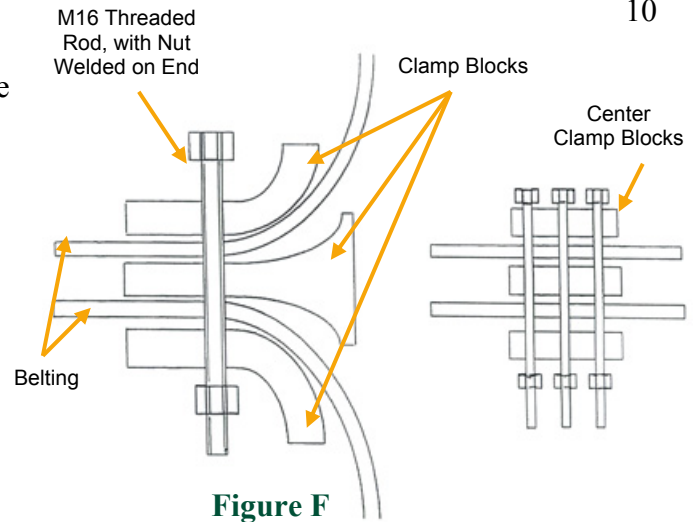
Secure the two ends of the belt together by tightening up the chain blocks or turnbuckles. Ensure that when pulling the two ends of the belt together, an even tension on each side of the belt is applied (**figure D**).



**Figure D**

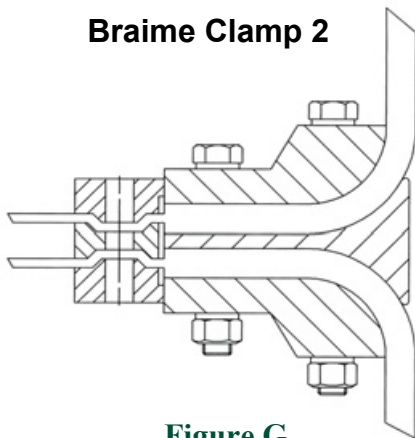
Fold out the belt ends and assemble to the Braime Clamp belt fastener blocks with the tongue part between the belts. Starting with the center, use the 300 mm threaded rods to initially pull the parts together (**figure F**).

Check that all the fastener blocks are in line and installed. Tighten all the bolts and nuts into the fasteners. Then remove the threaded rods and replace with bolts and nuts.

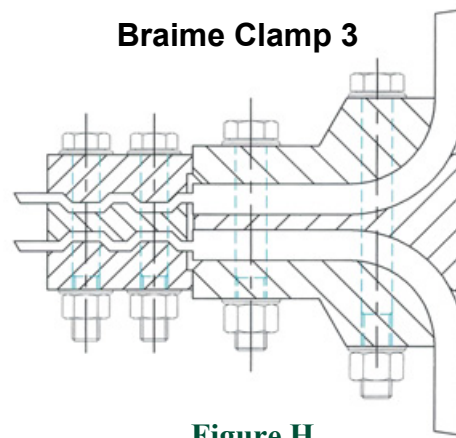


**Figure F**

To install the steel clamp parts of the fasteners, bare 100 mm of rubber from each face of the wire cores of the lower belt end as described earlier. Install the three related steel parts on the wire cores behind each aluminum clamp block, with G clamps, ensuring that the parts butt up against the aluminum first part. Then drill through the steel clamps and wire cores, and install the fastener bolts and nuts (**figure G or H**).



**Figure G**



**Figure H**

View the side of the fasteners and check that all are square. Re-tighten all the bolts, starting from the center outwards. For 16mm bolts torque to 252 nm. For 14 mm bolts torque to 162 nm.

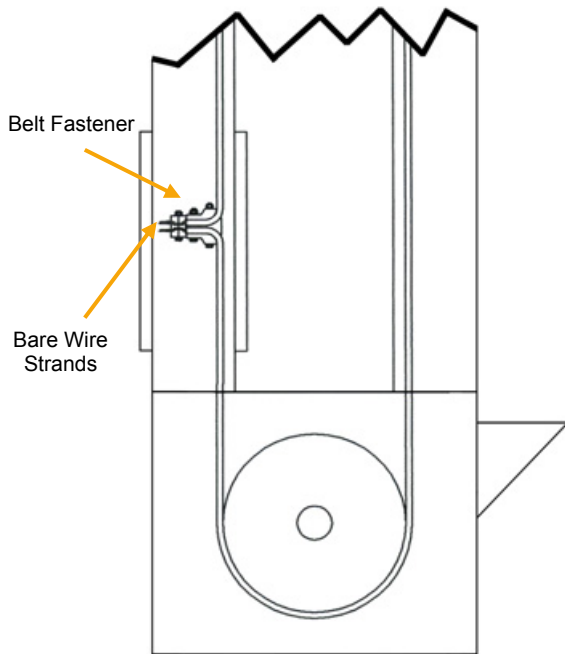
Cut off the spare loose ends of the belt about 50 mm from the belt fasteners. Make sure that they do not extend past the projection of the elevator buckets (**Figure I & J**).

Remove the tension on the chain blocks or turn buckles and remove the belt cross beams. Then apply tension to the belt by adjusting the belt take up device as fitted to the elevator.

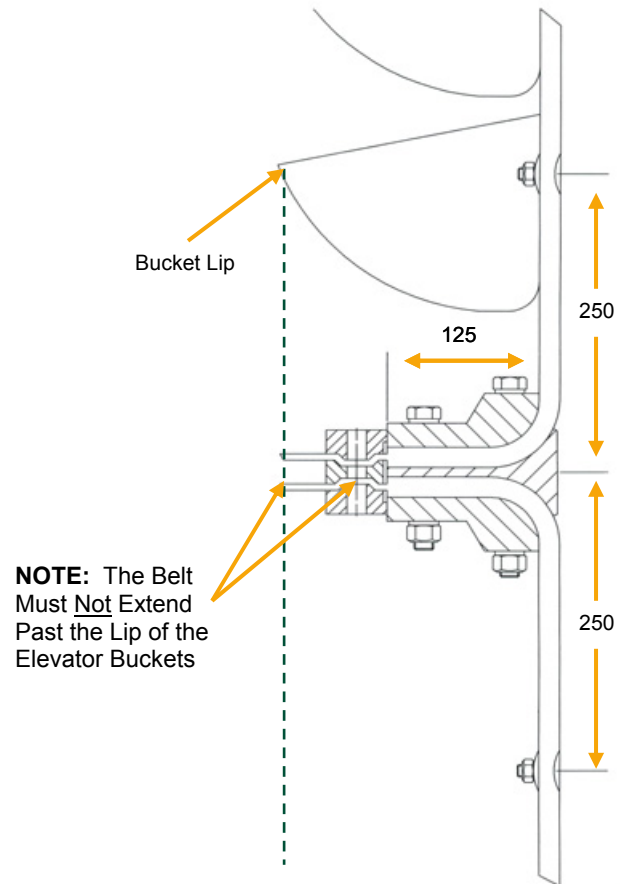
Run the belt round with the inching or pony slow drive, tracking and tension the belt accordingly.

Once the belt has been tensioned and tracked centrally, run the belt at full speed for 30 minutes. At the end of this period stop the belt and with the inching drive, position the belt fastener within the inspection doors. After locking out and tagging out the elevator and undertaking additional safety precautions, re-check the bolt tensions with a torque wrench starting from the center bolts and working alternatively towards the outside of the belt.

The belt fasteners should be checked every month to ensure the correct torque.



**Figure I**



**Figure J**

## INSTALLING THE BUCKETS

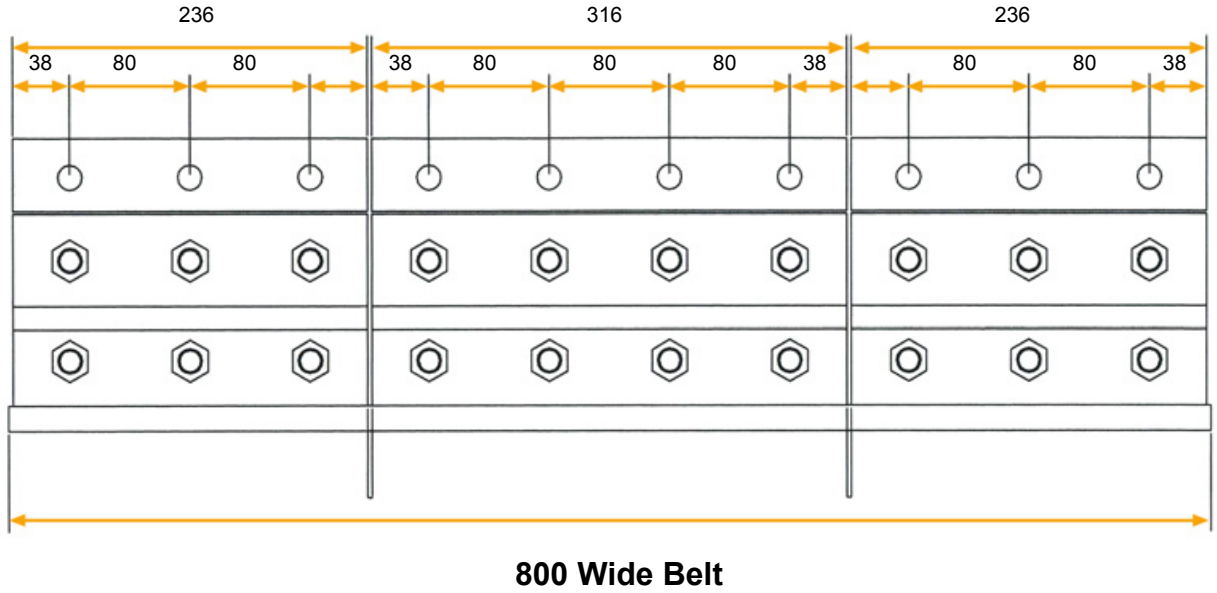
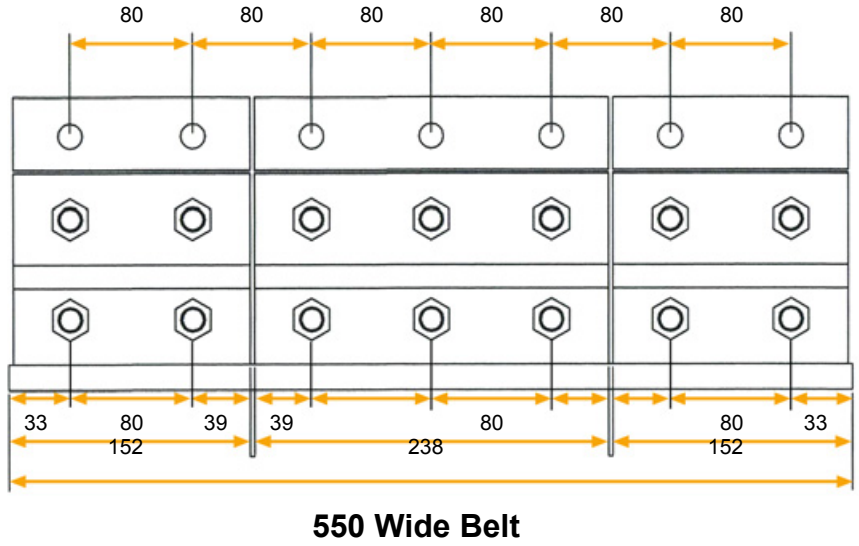
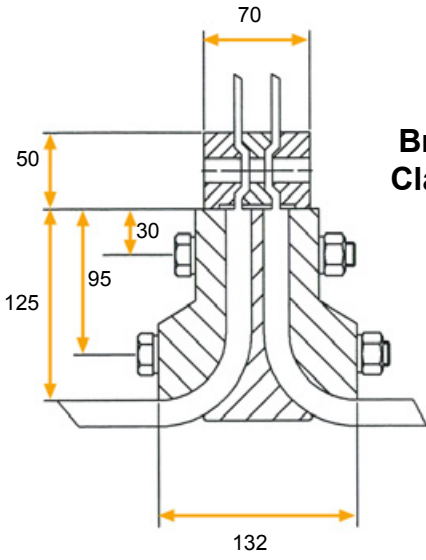
Install the buckets to the belt in sections, so as not to unbalance the whole assembly. Make sure to torque the bucket bolts to the required tension. When all the buckets are installed, operate the elevator on full load for about 12 hours, and then check that the belt is running centrally on the pulleys. Make sure to double check and re-tighten all the bucket bolts.

Check the bucket bolt torque once a month.

## MONITORING SYSTEM

The installation of a bucket elevator monitoring system is recommended. A system such as a Watchdog Elite will monitor for belt slippage, belt misalignment, hot bearings, head pulley misalignment and plugged chute conditions. The system should be installed to automatically shutdown the bucket elevator when a hazardous condition is detected.

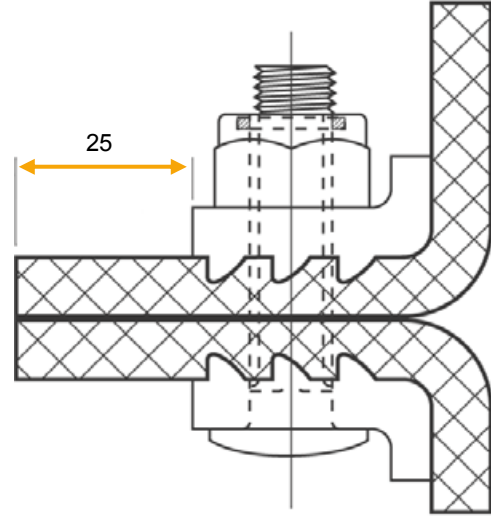
### APPENDIX – A 550 & 800 Wide Belts



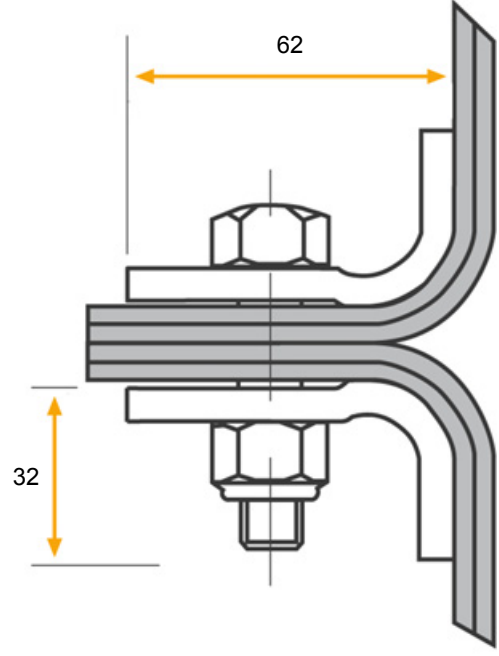
All measurements in millimeters

### APPENDIX – B Gripwell & Supergrip 1 Splices

Gripwell

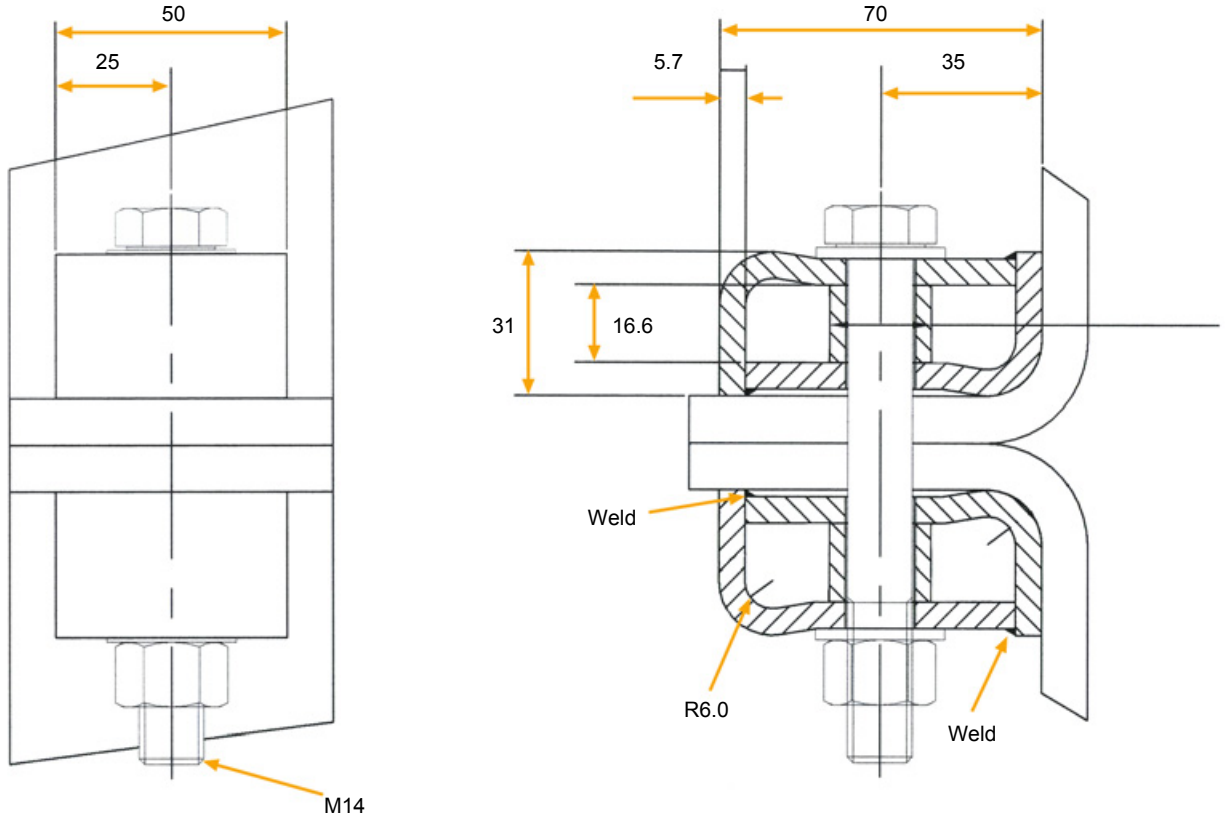


Supergrip 1



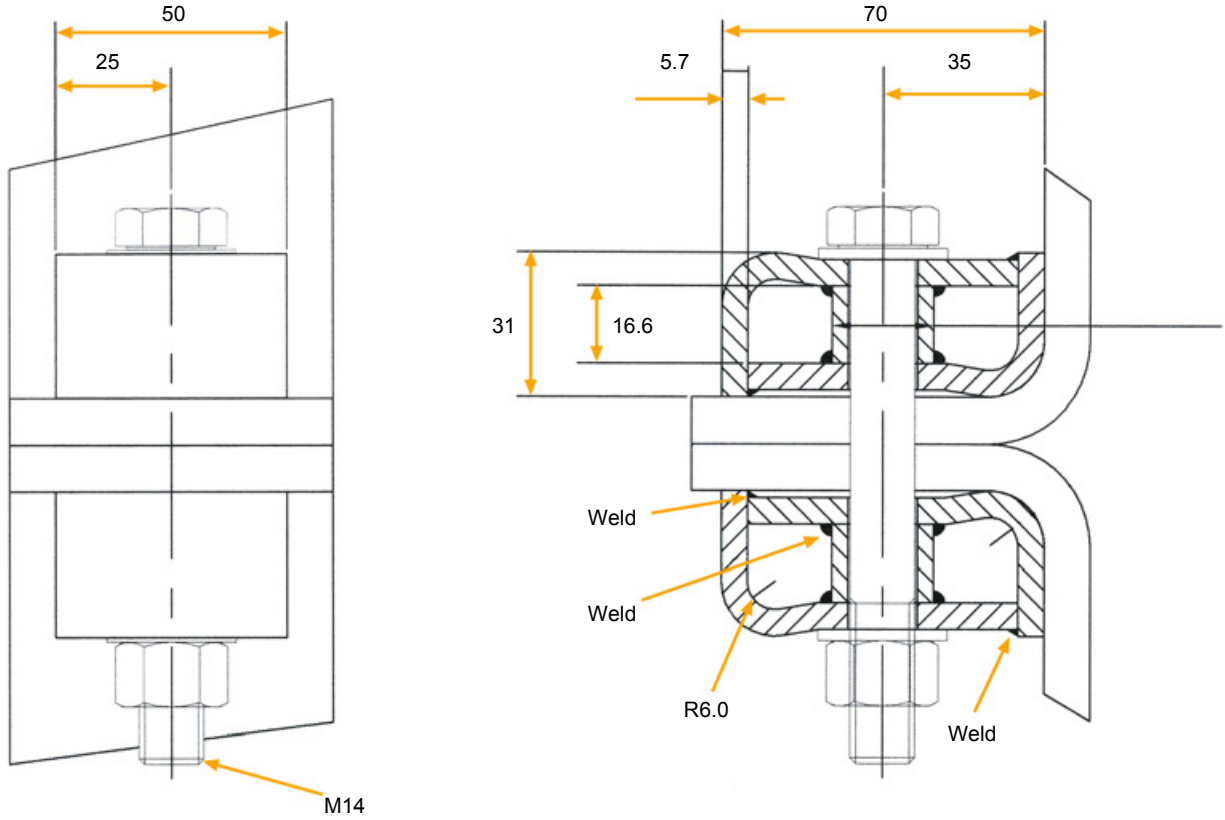
All measurements in millimeters

### APPENDIX – C Supergrip 2 Splice



All measurements in millimeters

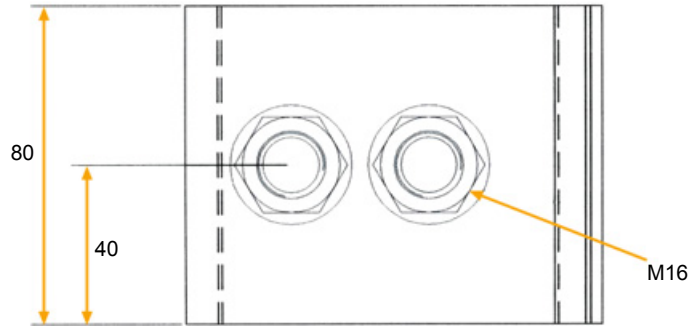
### APPENDIX – D Supergrip 3 Splice



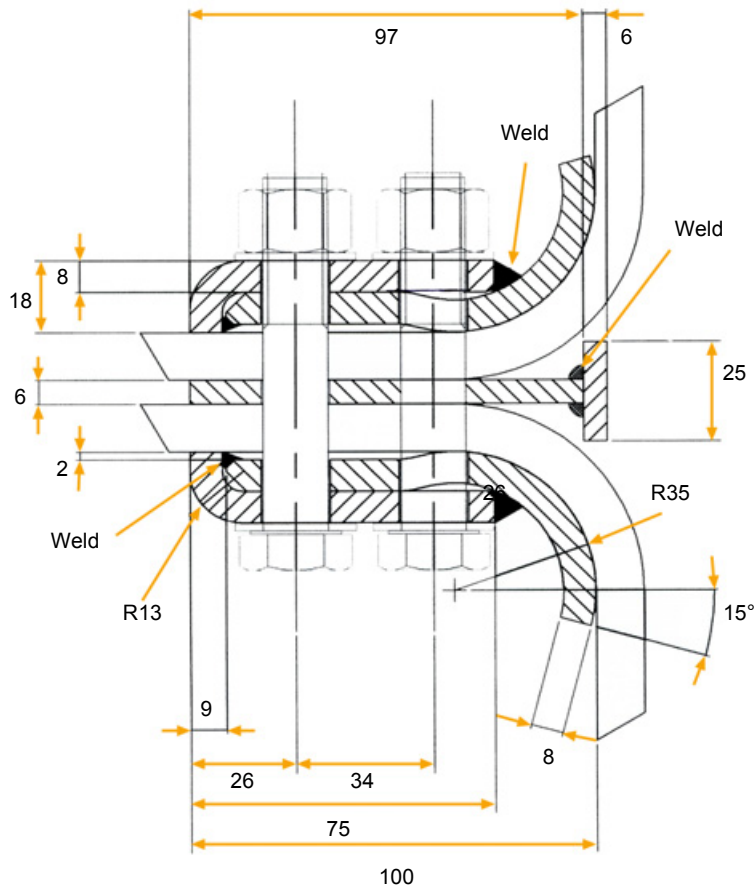
All measurements in millimeters

### APPENDIX – E Supergrip 4 Splice

Top View



Side View



All measurements in millimeters

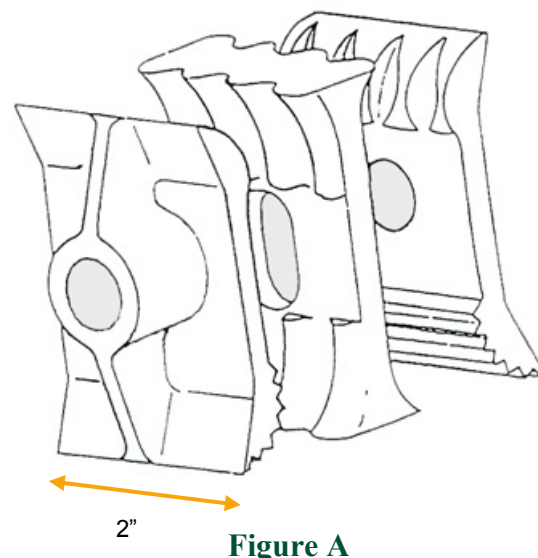


## APPENDIX – F

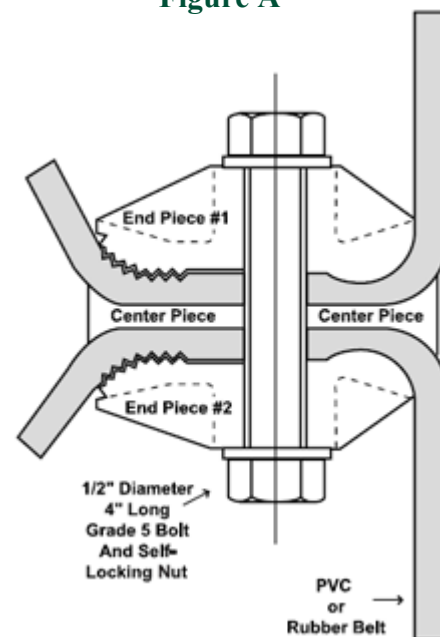
### INSTALLATION INSTRUCTIONS FOR 4B VISE SPLICE FASTENERS

**WARNING: DO NOT USE 4B VISE SPLICES ON MANLIFT BELTS!**

1. The splice consists of 3 parts, 2 identical end plates and 1 slotted center member. The slotted center member cannot be improperly installed as it is symmetrical on both sides. The three pieces fit together as shown in the illustration to the right (**Figure A**).
2. Particular care should be used in preparing your belting for the Splice. Both ends should be square, even and identically punched. After squaring the ends, draw a line approximately 2-1/4" from the end and use this as the center line of the holes to be punched. Using the Splice end plate as a template, mark the hole location for punching purposes, repeat as necessary across entire width of belt. With this accomplished, clamp the two ends together and utilize the pre-punched holes as a guide to the unpunched side. A drawing of a completed, proper assembly is illustrated to the right (**Figure B**). The "teeth" are at the tail!
3. **IMPORTANT:** A 1/2" diameter, 4" long Grade 5 bolt and self-locking nut are supplied as standard. 5" long bolts can be supplied for belts between 1/2" and 3/4" thickness. The bolt MUST BE TORQUED if proper functioning of the splice is expected. After a 30 minute run time, stop the leg belt and RE-TORQUE the bolts. Check the fastener every month to ensure correct bolt torque is maintained.
4. The torque requirements of the bolts, up to and including 600 PIW tension belt, is a minimum of 75 ft. lbs. Belts greater than 600 PIW tension require 100 ft. lbs.
5. Maximum strength can only be accomplished by using as many Splice sets across the belt width as possible. Each splice set will fasten 2" of belt width. A proper installation will begin within 1/4" of the belt edge, but never more than 3/4" from the belt edge. With proper installation, you will receive years of service with virtually no maintenance.



**Figure A**



**Figure B**