



# Vise Splice

ELEVATOR BELT SPLICE & FASTENER



**INSTALLATION INSTRUCTIONS**

# **OPERATION MANUAL**

Part No. 4BVS-AB



[www.go4b.com](http://www.go4b.com)



# TABLE OF CONTENTS

CUSTOMER SAFETY RESPONSIBILITIES	Page 4 - 5
PRODUCT OVERVIEW	Page 6
SPECIFICATIONS	Page 7
INSTALLATION	Page 7
ACCESSORIES	Page 9
PRODUCT WARRANTY	Page 11

 **DANGER**



**Exposed buckets and moving parts will cause severe injury or death.**

**Lockout power before removing cover or inspection door.**

Dear 4B Customer:

Congratulations on your purchase. 4B appreciates your business and is pleased you have chosen our products to meet your needs.

Please read in its entirety and understand the literature accompanying the product before you place the product into service. Please read the safety precautions carefully before operating the product. With each product you purchase from 4B, there are some basic but important safety considerations you must follow to be sure your purchase is permitted to perform its design function and operate properly and safely, giving you many years of reliable service. Please read and understand the Customer Safety Responsibilities listed below. Failure to follow this safety directive and the Operation Manuals and other material furnished or referenced, may result in serious injury or death.

### ***SAFETY NOTICE TO OUR CUSTOMERS***

- A. In order to maximize efficiency and safety, selecting the right equipment for each operation is vital. The proper installation of the equipment, and regular maintenance and inspection is equally important in continuing the proper operation and safety of the product. The proper installation and maintenance of all our products is the responsibility of the user unless you have asked 4B to perform these tasks.
- B. Periodic inspection by a qualified person will help assure your 4B product is performing properly. 4B recommends a documented inspection at least annually and more frequently under high use conditions.
- C. Please see the last page of this manual for all warranty information regarding this product.

### ***CUSTOMER SAFETY RESPONSIBILITIES***

#### **1. READ ALL LITERATURE PROVIDED WITH YOUR PRODUCT**

Please read all user, instruction and safety manuals to ensure that you understand your product operation and are able to safely and effectively use this product.

#### **2. YOU BEST UNDERSTAND YOUR NEEDS**

Every customer and operation is unique, and only you best know the specific needs and capabilities of your operation. Please contact 4B for assistance with any questions about the performance of products purchased from 4B. 4B is happy to discuss product performance with you at any time.

#### **3. SELECT A QUALIFIED AND COMPETENT INSTALLER**

Correct installation of the product is important for safety and performance. If you have not asked 4B to perform the installation of the unit on your behalf, it is critical for the safety of your operation and those who may perform work on your operation that you select a qualified and competent installer to undertake the installation. The product must be installed properly to perform its designed function.

The installer should be qualified, trained, and competent to perform the installation in accordance with all local and national codes, as well as any of your own standards and preventive maintenance requirements, and other product installation information supplied with the product. You should be prepared to provide the installer with all necessary installation information to assist in the installation.

#### **4. ESTABLISH AND FOLLOW A REGULAR MAINTENANCE AND INSPECTION SCHEDULE FOR YOUR 4B PRODUCTS**

You should develop a proper maintenance and inspection program to confirm that your system is in good working order at all times. You will be in the best position to determine the appropriate frequency for inspection. Many different factors known to the user will assist you in deciding the frequency of inspection. These factors may include but are not limited to weather conditions; construction work at the facility; hours of operation; animal or insect infestation; and the real-world experience of knowing how your employees perform their jobs. The personnel or person you select to install, operate, maintain, inspect or perform any work whatsoever, should be trained and qualified to perform these important functions. Complete and accurate records of the maintenance and inspection process should be created and retained by you at all times.

#### **5. RETAIN AND REFER TO THE OPERATION MANUAL FOR 4B'S SUGGESTED MAINTENANCE AND INSPECTION RECOMMENDATIONS**

As all operations are different, please understand that your specific operation may require additional adjustments in the maintenance and inspection process essential to permit the product to perform its intended function. Retain the Operation Manual and other important maintenance and service documents provided by 4B and have them readily available for people servicing your 4B product.

#### **6. SERVICE REQUEST**

If you have questions or comments about the operation of your 4B product or require service please contact the 4B location who supplied the product. Global 4B contact information can be found on the back of this manual or by visiting [www.go4b.com](http://www.go4b.com).



[www.go4b.com](http://www.go4b.com)



## WARNING

- Only use the high strength bolts and lock nuts supplied with the Vise Splice.
- Do not reuse bolts or lock nuts. If reinstalling splices, always use new hardware.
- Do not use the Vise Splice on manlift or steel cable belts.

## PRODUCT OVERVIEW

The 4B Vise Splice is a mechanical clamping device for use on most PVC and rubber elevator belts. Each splice is constructed from three segmented plates, two outside and one center.

Both outside plates have two different gripping areas. The belt end has a series of gripping teeth, while the pulley end has a ribbed gripping area (see image below). The center plate has a symmetrical rib design on both sides and cannot be improperly installed as it is not direction specific.

The gripping force of the Vise Splice is designed to use the tension of the belting. As the belt tension pulls on the outer plates, the pressure increases the gripping force of the teeth on the belt ends of the splice. The greater the belt tension, the more pressure is exerted on the gripping teeth, resulting in a vise like hold.

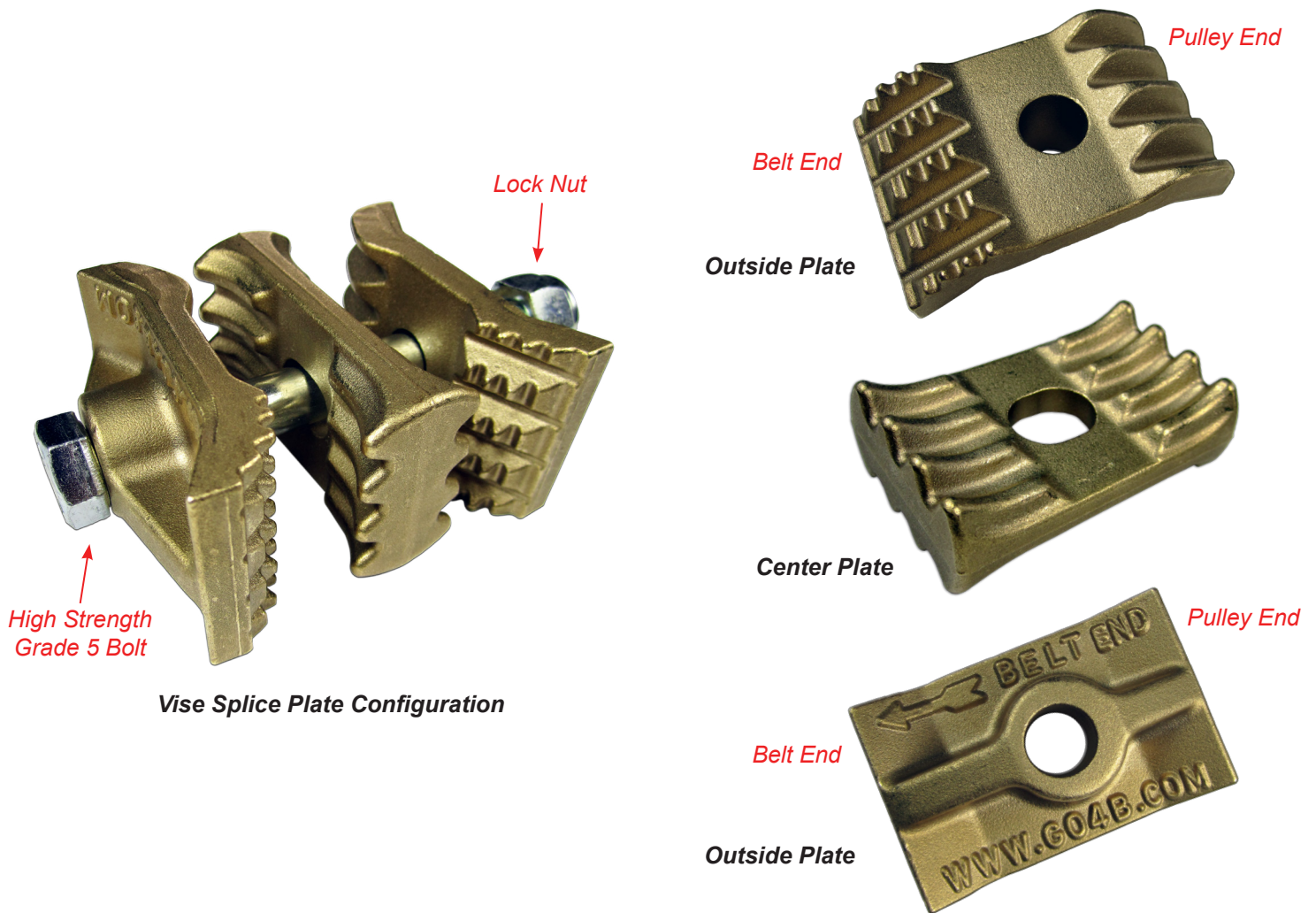

## NOTE

Outside plates have specific grip teeth designs, make sure that the belt end and the pulley end are installed correctly. The center plate has a uniform grip design and is not direction specific.



# SPECIFICATIONS

Construction -	Non-Ferrous Metal (Non-Sparking, Non-Corroding, Non-Rusting)
Tensile Strength -	Usable on Belts up to 800 PIW (1,400 N/mm)
Maximum Operating Temperature -	500° F (260° C)
Weight -	2.9 lbs (1.32 kg)
Belt Width -	Each Splice Accommodates 2" of Belt Width
Bolt Type -	Grade 5 - 9/16" Diameter
Bolt Lengths -	<ul style="list-style-type: none"> <li>- Use 4" Bolts for Belts up to 1/4" Thick</li> <li>- Use 4-1/2" Bolts for Belts between 1/4" and 1/2" Thick</li> <li>- Use 5" Bolts for Belts between 1/2" and 5/8" Thick</li> </ul>

# INSTALLATION

1. Secure the belting to safely install the splice. Both ends of the belt should be square and even. Use the supplied punch template tape to ensure that the belt is punched correctly. Apply the tape squarely on one of the belt ends and proceed to step 3. If you are not using the temple tape, go to step 2.
2. After squaring the ends, draw a center line approximately 4-1/4" from the end of the belt along the entire belt width. Odd belt widths require the splice to be installed 1/2" from the edge of the belt, even belt widths will begin just inside the belt edge. Use the outside plate of the Vise Splice as a template to mark the punch holes along the center line. After marking the first hole, move over 2" and mark the next hole. Continue this process until all holes are marked. Each splice will accommodate 2" of belt width.
3. Punch the required holes on one belt end by using a 9/16" belt punch tool (sold separately). Clamp the two belt ends together, making sure they are square and even. Use the punched side as a template to make the holes on the other end of the belt.
4. The illustration to the right represents a properly assembled Vise Splice on a belt. Make sure that the marked belt ends of the splice are aligned correctly to the belt, as indicted by the arrows on both outside plates. The grip teeth always face the belt. The center plate has a symmetrical rib design on both sides and cannot be improperly installed as it is not direction specific.
5. Use the bolts and lock nuts supplied with the Vise Splice to insure proper tensile strength. For belting up to 600 PIW, torque bolts to 75 ft. lbs. For belts greater than 600 PIW, torque bolts to 100 ft. lbs.
6. Once installation is complete, run the belt at normal speed for at least 30 minutes. After the elapsed time, stop the belt and re-torque the bolts to ensure proper splice grip.
7. Be sure to follow proper maintenance procedures by inspecting the entire installation on a monthly basis. Vise Splice bolt torque must be maintained to ensure proper belt grip.
8. If reinstalling the Vise Splice, always use new hardware (bolts and lock nuts).
9. For any Vise Splice installation questions, contact 4B.

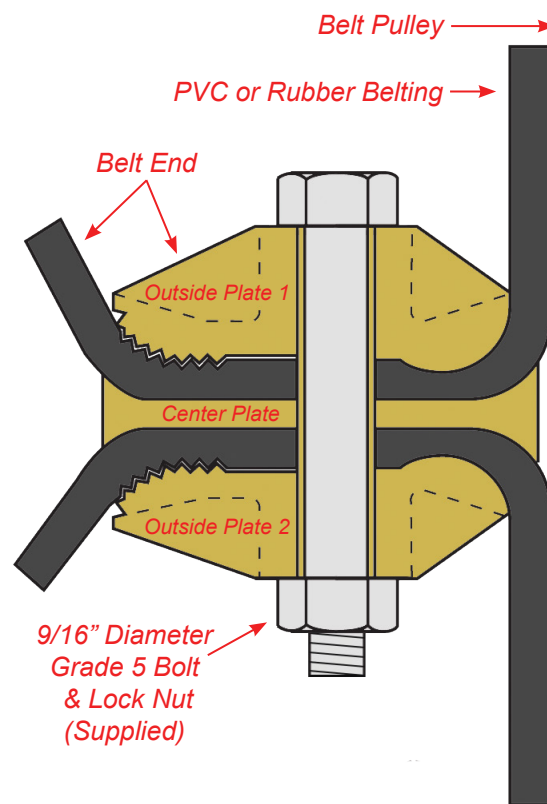

# INSTALLATION IMAGES

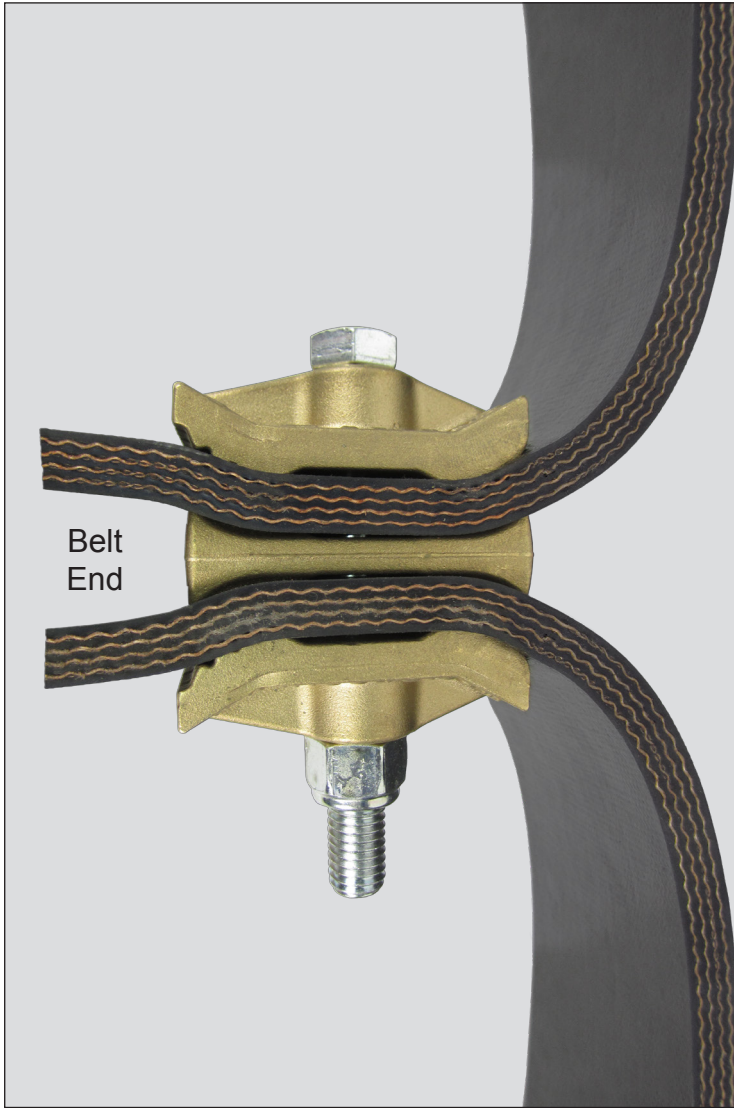

Side View of  
Vise Splice Installation



Top View of  
Vise Splice Installation

Belt End



# ACCESSORIES

**4BVS-TT**  
Punch Template Tape  
(Supplied with Splice)

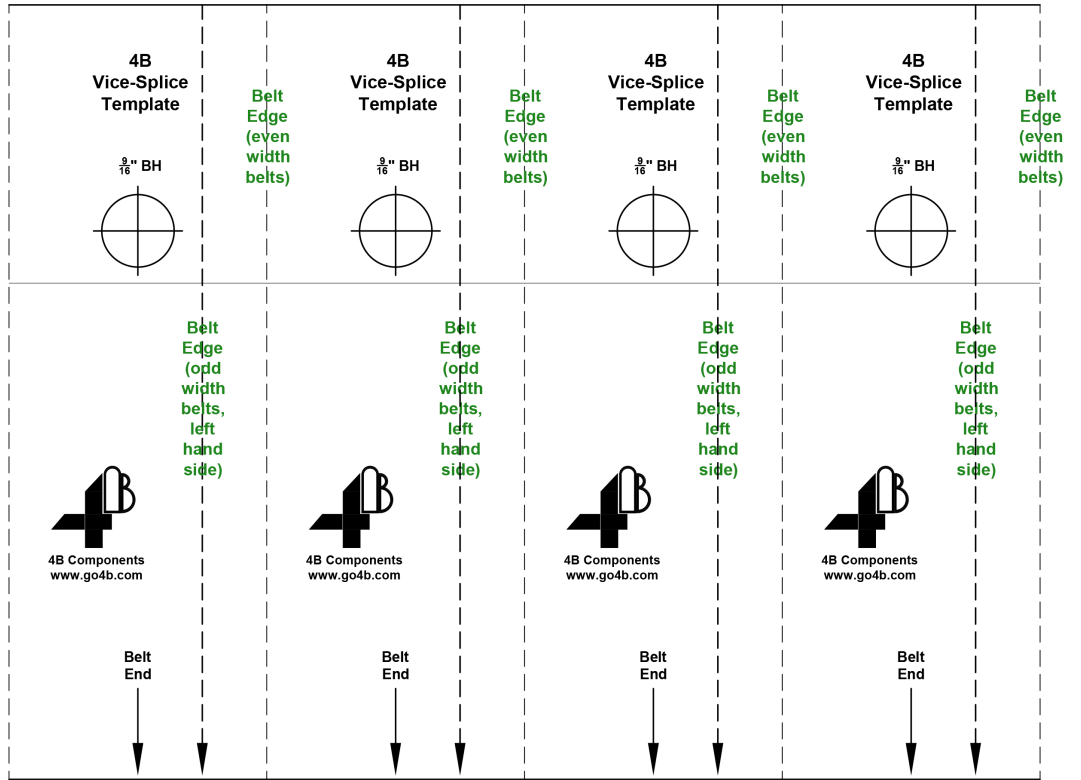

**MBGT-9**  
Belt Punch Tool  
(Sold Separately)

- Made from heat treated carbon steel.
- Easily cuts 9/16" diameter holes.
- Can be used with a drill, impact wrench or mallet.

	 <b>WARNING</b>
	<p><b>Always wear eye protection to avoid injury from flying debris.</b></p> <p><b>Failure to do so can result in serious personal injury.</b></p>



# PRODUCT WARRANTY

## 1. EXCLUSIVE WRITTEN LIMITED WARRANTY

ALL PRODUCTS SOLD ARE WARRANTED BY THE COMPANY 4B COMPONENTS LIMITED AND 4B BRAIME COMPONENTS LIMITED HEREIN AFTER REFERRED TO AS 4B TO THE ORIGINAL PURCHASER AGAINST DEFECTS IN WORKMANSHIP OR MATERIALS UNDER NORMAL USE FOR ONE (1) YEAR AFTER DATE OF PURCHASE FROM 4B. ANY PRODUCT DETERMINED BY 4B AT ITS SOLE DISCRETION TO BE DEFECTIVE IN MATERIAL OR WORKMANSHIP AND RETURNED TO A 4B BRANCH OR AUTHORIZED SERVICE LOCATION, AS 4B DESIGNATES, SHIPPING COSTS PREPAID, WILL BE, AS THE EXCLUSIVE REMEDY, REPAIRED OR REPLACED AT 4B'S OPTION.

## 2. DISCLAIMER OF IMPLIED WARRANTY

NO WARRANTY OR AFFIRMATION OF FACT, EXPRESSED OR IMPLIED, OTHER THAN AS SET FORTH IN THE EXCLUSIVE WRITTEN LIMITED WARRANTY STATEMENT ABOVE IS MADE OR AUTHORIZED BY 4B. 4B SPECIFICALLY DISCLAIMS ANY LIABILITY FOR PRODUCT DEFECT CLAIMS THAT ARE DUE TO PRODUCT MISUSE, ABUSE OR MISAPPLICATIONS, AS AUTHORIZED BY LAW, 4B SPECIFICALLY DISCLAIMS ALL WARRANTIES THAT THE PRODUCT IS FIT OR MERCHANTABLE FOR A PARTICULAR PURPOSE.

## 3. NO WARRANTY "BY SAMPLE OR EXAMPLE"

ALTHOUGH 4B HAS USED REASONABLE EFFORTS TO ACCURATELY ILLUSTRATE AND DESCRIBE THE PRODUCTS IN ITS CATALOGS, LITERATURE, AND WEBSITES, SUCH ILLUSTRATIONS AND DESCRIPTIONS ARE FOR THE SOLE PURPOSE OF PRODUCT IDENTIFICATION AND DO NOT EXPRESS OR IMPLY A WARRANTY AFFIRMATION OF FACT, OF ANY KIND OR A WARRANTY OR AFFIRMATION OF FACT THAT THE PRODUCTS WILL CONFORM TO THEIR RESPECTIVE ILLUSTRATIONS OR DESCRIPTIONS. 4B EXPRESSLY DISCLAIMS ANY WARRANTY OR AFFIRMATION OF FACT, EXPRESSED OR IMPLIED, OTHER THAN AS SET FORTH IN THE EXCLUSIVE WRITTEN LIMITED WARRANTY STATEMENT ABOVE, INCLUDING, WITHOUT LIMITATION, THE IMPLIED WARRANTIES OF MERCHANTABILITY AND FITNESS FOR A PARTICULAR PURPOSE.

## 4. LIMITATION OF DAMAGES

ANY LIABILITY FOR CONSEQUENTIAL, INCIDENTAL, SPECIAL, EXEMPLARY, OR PUNITIVE DAMAGES, OR FOR LOSS OF PROFIT WHETHER DIRECT OR INDIRECT, IS EXPRESSLY DISCLAIMED.

With subsidiaries in North America, Europe, Asia, Africa and Australia along with a worldwide network of distributors, 4B can provide practical solutions for all your applications no matter the location.



**4B BRAIME COMPONENTS LTD.**

Hunslet Road  
Leeds  
LS10 1JZ  
United Kingdom  
Tel: +44 (0) 113 246 1800  
Fax: +44 (0) 113 243 5021

**4B DEUTSCHLAND**

9 Route de Corbie  
Lamotte Warfusée  
F-80800  
France  
Tel: +49 (0) 700 2242 4091  
Fax: +49 (0) 700 2242 3733

**4B ASIA PACIFIC**

Build No. 899/1 Moo 20  
Soi Chongsiri, Bangplee-Tam Ru Road,  
Tanbon Bangpleeyai, Amphur Bangplee,  
Samutprakarn 10540  
Thailand  
Tel: +66 (0) 2 173-4339  
Fax: +66 (0) 2 173-4338

**4B COMPONENTS LTD.**

625 Erie Avenue  
Morton, IL 61550  
USA  
Tel: 309-698-5611  
Fax: 309-698-5615

**4B FRANCE**

9 Route de Corbie  
80800 Lamotte Warfusée  
France  
Tel: +33 (0) 3 22 42 32 26  
Fax: +33 (0) 3 22 42 37 33

**4B AFRICA**

14 Newport Business Park  
Mica Drive, Kya Sand  
2163 Johannesburg  
South Africa  
Tel: +27 (0) 11 708 6114  
Fax: +27 (0) 11 708 1654

**4B AUSTRALIA**

Unit 1/18 Overlord Place  
Acacia Ridge  
Queensland 4110  
Australia  
Tel: +61 (0) 7 3711 2565  
Fax: +61 (0) 7 3711 2574

[www.go4b.com](http://www.go4b.com)