



M100 Stopswitch

STOPPED MOTION MONITOR



INSTALLATION INSTRUCTIONS



OPERATION MANUAL

Part No.'s - M1003V10AI

www.go4b.com

TABLE OF CONTENTS

| | |
|----------------------------------|-------------|
| CUSTOMER SAFETY RESPONSIBILITIES | Page 3 - 4 |
| PRODUCT OVERVIEW | Page 5 |
| SPECIFICATIONS | Page 5 |
| APPROVALS | Page 6 |
| DIMENSIONS | Page 7 |
| INSTALLATION | Page 7 - 8 |
| STANDARD WIRING DIAGRAM | Page 8 - 9 |
| TESTING & COMMISSIONING | Page 9 - 10 |
| TROUBLESHOOTING GUIDE | Page 10 |
| PRODUCT WARRANTY | Page 11 |

| | |
|--|---|
|   |  WARNING |
| | <p>Rotating parts can crush, cut and entangle.</p> <p>Do NOT operate with guard removed.</p> <p>Lockout power before removing guard or servicing.</p> |

Dear 4B Customer:

Congratulations on your purchase. 4B appreciates your business and is pleased you have chosen our products to meet your needs.

Please read in its entirety and understand the literature accompanying the product before you place the product into service. Please read the safety precautions carefully before operating the product. With each product you purchase from 4B, there are some basic but important safety considerations you must follow to be sure your purchase is permitted to perform its design function and operate properly and safely, giving you many years of reliable service. Please read and understand the Customer Safety Responsibilities listed below. Failure to follow this safety directive and the Operation Manuals and other material furnished or referenced, may result in serious injury or death.

SAFETY NOTICE TO OUR CUSTOMERS

- A. In order to maximize efficiency and safety, selecting the right equipment for each operation is vital. The proper installation of the equipment, and regular maintenance and inspection is equally important in continuing the proper operation and safety of the product. The proper installation and maintenance of all our products is the responsibility of the user unless you have asked 4B to perform these tasks.
- B. All installation and wiring must be in accordance with Local and National Electrical Codes and other standards applicable to your industry. The installation of the wiring should be undertaken by an experienced and qualified professional electrician. Failure to correctly wire any product and/or machinery can result in the product or machine failing to operate as intended, and can defeat its design function.
- C. Periodic inspection by a qualified person will help assure your 4B product is performing properly. 4B recommends a documented inspection at least annually and more frequently under high use conditions.
- D. Please see the last page of this manual for all warranty information regarding this product.

CUSTOMER SAFETY RESPONSIBILITIES

1. READ ALL LITERATURE PROVIDED WITH YOUR PRODUCT

Please read all user, instruction and safety manuals to ensure that you understand your product operation and are able to safely and effectively use this product.

2. YOU BEST UNDERSTAND YOUR NEEDS

Every customer and operation is unique, and only you best know the specific needs and capabilities of your operation. Please go to www.go4b.com or call the 24-hour hotline at +1-309-698-5611 for assistance with any questions about the performance of products purchased from 4B. 4B is happy to discuss product performance with you at any time.

3. SELECT A QUALIFIED AND COMPETENT INSTALLER

Correct installation of the product is important for safety and performance. If you have not asked 4B to perform the installation of the unit on your behalf, it is critical for the safety of your operation and those who may perform work on your operation that you select a qualified and competent electrical installer to undertake the installation. The product must be installed properly to perform its designed functions. The installer should be qualified, trained, and competent to perform the installation in accordance with local and national electrical codes, all relevant regulations, as well as any of your own standards and preventive maintenance requirements, and other product installation information supplied with the product. You should be prepared to provide the installer with all necessary installation information to assist in the installation.

4. ESTABLISH AND FOLLOW A REGULAR MAINTENANCE AND INSPECTION SCHEDULE FOR YOUR 4B PRODUCTS

You should develop a proper maintenance and inspection program to confirm that your system is in good working order at all times. You will be in the best position to determine the appropriate frequency for inspection. Many different factors known to the user will assist you in deciding the frequency of inspection. These factors may include but are not limited to weather conditions; construction work at the facility; hours of operation; animal or insect infestation; and the real-world experience of knowing how your employees perform their jobs. The personnel or person you select to install, operate, maintain, inspect or perform any work whatsoever, should be trained and qualified to perform these important functions. Complete and accurate records of the maintenance and inspection process should be created and retained by you at all times.

5. RETAIN AND REFER TO THE OPERATION MANUAL FOR 4B'S SUGGESTED MAINTENANCE AND INSPECTION RECOMMENDATIONS

As all operations are different, please understand that your specific operation may require additional adjustments in the maintenance and inspection process essential to permit the monitoring device to perform its intended function. Retain the Operation Manual and other important maintenance and service documents provided by 4B and have them readily available for people servicing your 4B equipment. Should you have any questions, please call go to www.go4b.com or call the 24-hour hotline at +1-309-698-5611.

6. SERVICE REQUEST

If you have questions or comments about the operation of your unit or require the unit to be serviced please contact the 4B location who supplied the product or send your request go to www.go4b.com or call the 24-hour hotline at +1-309-698-5611. Please have available product part numbers, serial numbers, and approximate date of installation. In order to assist you, after the product has been placed into service, complete the online product registration section which is accessed via our website www.go4b.com.

WARNING

- Rotating machinery can cause serious injury or death
- Always lockout and tagout the machine prior to installation

PRODUCT OVERVIEW

The M100 Stopswitch is a simple inductive proximity shaft speed monitoring device. The self-contained unit has a single set point, which signals when the shaft has stopped rotating. It can be used for process control, motion detection and stopped shaft indication.

An inductive sensing device located in the nose of the M100 enclosure will detect a metal target. Ideally, the target should be a ferrous metal, but non-ferrous metal will be detected at a shorter range. Maximum range for ferrous targets is 6 mm (15/64 in.) and for non-ferrous targets it is 5 mm (13/64 in.), assuming a 19 mm (3/4 in.) diameter target. Smaller targets may be used but operating distances will be reduced.

The M100 Stopswitch requires no calibration and provides an output when the shaft has stopped rotating. The unit incorporates a start-up delay of 4 seconds to allow moving parts to achieve correct speed, thereafter, if a pulse is not received within 4 seconds an output stopped motion signal is indicated.

SPECIFICATIONS

| | |
|----------------------|--|
| Supply Voltage: | 24 to 240 VAC/VDC |
| Supply Fusing: | Supply to be fused at 500mA maximum. Note: fuse must be 1500A capable. 1 fuse per sensor MUST be used. |
| Switching Capacity: | 50 mA maximum |
| Saturation Voltage: | 5.5 Volts maximum (output on) |
| Leakage Current: | 1 mA maximum (output off) |
| Ambient Temperature: | 5°F (-15°C) to +122°F (+50°C) |
| Output State: | FET Contact closed above 0% set speed Contact opens when zero speed detected |
| Sensing Range: | 6 mm (15/64") maximum on ferrous metal at 77°F (25°C) 5 mm (13/64") maximum on non-ferrous metal at 77°F (25°C) |
| Input Pulse Range: | From 20 to 3,600 pulses per minute (PPM) |
| Start-Up Delay: | 4 seconds |
| Trip Point: | When no pulse is detected for more than 4s (zero speed condition) |
| Enclosure: | GRILON POLYAMIDE - ISO threaded 18 mm by 1.0 mm pitch |
| Relative Humidity: | 90% RH |
| LED Indicators: | Blue - Target Sensed, Green - Speed Present |
| Connections: | 2 wire; 3m long cable. |
| Protection: | IP66 |

APPROVALS

| | |
|-------|---|
| ATEX | Baseefa14ATEX0115X ⊕ II 2G Ex mb IIC T5 Gb ⊕ II 2D Ex mb IIIC t100 C Db Tamb - 15 C to +50 C ⊕ I M2 Ex mb I Mb |
| IECEX | IECEXBAS14.0061X Ex mb IIC T5 Gb Ex mb IIIC t100 C Db I M2 Ex mb I Mb Tamb - 15 C to +50 C |

DIMENSIONS

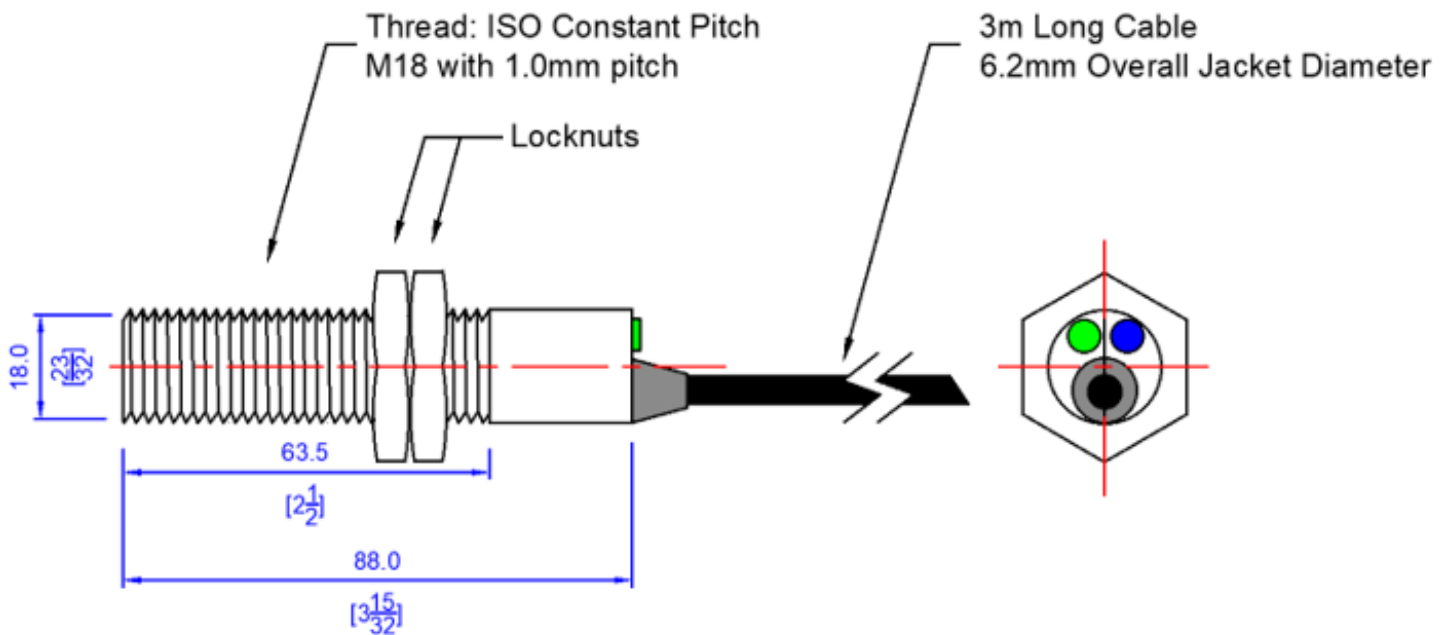

INSTALLATION

The M100 Stopswitch should be wired as indicated by the connection diagram.

The M100 Stopswitch must be wired through a load/resistor (see standard wiring diagram) and not directly to supply voltage. The supply polarity is not important and the load can be connected in either wire.



Do not wire the M100 Stopswitch to a motor starting coil.

It is not recommended to wire the M100 Stopswitch in series with other sensors.

The cable on the M100 Stopswitch can be extended to virtually any length in ordinary 2 wire cable.

Two locknuts are provided to mount the M100 Stopswitch in position. Mount securely to withstand vibration.

Ensure that the unit and target are adequately guarded (refer to page 8).

| | |
|---|--|
|  | ! WARNING |
|  | Rotating parts can crush, cut and entangle. Do NOT operate with guard removed. Lockout power before removing guard or servicing. |

⚠ WARNING

O.S.H.A. requires that all exposed rotating shafts are provided with a full guard. Therefore, this device and its target must be equipped with a guard.

Fasten the M100 to a suitable mounting bracket, such as 4B's Whirligig® universal shaft sensor mount, with the nose of the switch within the sensing range of the target, as shown below -



STANDARD WIRING DIAGRAM

All wiring must be in accordance with local and national electrical codes and should be undertaken by an experienced and qualified electrician.

Use dust/liquid tight flexible metal conduit (when appropriate) with approved fittings to protect the sensor cables. Use rigid metal conduit to protect the cables from the sensors to the control unit. Conduit systems can channel water due to ingress and condensation directly to sensors and sensor connections which over time will adversely affect the performance of the system. As such, the installation of low point conduit drains is recommended for all sensors.

The M100 has a two wire cable. It must be wired through a load (see below) with the same voltage rating as the supply being used. The supply polarity to the M100 is not important and the load can be connected to either wire. The cable can be extended to virtually any length with ordinary 2 wire cable.

Do not wire the M100 directly to a motor starting coil due to the 50 mA maximum current capacity.

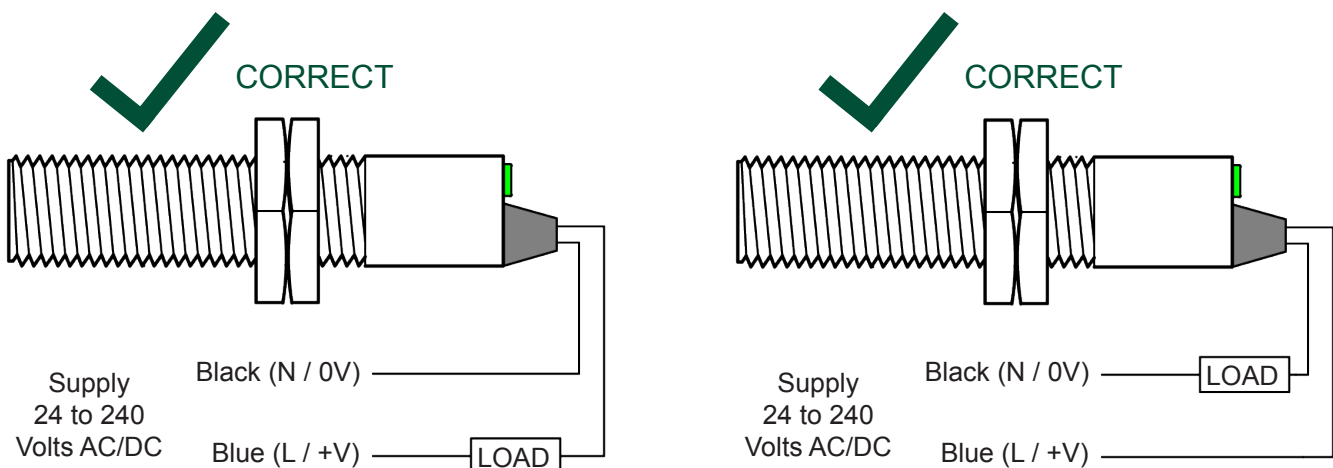

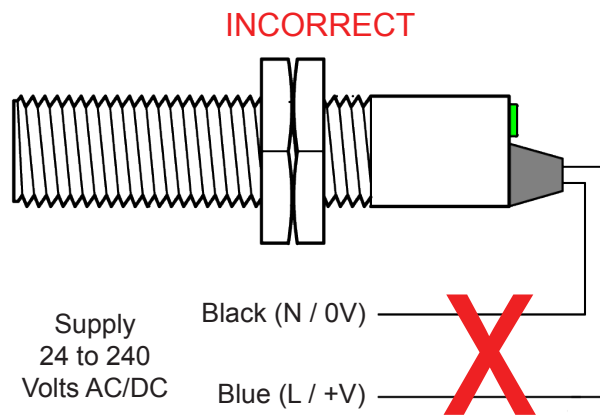

NOTE

Load refers to any item that limits current (PLC input, ice cube relay, etc.) that you would like the M100 to switch on/off. Load must be the same voltage rating as the supply being used. Total circuit current is 50 mA (max).

TYPICAL CONTROL WIRING

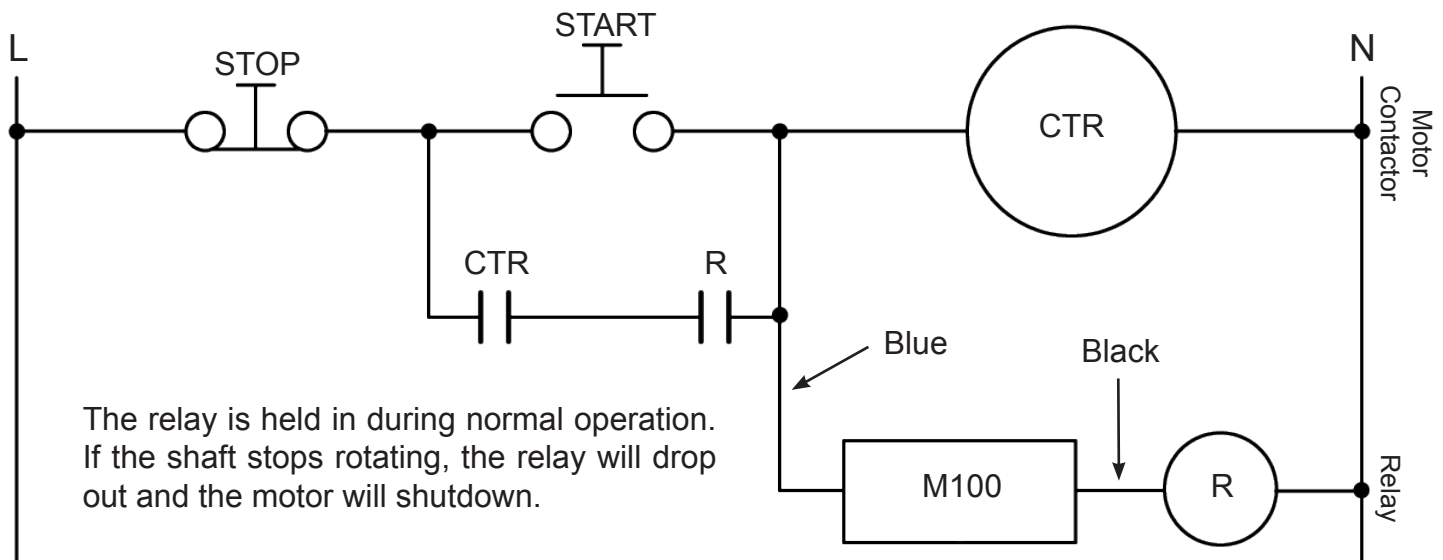

TESTING AND COMMISSIONING

1. Check that the unit is correctly installed (see standard wiring diagram).
2. Check that the distance between the target, stud or bolt head and sensing face of M100 Stopswitch is within the minimum distance specified.
3. Start up machine.
4. The unit is now set. If the M100 Stopswitch fails to receive a signal within every 4 second period, (i.e. target stops rotating or there is a power failure) the unit will switch to normally open.
5. Test by sliding a metal putty knife between the sensor and the target.
6. During normal operation the blue LED will flash each time an input signal is received. The closed circuit is indicated by a permanent green LED. If the unit fails to receive a signal for 4 seconds the circuit reverts to open state indicated by the green LED going out.

⚠ WARNING

If the system does not immediately shutdown as expected or alarm as required, then remove the machine from service until the problem has been diagnosed and corrected.

TROUBLESHOOTING GUIDE

| FAULT | REMEDY |
|---------------------------------------|---|
| Blue LED (input) does not illuminate | Check that the load and the supply voltage are the same, and that the total circuit current is less than 50mA. Slide a screwdriver blade across the face of the sensor, the input LED should flicker. If not, contact 4B. If the input LED does flicker, move the front face of the sensor closer to the target and check the target size as specified under "INSTALLATION". |
| Blue LED (input) Stays on Permanently | Either increase the gap between the target and the shaft, or between the target and the sensor face. |

PARTS & ACCESSORIES



CDL1 & CDL4 Load Devices

The CDL1 and CDL4 devices add additional loads to PLC inputs. The CDL1 is for 110 VAC powered inputs, while the CDL4 (not pictured) is designed for 24 VDC (NPN and PNP type) low power inputs. Both devices can be used with the M100 Stopswitch.

Notte: This unit is only necessary if the PLC input can detect 1mA of current as a logic High. Please check the PLC input card technical literature for this value.

PRODUCT WARRANTY

Dear 4B Customer:

Congratulations on your purchase. 4B appreciates your business and is pleased you have chosen our products to meet your needs.

Please read in its entirety and understand the literature accompanying the product before you place the product into service. Please read the safety precautions carefully before operating the product. With each product you purchase from 4B, there are some basic but important safety considerations you must follow to be sure your purchase is permitted to perform its design function and operate properly and safely, giving you many years of reliable service. Please read and understand the Customer Safety Responsibilities listed below. Failure to follow this safety directive and the Operation Manuals and other material furnished or referenced, may result in serious injury or death.

SAFETY NOTICE TO OUR CUSTOMERS

- A. In order to maximize efficiency and safety, selecting the right equipment for each operation is vital. The proper installation of the equipment, and regular maintenance and inspection is equally important in continuing the proper operation and safety of the product. The proper installation and maintenance of all our products is the responsibility of the user unless you have asked 4B to perform these tasks.
- B. All installation and wiring must be in accordance with Local and National Electrical Codes and other standards applicable to your industry. The installation of the wiring should be undertaken by an experienced and qualified professional electrician. Failure to correctly wire any product and/or machinery can result in the product or machine failing to operate as intended, and can defeat its design function.
- C. Periodic inspection by a qualified person will help assure your 4B product is performing properly. 4B recommends a documented inspection at least annually and more frequently under high use conditions.
- D. Please see the last page of this manual for all warranty information regarding this product.

CUSTOMER SAFETY RESPONSIBILITIES

1. READ ALL LITERATURE PROVIDED WITH YOUR PRODUCT

Please read all user, instruction and safety manuals to ensure that you understand your product operation and are able to safely and effectively use this product.

2. YOU BEST UNDERSTAND YOUR NEEDS

Every customer and operation is unique, and only you best know the specific needs and capabilities of your operation. Please go to www.go4b.com or call the 24-hour hotline at +1-309-698-5611 for assistance with any questions about the performance of products purchased from 4B. 4B is happy to discuss product performance with you at any time.

With subsidiaries in North America, Europe, Asia, Africa and Australia along with a worldwide network of distributors, 4B can provide practical solutions for all your applications no matter the location.



**4B BRAIME
COMPONENTS LTD.**

Hunslet Road
Leeds
LS10 1JZ
United Kingdom
Tel: +44 (0) 113 246 1800
Fax: +44 (0) 113 243 5021

4B DEUTSCHLAND

9 Route de Corbie
80800 Lamotte Warfusée
France
Tel: +49 (0) 700 2242 4091
Fax: +49 (0) 700 2242 3733

4B ASIA PACIFIC

Build No. 899/1 Moo 20
Soi Chongsiri, Bangplee-Tam
Ru Road, Tanbon Bangpleeyai,
Amphur Bangplee,
Samutprakarn 10540
Thailand
Tel: +66 (0) 2 173-4339
Fax: +66 (0) 2 173-4338

4B COMPONENTS LTD.

625 Erie Avenue
Morton, IL 61550
USA
Tel: 309-698-5611
Fax: 309-698-5615

4B FRANCE

9 Route de Corbie
80800 Lamotte Warfusée
France
Tel: +33 (0) 3 22 42 32 26
Fax: +33 (0) 3 22 42 37 33

4B AFRICA

14 Newport Business Park
Mica Drive, Kya Sand
2163 Johannesburg
South Africa
Tel: +27 (0) 11 708 6114
Fax: +27 (0) 11 708 1654

4B AUSTRALIA

Building 1, 41 Bellrick Street
Acacia Ridge
Queensland 4110
Australia
Tel: +61 (0)7 3216 9365
Fax: +61 (0)7 3219 5837

www.go4b.com